The Trouble With Fusion

Long touted as an inexhaustible energy source for the next century, fusion as it is now being developed will almost certainly be too expensive and unreliable for commercial use.

By Lawrence M. Lidsky

The technically advanced nations of the world will spend over \$1 billion this year in the quest for controlled thermonuclear fusion power. This program has been sustained for 30 years with steadily mounting commitments of money and the dedication of an international group of scientists and engineers. Our knowledge of the related physics has grown enormously in the effort. Now the solution of the scientific problem appears to be almost within our grasp, and many assume that with it will come that technological Holy Grail: virtually unlimited, environmentally safe energy. But that outcome is unlikely. Instead, the costly fusion reactor is in danger of joining the ranks of other technical “triumphs” such as the zeppelin, the supersonic transport, and the fission breeder reactor that turned out to be unwanted and unused.

“Long touted as an inexhaustible energy source for the next century, fusion as it is now being developed will almost certainly be too expensive and unreliable for commercial use.”

The dominating goal of the fusion program is to produce a reactor fueled by deuterium and tritium, isotopes of hydrogen containing one and two extra neutrons. This choice of fuel greatly eases the problem of achieving an energy-producing fusion reaction, but the choice also has features that make it far more difficult to turn that energy source into a useful power plant. The most serious difficulty concerns the very high energy neutrons released in the deuterium-tritium (D-T) reaction. These

uncharged nuclear particles damage the reactor structure and make it radioactive. A chain of undesirable effects ensures that any reactor employing D-T fusion will be a large, complex, expensive, and unreliable source of power. That is hardly preferable to present-day fission reactors, much less the improved fission reactors that are almost sure to come.

When these drawbacks become more widely realized, disillusionment with the existing fusion program will weaken the prospects for other fusion programs, no matter how wisely redirected, for decades to come. But such a result isn't necessary. The public has shown that it is enlightened enough to support long-range scientific research without a clearly defined near-term goal; witness the support for expensive research on high-energy physics. Furthermore, other nuclear reactions such as the fusion of protons with lithium or boron produce either fewer neutrons or none at all. A reactor based on these fuels would be far preferable to existing fission reactors.

Of course, we do not know how to build a reactor to ignite such “advanced” fuels. Indeed; we know that neutron-free reactions cannot be ignited in the magnetic bottles developed for D-T and, unfortunately, little of the physics painstakingly developed for D-T fusion will apply. There is no clear path for an alternative scheme, and not coincidentally almost no support. As a result, only a few researchers are at work in the field. But it is clear that if we can build a reactor employing neutron-free fuels, we can avoid the enormous, probably insurmountable, problems posed by deuterium and tritium.

How could highly motivated and intelligent people get themselves into such a difficult situation? A fundamental reason concerns the difference between scientists' and engineers' view of what it means to solve a problem. Although they are usually able to agree on the definition of a "good problem," scientists and engineers often have different perspectives as to what constitutes a "good answer."

Good problems challenge our abilities to the limit but ultimately are solvable — that is they are not so difficult that the time spent is wasted. In both science and engineering, the greatest satisfaction accrues to those solving a problem first even though "better" (simpler or more complete) answers are often found later. In science such answers can coexist peacefully and are usually mutually illuminating. However, engineering answers must meet economic and social demands from the start, and fundamentally different answers rarely coexist for long.

Fusion is a textbook example of a good problem for both scientists and engineers. Many regard it as the hardest scientific and technical problem ever tackled, yet it is nonetheless yielding to our efforts. We have made substantial scientific progress, and the advances in fusion-system engineering have been astounding. We have developed superconducting magnets that dwarf ordinary laboratory magnets. Today's particle beams are nearly a million times more powerful than those available at the beginning of the program. We routinely fill huge devices with ionized gases at temperatures of tens of millions of degrees and use lasers to measure their properties. The fusion program has stretched our abilities to the utmost, and we have responded.

The fusion program was, from its inception, dominated by scientists. In the best tradition of science, we chose the most promising target— D-T fusion — out of the dauntingly complex areas of thermonuclear physics, and we concentrated on it. We may well achieve that goal, which would be a scientific triumph. But the scientific goal turns out to be an engi-

neering albatross. From the engineering point of view, we should have started from the answer and worked backward.

The second reason why intelligent and motivated people were led astray in fusion research is common to government programs that must compete annually for funds. There is a strong temptation to choose a near-term answer over a more rational long-term answer, even though this choice precludes reaching the ultimate goal. The alternative would be the much more difficult task of developing support for a long range program through persuasion and education. There is a related disinclination to adjust established plans, even if perceptions change. Indeed, it is considered dangerous even to admit uncertainty in a highly visible public program. Once established, an explicit goal, such as generating commercially competitive electricity from D-T fusion, is not easy to change.

As a result, the Office of Fusion Energy of the U.S. Department of Energy has promised that it will, early in the next century, demonstrate the production of large amounts of power via D-T fusion. Producing net power from fusion is a valid scientific goal, but generating electricity commercially is an engineering problem. The requirement is to develop a power source significantly better than those that exist today, and D-T fusion cannot provide that solution. Even if the fusion program produces a reactor, no one will want it.

The Science of Fission and Fusion

Fusion and fission power both have their roots in nature's tendency to favor the nuclear moderate: the elements of intermediate weight are energetically preferred—that is, the elementary particles forming the nucleus are more tightly bound. As a result, energy can be released either when heavy nuclei are split (fission) or light nuclei are joined (fusion). Fission is far easier to achieve than fusion. Several atoms with heavy nuclei, such as uranium-235 and plutonium-239, are on the verge of splitting spontaneously; adding a single nuclear particle causes instantaneous fission. The nucleus splits

into smaller fragments, releasing energy and several neutrons. These neutrons, because they are electrically neutral, can easily penetrate the electric barriers surrounding uranium and plutonium nuclei to cause additional fissions. This, of course, is the so-called “chain reaction.”

“Temperatures within a fusion reactor will range from the highest produced on earth to almost the lowest possible.”

The problems with fission almost all stem from the smaller fragments of the original nucleus. We have no control over which of the hundreds of different fission products are formed, and, unfortunately, many are noxious, radioactive, toxic, or corrosive. These fission products are primarily responsible for the problems of reactor safety, including waste disposal and even the possibility of a meltdown.

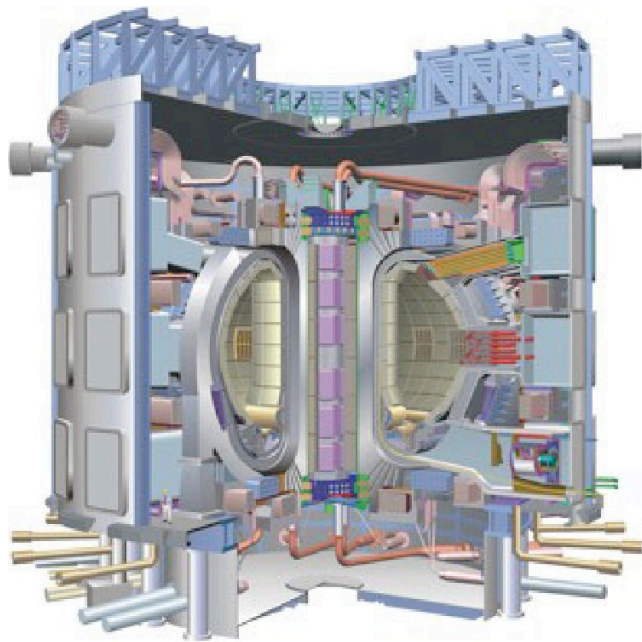

In the most likely scheme, called the “tokamak,” the tubular reactor is curved to form a torus (or doughnut).

Although fusion is conceptually simpler than fission; it is technically much more demanding. The root of the problem is that there is apparently no equivalent of the fission reaction that is induced by uncharged neutrons. All the nuclei that must be brought together for fusion are positively charged and, therefore, repel each another. This repulsive force between nu-

clei increases rapidly with increased atomic charge and becomes prohibitive for even moderately large atoms. Thus, it appears that fusion fuels must be chosen from among the lightest of elements — hydrogen, helium, lithium, beryllium, and boron. But despite the relatively small number of light elements, more than 100 fusion reactions are possible.

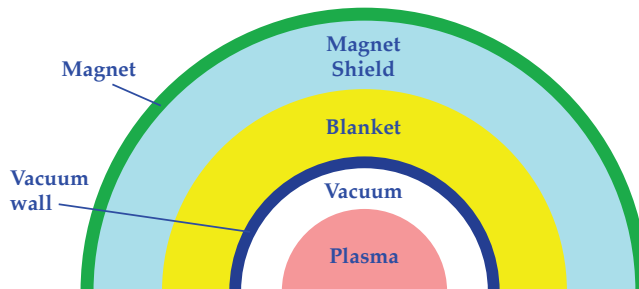

The schematic cross-section of proposed fusion reactors has remained essentially unchanged from one proposed in a 1961 textbook.

Temperatures in the plasma where fusion takes place would approach 150,000,000 C. The inner surface of the vacuum (or first) wall (dark blue) encircling the plasma will be subjected to intense heat and bombardment by damaging neutrons from the reaction. The “blanket” containing lithium, outside the first wall, absorbs these neutrons to “breed” tritium for fuel. The engineering will be complicated by the fact that lithium reacts explosively with air and water.

On the reactor’s exterior, the superconducting magnets that contain the plasma must be cooled almost to absolute zero. Hence the shielding to protect them from the extreme heat.

Despite the potential for problems in such a reactor, hands on repair will be impossible because of radioactivity. All in all, the proposed fusion reactor would be a large, complex, and unreliable way of turning water into steam.

Common to all is the fact that the reacting particles must be raised to very high energies (that is, must be very hot) to overcome their mutual electrical repulsion and approach close enough to fuse. Even at these very high energies, the particles are much more likely to bounce off each other at random angles — to “scatter” — than to fuse. Energy is conducted out of the system in this process. Thus, energy must be used to ignite fusion and to replace the energy continuously lost by the hot fuel. Obviously, the energy produced by the reaction must exceed the required input if the reactor is to be of any use.

But merely producing a net positive power output is not enough; achieving a high enough

power density is also crucial. Power density refers to the rate of energy production per unit of reactor volume. Fusion will almost certainly have a lower power density than fission and therefore will require a larger plant to produce the same output. Suppose a fusion plant had to be ten times as big and therefore likely ten times as costly — as a present-day fission plant to produce the same amount of power. Given the already intolerable costs of building fission plants, that would hardly be economically feasible. These issues of producing net energy and achieving a high enough power density are the dominant themes of fusion.

How Fusion Fuels Work

The choice of deuterium and tritium as fuels early in the fusion program evolved quite naturally. Deuterium is a non-radioactive isotope of hydrogen that, as mentioned, has one extra neutron in the nucleus. In nature approximately 1 out of every 6,500 hydrogen atoms is deuterium. Thus, it is abundant — after all, there is a lot of hydrogen in seawater — and separating it from ordinary hydrogen is straightforward because of the substantial disparity in the masses.

The first reaction seriously considered for fusion power plants was simply the self-fusion of deuterium — the D-D reaction. Deuterium reacts with itself to produce either helium-3, a stable but extremely rare isotope of helium, or tritium, the triply heavy isotope of hydrogen with two extra neutrons in the nucleus. These reaction products can themselves react with deuterium to produce even more energy than comes from the D-D reaction itself. Thus, a deuterium-fueled fusion reactor could, and almost certainly would, recycle and burn both the tritium and helium-3 in the so-called D-T and D-He³ reactions.

Calculating the energy available from this complex series of reactions is the first problem assigned to students in my introductory course in controlled fusion at MIT. If they do their work properly, the students find out that the energy released by fusing the deuterium in one

cubic meter of seawater equals that released by burning 2,000 barrels of crude oil. Every single cubic kilometer of ocean water therefore contains as much energy as the world's entire known oil reserves, and there are more than a billion cubic kilometers of water in the oceans. This astounding finding — in effect, an inexhaustible source of energy — shows why tens of billions of dollars have been spent and hundreds of scientists have devoted their entire careers seeking to tap this extraordinary energy source.

Unfortunately, making D-D reactions occur is extraordinarily hard, but there is an alternative. The tritium by-product that would be recycled in the D-D reactor is a far better fuel when mixed with deuterium than is deuterium itself. Not only is more energy released, but the combination of deuterium and tritium is 100 times more reactive than a simple mixture of deuterium. In other words, in similarly engineered reactors, a system fueled with deuterium and tritium will produce at least 100 times as much energy as one fueled by deuterium alone. Thus, as soon as scientists realized how difficult fusion was to achieve, they almost unanimously agreed that developing the D-T reactor should be the first goal of the fusion program. This scientific goal was well justified, and no one seriously questioned it as an engineering goal at the time.

One of the first issues posed by the D-T fusion reaction was how to supply sufficient tritium. Tritium is radioactive, with a relatively short half-life of 12.4 years, and therefore it exists only in minute quantities in nature. Luckily, the neutron emitted in D-T fusion can react with an isotope of lithium to produce tritium and even release additional energy in the process. Though nothing compares with the vast store of deuterium in seawater; the world's lithium resources are enough for several thousand years of energy production. The lithium-neutron reaction resolves the tritium-supply problem. However, it introduces additional engineering difficulties.

Fusion Reactors: Large and Complex

The severity of the technical problems associated with the D-T reaction was not fully understood in the early years of the fusion program. But these difficulties have gradually been revealed by the extraordinarily detailed series of conceptual reactor designs produced under Department of Energy (DOE) funding over the last decade. The object of these studies is to describe a plausible fusion reactor based on the underlying physics and reasonable extrapolations of the technology. Of course, no one can be certain exactly what a D-T fusion reactor will look like. Nevertheless, several difficult questions that might seem to depend on this knowledge can already be answered. In particular: will a fusion reactor be simpler or more complex, cheaper or more expensive, safer or more dangerous, than a fission reactor? The answers depend only on the broad outlines of future reactors.

The main fusion reaction will take place in a gas-like plasma in which deuterium and tritium atoms are so energetic — so hot — that the nuclei have lost their electrons. The temperature of this gas will probably exceed $150,000,000^{\circ}\text{C}$. This plasma cannot be contained by physical walls, not only because no material could withstand the heat, but also because walls would contaminate the plasma. Instead, the plasma will be bottled within a vacuum by magnetic forces,

Four-fifths of the energy from the D-T reaction is released in the form of fast-moving neutrons. These neutrons are 15 to 30 times more energetic than those released in fission reactions. The first wall surrounding the plasma and vacuum region will take the brunt of both the neutron bombardment and the electromagnetic radiation from the hot plasma. This first wall is expected to be made of stainless steel or, better, one of the refractory metals such as molybdenum or vanadium that retain their strength at very high temperatures.

In colliding with this wall, the neutrons will give up some of their energy as heat. This heat

must be removed by rapidly circulating coolant to prevent the wall from melting. After being piped out of the reactor, the heated coolant is used to produce steam and generate electricity.

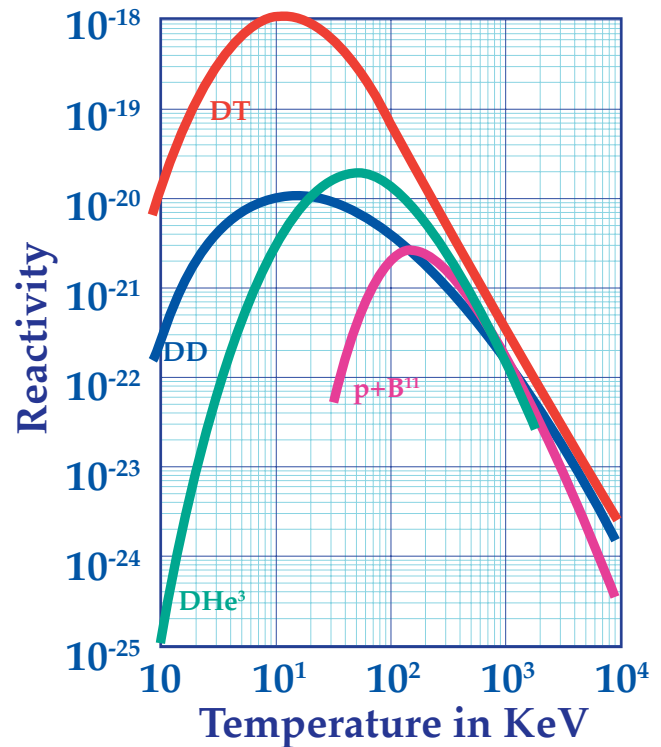

The fusion of deuterium (D) with tritium (T) is 100 to 1,000 times more reactive than the fusion of combinations involving helium 3 (He^3), protons (p), or boron 11 (B^{11}). In other words, a DT based power plant would yield 100 to 1,000 times more energy than an identical plant using the other fuels. That is why almost all research has focused on D-T fusion. However, the energetic neutrons it releases would damage and induce radioactivity in the reactor structure.

Many of the collisions between neutrons and atoms in the first wall actually knock the atoms forming the metal out of their original positions. Each atom in the first wall will, on average, be dislodged from its lattice position about 30 times per year. Obviously, this causes the structure of the metal to deteriorate.

A few of the neutrons colliding with atoms in the first wall will have the beneficial effect of dislodging some neutrons from the atomic nuclei. These dislodged neutrons, plus the original ones generated by the fusion, pass through the wall and into the so called “blanket,” which contains lithium in some form. Here, the bulk of their energy is used to produce heat, which also is used to create steam for generating elec-

tricity, and eventually the neutrons are absorbed by the lithium to “breed” tritium.

Lithium itself poses serious engineering problems. It is an extremely reactive chemical: it burns violently when it comes in contact with either air or water and even capable of undergoing combustion with the water contained in concrete. The lithium may be either in liquid form or in a solid compound. Liquid lithium blankets produce substantially more tritium and allow it to be more easily removed. However, the need to handle large amounts of this metal in liquid form leads to technical complexity and poses safety hazards.

The tritium-breeding region has other engineering requirements. It must be designed in such a way that the structural materials, as contrasted with the actual lithium, capture a minimum of neutrons. Also, the operating temperature must be high enough so that the coolant, when piped outside the reactor, can generate steam efficiently.

Outside the blanket, powerful magnets must provide the magnetic fields to contain the plasma. These fields will exert enormous forces on the magnets themselves, equivalent to pressures of hundreds of atmospheres. If made from copper wire, these magnets would consume more power than produced by the reactor, so they will have to be superconducting. Superconducting magnets, cooled by liquid helium to within a few degrees of absolute zero, will be extremely sensitive to heat and radiation damage. Thus, they must be effectively shielded from the heat and radiation of the plasma and blanket.

Temperatures within the fusion reactor will range from the highest produced on earth (within the plasma) to practically the lowest possible (within the magnets). The entire structure will be bombarded with neutrons that induce radiation and cause serious damage to materials. Problems associated with the inflammable lithium must be managed. Advanced materials will have to endure tremendous stress from temperature extremes and damaging neutrons. The magnetic fields will

exert forces equivalent to those seen only in very high pressure chemical reactors and specialized laboratory equipment. All in all, the engineering will be extremely complex.

A working fusion reactor would also have to be very large. This conclusion is based on fundamental principles of plasma physics and fusion technology. To begin with, because of the properties of magnetic fields, a fusion reactor must be tubular. There is still dispute as to whether this tube should be bent into a toroidal (doughnut) shape, as in the device known as the “tokamak,” or kept as a long, straight tube with end plugs, as in the device known as the “tandem mirror.” However, the main conclusions as to the size and complexity of a D-T reactor are independent of this choice.

The first wall of the reactor encloses the plasma. The best theories available suggest that the radius of the plasma must be at least two to three meters if the fusion reaction is to be self-sustaining. Even if a breakthrough in physics were to allow a smaller plasma, separate engineering requirements would prevent the radius of the first wall from being appreciably less than three meters. These requirements arise from the need to avoid excessive differences in power density.

“A fusion reactor might well produce only one-tenth as much power as a fission reactor of the same size.”

For the neutrons to be slowed enough in the lithium to effectively breed tritium, the blanket surrounding the first wall must be between half a meter and one meter thick. The radiation shield outside the blanket must also be between half a meter and one meter thick to protect the supercooled magnets. Finally, the superconducting magnets and their structure will add another meter each to the radius. That gives a total radius of at least five meters for the plasma and the tube surrounding it.

In a tokamak reactor, this tube — over 30 feet across — would be bent into a doughnut-like shape at least 75 feet in outer diameter. As a power plant, this is somewhat larger than to-

day's fission reactors and substantially more complex. If the energy density of the fusion plant turned out to be lower than that of a contemporary fission plant, as seems likely, then all this size and complexity would produce less power—hardly an economic proposition. But even if the power density were comparable, the D-T fusion reactor would, like today's fission plants, be a large and costly power source, producing thousands of megawatts of electricity. Detailed studies, some costing millions of dollars, aimed at deducing the smallest plausible size for a D-T fusion reactor all come to this same discouraging conclusion.

Such a large reactor would not meet the needs of utilities. Plagued by financially crippling cost overruns on fission reactors, managers are loathe to invest several billion dollars in any single plant, fission or fusion. Smaller plants, such as coal plants with scrubbers, are much easier to finance, not only because the investment is far lower, but also because the final cost is predictable. And if a small plant breaks down, the effects on regional electricity production are much less serious. Thus; utility managers find large plants undesirable.

Suppose fusion reactors could be built despite the inherent difficulties of size and complexity. Another critical engineering problem would still have to be faced. That is the matter of heat transfer — the way in which heat is removed from the reactor structure by the circulating coolant. The history of much large scale power engineering has been dominated by the effort to achieve ever higher temperatures and heat transfer rates. High temperatures imply high efficiency, and high heat-transfer rates imply high power density. Because these goals are so desirable, heat transfer systems have been pushed close to their limits. Above these limits, materials either melt or fail from excessive stress caused by heat. Additional gains are coming only slowly.

Consider heat transfer in fission and fusion reactors. In today's typical light-water reactor (LWR), there is generated by fission in fuel pins containing uranium. The heat is then

transferred to the coolant at the surfaces of a relatively large number of small diameter pins. This arrangement provides a larger surface area to transfer heat than, say, a single large fuel cylinder. Indeed, by decreasing the diameter of the pins even further (but increasing their number to keep the amount of uranium unchanged), the total surface area available to transfer heat would be further increased. Thus, the actual heat-transfer rate through any given square inch of surface on a fuel rod is not critical. Sufficient heat can always be removed merely by increasing the total area.

This strategy does not work in a fusion reactor. The heat-transfer surface is limited to the inside of the wall surrounding the plasma, and the relatively small surface area of this wall cannot be increased without further increasing the size of the reactor. In fact, bigger reactors need larger heat-transfer rates. Thus, the actual heat-transfer rate per square inch must be extremely large and cannot simply be reduced by a design change.

Suppose a fission reactor and a fusion reactor were built with equivalent heat-transfer rates. Knowing this, one can calculate two other critical engineering factors: the flux of neutrons at the heat-transfer surface, and the overall power density of the reactor. The neutron flux should, of course, be as low as possible, because it damages the reactor structure and makes it radioactive. And the power density should, as mentioned, be as high as possible, so that a reasonable amount of power will be produced in a reactor of a given size.

On these counts, a comparison between current LWR fission reactors and the somewhat optimistic fusion designs produced by the DOE studies yields a devastating critique of fusion. For equal heat-transfer rates, the critical inner wall of the fusion reactor is subject to ten times greater neutron flux than the fuel in a fission reactor. Worse, the neutrons striking the first wall of the fusion reactor are far more energetic — and thus more damaging — than those encountered by components of fission reactors. Even in fission reactors, the lifetimes

of both the replaceable fuel rods and the reactor structure itself are limited because of neutron damage. And the fuel rods in a fission reactor are far easier to replace than the first wall of the fusion reactor, a major structural component.

“The drawbacks of the existing fusion program will weaken the prospects for other fusion programs, no matter how wisely redirected.”

But even though radiation damage rates and heat transfer requirements are much more severe in a fusion reactor, the power density is only one-tenth as large. This is a strong indication that fusion would be substantially more expensive than fission because, to put it simply, greater effort would be required to produce less power.

Fusion’s Benefits

Given all of fusion’s liabilities, why are we working so hard on it? The universal availability of fuel has provided a strong motive to develop fusion, and it does promise some other substantial advantages over fission. To begin with, fusion generates much less radioactivity than fission, and there is no long-term storage problem for radioactive wastes. A fusion reactor would create a lot of tritium, which is radioactive and hard to contain. However, tritium’s biological effects are relatively benign — it does not tend either to concentrate or to linger in living organisms—and it emits relatively weak radiation. After a short period of operation, the radioactivity from neutrons bombarding the structure of a fusion reactor itself would greatly exceed the feeble radioactivity of the tritium.

But even the radioactivity of the structure will be composed primarily of nonvolatile isotopes. By contrast, a substantial amount of the radioactivity in fission reactors is in the form of volatile gases that can escape if the containment structure is breached. To further minimize the radioactivity associated with fusion, reactor designers can choose structural materi-

als that do not become strongly radioactive when bombarded by neutrons.

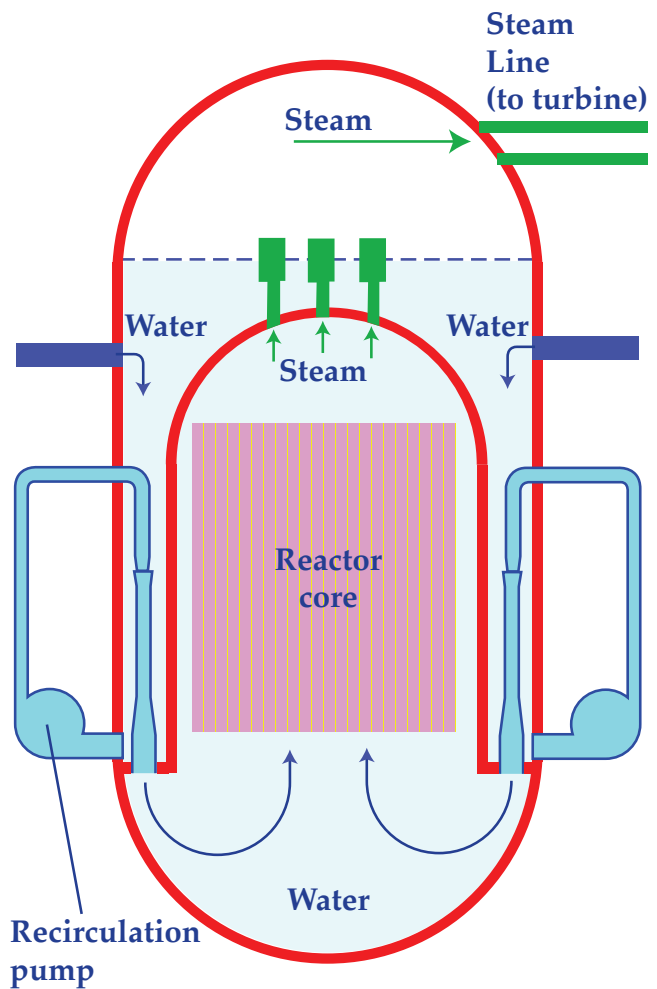

In a fission reactor, heat from the reaction is released through the surfaces of thousands of fuel rods. Additional surface area to transfer heat can be created by providing more fuel rods but making them thinner.

However, in fusion plants, the $150,000,000^{\circ}\text{C}$ plasma is encircled by a “first wall,” the surface of which cannot be increased in any practical way. (If the encircling wall is made bigger, then the larger plasma creates even more heat.) Thus, as much energy as possible must be transferred through each square inch of the first wall. Unfortunately, improvements in heat transfer rates are coming only slowly.

A fusion reactor of stainless steel would have 300 times less radioactivity than a fission reactor of the same power output. A fusion reactor based on a vanadium structure would be 10 times better yet. In other words, it seems possible to build a fusion reactor with 3,000 times less radioactivity than a fission reactor producing the same amount of power.

The radiological difference between fission and fusion is even more striking in the production of long lived wastes. There is nothing in the fusion reactor comparable to the fission fragments or the plutonium in fission reactors. Plutonium is extremely hazardous and its radioactivity is very long-lived, with a half-life of 24,100 years. After a 100-year storage period, the radioactive waste produced by a stainless-steel fusion reactor would be 1 million times less hazardous than that produced by an equivalent fission reactor. And there would be no need to store the waste of a fusion reactor with a vanadium structure even that long. A well-designed fusion reactor could completely eliminate the problem of storing long-term waste.

The fact that a fusion reactor does not require long-term waste storage seems a clear advantage. But it is less significant than would first appear, for we have tended to exaggerate the waste-storage problems of fission reactors, primarily because of ill-considered decisions early in their development. Early schemes for disposal of fission wastes had to be inexpensive to allow the reactors to compete with conventional power plants fueled by inexpensive oil. Early schemes for disposing of the wastes—dumping them on the ocean bottom or injecting them into underground strata were certainly cheap. However, these schemes were so clearly inadequate that the fission community did its reputation lasting damage by advocating them.

“Neutrons induce radioactivity and damage reactors. Neutron-free fusion might provide inexhaustible, benign power.”

Although the public is still concerned about the disposal of radioactive waste, the economic situation is now completely changed. Fission products can be safely stored, as is routinely done in Europe now. To be sure, such processes are not inexpensive. For example, one technique consists of sealing intact fuel elements in welded metallic canisters and storing them in mined granite cavities. If better techniques for

storage should become available, the wastes can be retrieved. The costs of such relatively expensive disposal still play only a small role—less than 10 percent—in the total price of power. Public perception changes slowly, but the time scale under consideration is long. Waste disposal will eventually be considered a difficult but not insurmountable problem.

The matter of safety is difficult to weigh so concretely. Current analyses show that the probability of a minor mishap is relatively high in both fission and fusion plants, because both contain many complex systems. But the probability of small accidents is expected to be higher in fusion reactors. There are two reasons for this. First, fusion reactors will be much more complex devices than fission reactors. In addition to heat-transfer and control systems, they will utilize magnetic fields, high power heating systems, complex vacuum systems, and other mechanisms that have no counterpart in fission reactors. Furthermore, they will be subject to higher stresses than fission machines because of the greater neutron damage and higher temperature gradients. Minor failures seem certain to occur more frequently.

Comparing the probability of more serious accidents is harder, partly because that issue is the subject of such heated debate concerning fission reactors. But the probability of major accidents affecting public safety will certainly be substantially lower for fusion reactors. Indeed, the hypothetical worst-case accident of a fission reactor catastrophic meltdown with release of fission products has no equivalent in fusion. The fusion reactor simply does not contain enough radioactive material.

Thus, fusion reactors will have a higher probability of small accidents but a much lower probability of major accidents. This at first appears to be a strong argument for fusion, but consider Three-Mile Island. This accident, thought by some to have sounded a death knell for the fission industry, may have had equally damaging consequences for fusion. Although no one was physically injured in the TMI acci-

dent, the utility owning the reactor was mortally wounded financially. The multi-billion-dollar plant was put out of commission because it was too radioactive to repair. From a manager's standpoint, all systems that are too radioactive for hands-on maintenance are equivalent: if something major breaks, it is unrepairable. Although there is much less radioactivity in a D-T fusion reactor than in a fission reactor, it is still so high that contact maintenance would be impossible. And a D-T fusion reactor would be far more likely than a fission reactor to require repairs.

The analysis of safety factors comes down to this: While the public is primarily concerned about major catastrophes, power-plant operators are also fearful of less threatening accidents that could cause serious financial problems. In respect to these, fusion is at a disadvantage. If this factor is added to the reactor's high initial cost, large size, and poor power density, D-T fusion becomes an unacceptable financial risk.

The public perception of fusion as ultimately safer than fission cannot nullify this. Furthermore, in a broader sense the safety of a D-T fusion reactor would depend on its being used responsibly. **One of the best ways to produce material for atomic weapons would be to put common, natural uranium or thorium in the blanket of a D-T reactor, where the fusion neutrons would soon transform it to weapons-grade material.** And tritium, an unavoidable product of the reactor; is used in some hydrogen bombs. In the early years, research on D-T fusion was classified precisely because it would provide a ready source of material for weapons. Such a reactor would only abet the proliferation of nuclear weapons and could hardly be considered a wise power source to export to unstable governments.

A major driving force behind fusion has been the promise of abundant fuel. Indeed, the fusion program was originally justified not on safety grounds — fission's safety was not widely doubted then — but because of the expected rapid depletion of uranium reserves. But this is

no longer a major concern. One reason is the declining demand for additional fission power and hence for the uranium to fuel it. The earth's reserves of uranium are now known to be large enough to supply fission reactors for at least 50 to 70 years without fuel reprocessing.

Probability of a reactor accident per year

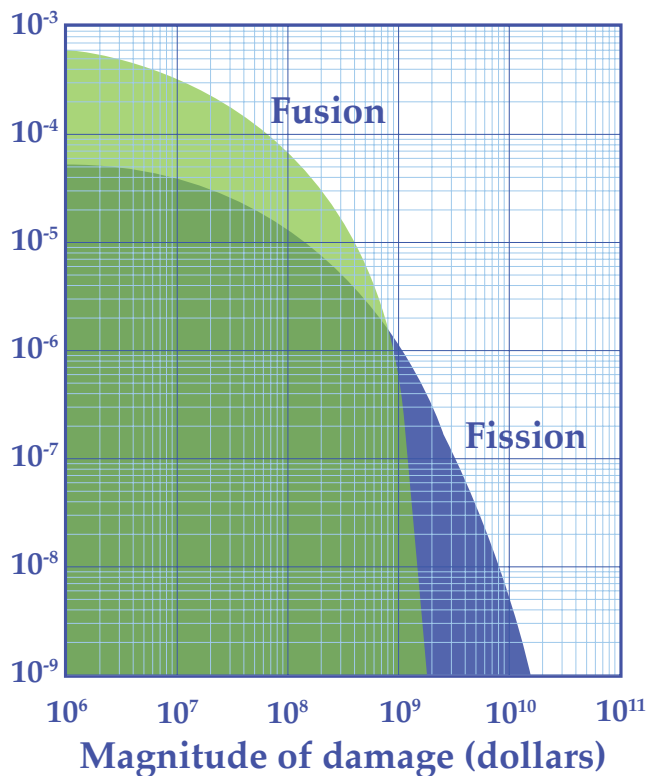

The worst possible accident for a fusion reactor would destroy only the power plant itself — a minor hazard compared with the possibility of a meltdown in a fission reactor. However, a fusion reactor would be far more complex and prone to minor accidents. Since the fusion reactor would be too radioactive for hands on repair, any accident could pose grave financial consequences for utilities. (The general shapes in the diagram are correct; however, the actual numerical values are uncertain and should not be taken literally.)

There has also been a breakthrough in the technology for removing uranium from seawater. A Japanese consortium is starting up a pilot plant that uses an efficient filter to trap and concentrate the extremely dilute uranium in seawater. **This technology will make available virtually unlimited supplies of uranium** at a

cost at most ten times the current (depressed) price for conventionally mined uranium. The cost of nuclear fuel is so small a fraction of the total cost of generating electricity that the new technology would increase electricity prices only negligibly. The same oceans that could supply fusion fuels can also supply fission fuel; the abundance of deuterium for fusion ceases to be a compelling argument.

Dim Prospects for D-T Fusion

In retrospect, it is not totally surprising that fusion should fare so poorly in comparison with fission. The problem is simply that in fusion, 80 percent of the energy is released in neutrons with an energy of 14 million electron volts (MeV) that travel about 50 centimeters. In fission, less than 3 percent of the energy is released in neutrons, and these have an energy of only 1 to 2 MeV. Most of the fission products are highly charged nuclei that travel less than .001 centimeter before coming to rest.

“The scientific goal of the fusion program turns out to be an engineering nightmare.”

Thus, while the major radioactivity from fission is contained within the fuel pins, the major radioactivity from fusion would damage the reactor structure and create problems of complexity, unreliability, and size. While fission’s numerous wastes pose problems of disposal and reactor safety, fusion’s neutrons could easily be used to manufacture material for atomic weapons. It is hard to see why a utility in need of additional generating capacity would purchase a D-T fusion reactor instead of a contemporary LWR fission reactor. And as far as most utilities are concerned, even the LWR no longer seems a good choice.

The early history of the fission program was similar to current experience in the fusion program except that success in fission came too easily. As soon as we found a concept that worked reasonably well, powerful forces drove that machine, the LWR, to prominence. We did not take the time to test, modify, and fi-

nally choose the “best” nuclear reactor among many competitors.

Now we know that safer, smaller, and probably cheaper fission reactors can be built. In fact, reactors could be small enough to be assembled in a factory and shipped via truck, reactors so safe that no operator error or even loss-of-coolant accident could cause release of radiation. The dreaded meltdown would also be impossible in these small, “modular” reactors. Such a reactor has been operating for 15 years in Germany. To be sure, this kind of reactor would probably not be the best choice in a world in which uranium was scarce and reprocessing and fuel breeding were necessary. But we do not live in such a world. Unfortunately, the resounding crash of the LWR has prejudiced the possibility of a new beginning for fission reactors.

The only real hope for fusion is to take the long view ignored in the fission program. Neutron-free fusion is a quintessential example of a high-risk, high-gain area of physics that might also provide a good answer to an engineering problem. We have no guarantee that an answer exists. But we know that if it does, it can meet the original goal of the fusion program — universally available, inexhaustible, environmentally benign power. Perhaps we should not be greatly troubled that our first attempt to develop such a marvelous thing will not be the success we had hoped. We can go on to seek a better alternative.

LAWRENCE M. LIDSKY, professor of nuclear engineering at MIT, is an associate director of the Plasma Fusion Center and editor of the *Journal of Fusion Energy*. He has worked on plasma physics and fusion-reactor technology for 20 years.

Appendix — Neutron-Free Fusion

Almost all of the lighter elements are capable of entering into fusion reactions in which the nuclei of atoms are combined and energy is released. The prime candidates for power producing reactions are based on two isotopes of hydrogen: protons (p) which are the standard hydrogen nuclei, and “heavy hydrogen” or deuterium (D) which has a neutron attached to the proton. The nuclei of the hydrogen isotopes have the lowest possible electric charge — one positive charge. Thus, they require lower energies to be brought together for fusion reactions than other nuclei with larger positive charges.

The original proposal for fusion was to produce power through the self-fusion of deuterium — the D-D reaction. This reaction produces with equal probability, either the light helium isotope with two protons and a neutron (He³) or the heaviest hydrogen isotope, tritium (T) with one proton and two neutrons. Both reactions release energy, generally measured in millions of electron volts (MeV).

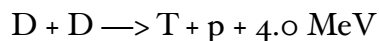
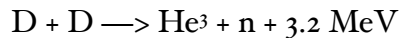

These reaction products can themselves react with deuterium and will either be “burned” in place or recycled.

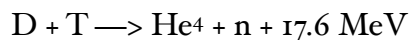

Because the fuel for the last two reactions is generated in the first two, only deuterium need be supplied externally. The final reaction products — ordinary helium and hydrogen — are benign, but the energetic neutrons can damage and induce radioactivity in the structure of the reactor.

Fusion based on any fuel cycle containing deuterium produces undesirable neutrons. The reason is this: most of the deuterium can be made to “burn” in a desired reaction — for example the benign D-He³ fusion above, to produce ordinary helium, a proton, and energy. But some of the deuterium in the mixture will

also collide with itself, producing neutrons and radioactive tritium; further collisions with the tritium will produce more neutrons.

Fuel cycles based on protons tend to produce far lower amounts of neutrons. The lithium-6 reaction:

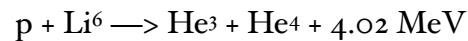

is often considered because of the low charge of both constituents. But it is not completely neutron-free. A product (He³) can react with Li⁶ to produce neutrons via a low probability, but nonetheless troublesome, side reaction.

From an engineering point of view, the boron-11 reaction:



is nearly ideal. Neither the fuel nor the end products are radioactive. Furthermore, no neutrons capable of inducing radioactivity are produced.

Because all the products of the boron-11 reaction are charged, they could theoretically be harnessed to generate electricity directly, without the inherent waste of generating steam to run a turbine. However, the high electric charge of boron (it has 5 protons) makes the task of designing an energy producing system very difficult.

2007 Postscript

Professor Lidsky (October 15, 1935 to March 1, 2002) wrote this article because, “I couldn’t get an internal discussion going. Some didn’t care and some didn’t want to know.” A short time after the article appeared, he resigned his position at the Plasma Fusion Center.

As MIT Professor Jeffrey Freidberg observed, “He was one of the earliest engineers to point out some of the very, very difficult engineering challenges facing the program and how these challenges would affect the ultimate desirability of fusion energy. As one might imagine, his messages were not always warmly received initially, but they have nevertheless stood the test of time.”