

Nuclear transmutation induced by deuterium permeation through the Pd complexes detected by surface and bulk analysis methods

**Yasuhiro Iwamura¹, Takehiko Itoh¹, Mitsuru Sakano¹, Noriko Yamazaki¹,
Shizuma Kuribayashi¹, Yasuko Terada² and Testuya Ishikawa³ and
Jirohta Kasagi⁴**

¹Advanced Technology Research Center, Mitsubishi Heavy Industries, Ltd.

²Japan Synchrotron Radiation Research Institute

³Coherent X-ray Optics Laboratory, SPring-8/RIKEN

⁴Laboratory for Nuclear Science, Tohoku University



ICCF-11, Marseilles, France, October31-November5, 2004

Contents

1. Introduction

2. Experimental method and the Results so far

3. Experimental Results and Discussion

3-1 Transmutation of ^{137}Ba and ^{138}Ba into ^{149}Sm and ^{150}Sm

: Mass distribution of Sm depending
on the given mass distribution of Ba

3-2 Pr confirmation by XRF and experiments for
in-situ measurement at SPring-8

3-3 Consideration on the role of CaO layer

4. Concluding Remarks

Features of the Present Method

D₂ gas permeation through the Pd complex

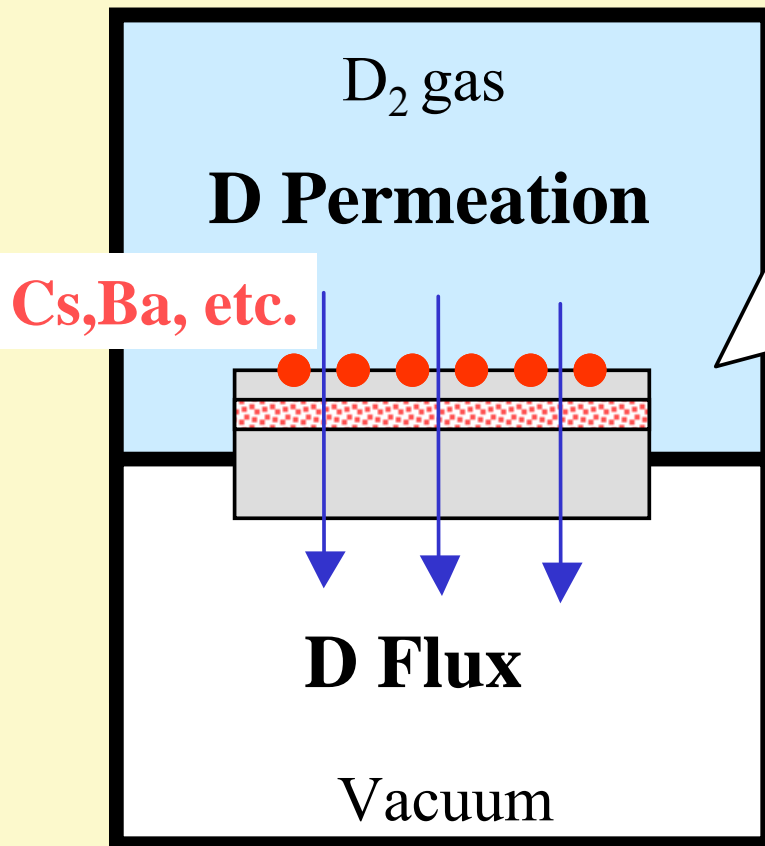

Cross Section of Pd Complex

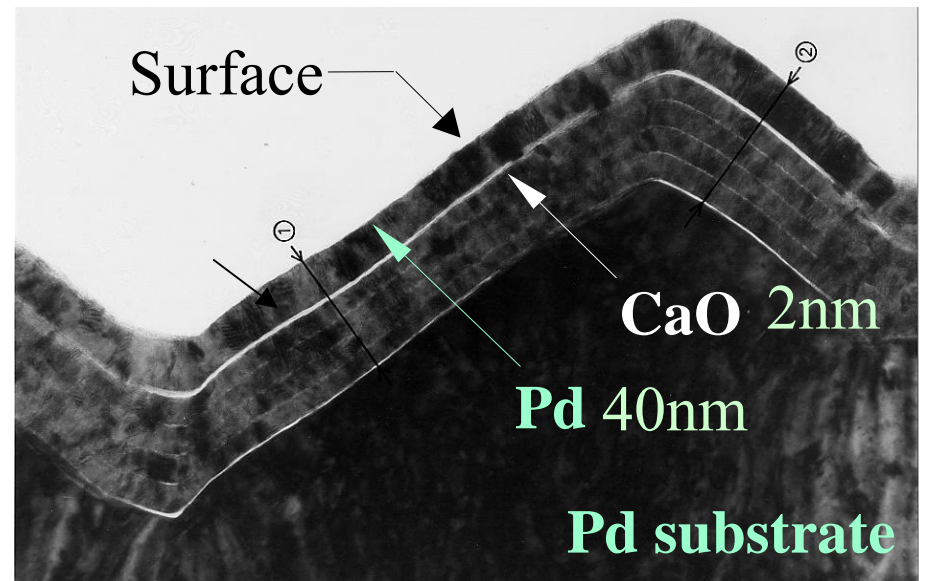

Fabrication of Pd Complex

Washing a Palladium Sample with Acetone



900° C 10H Annealing under Vacuum
Condition ($< 10^{-7}$ Torr)



Washing the Sample with Aqua Regia (100sec)



5 times Alternatingly Sputtering of
CaO(20 Å) and Pd(180 Å)



Ion Beam Sputtering of Pd only (400 Å)

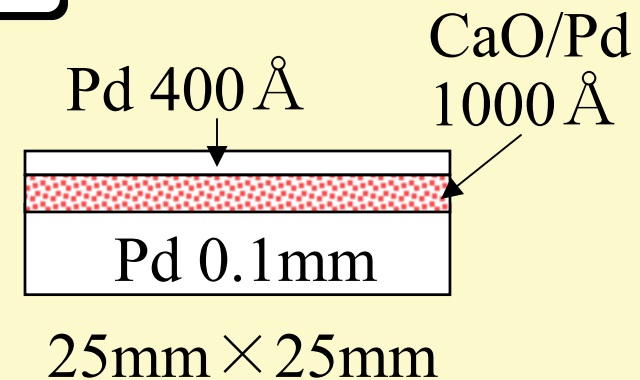

Schematic View of the Experimental Apparatus

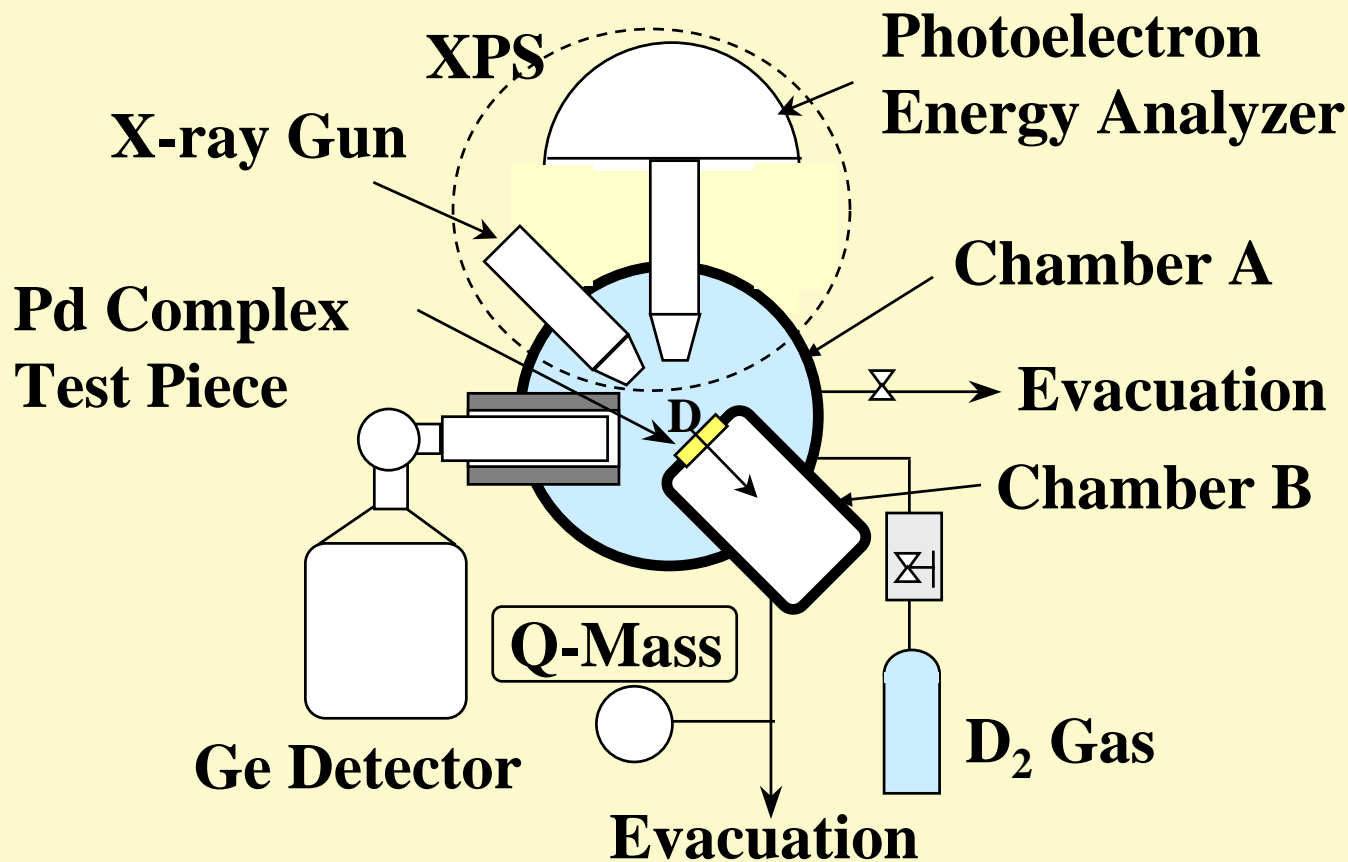

Photograph of the Experimental Setup

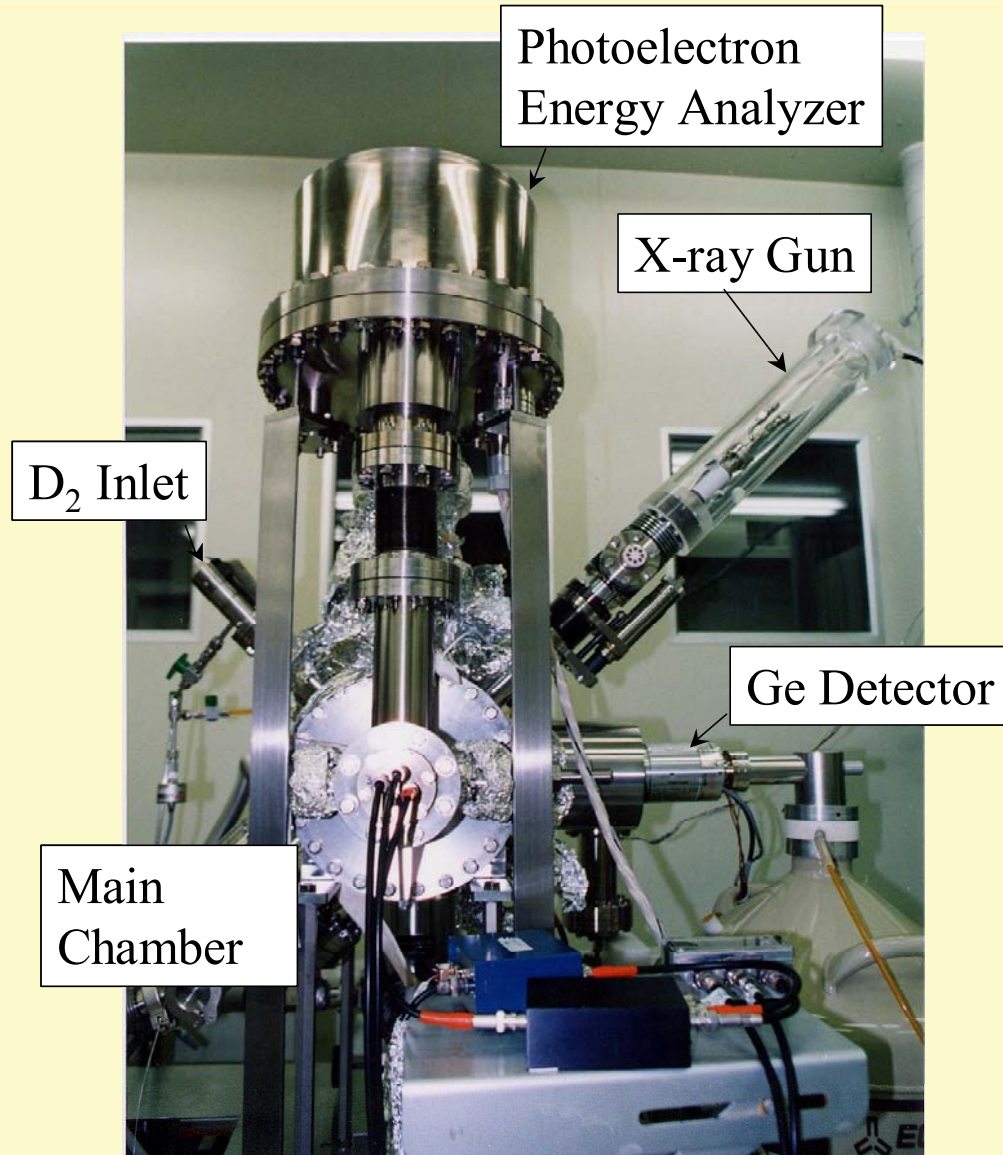

Decrease of Cs and Emergence of Pr

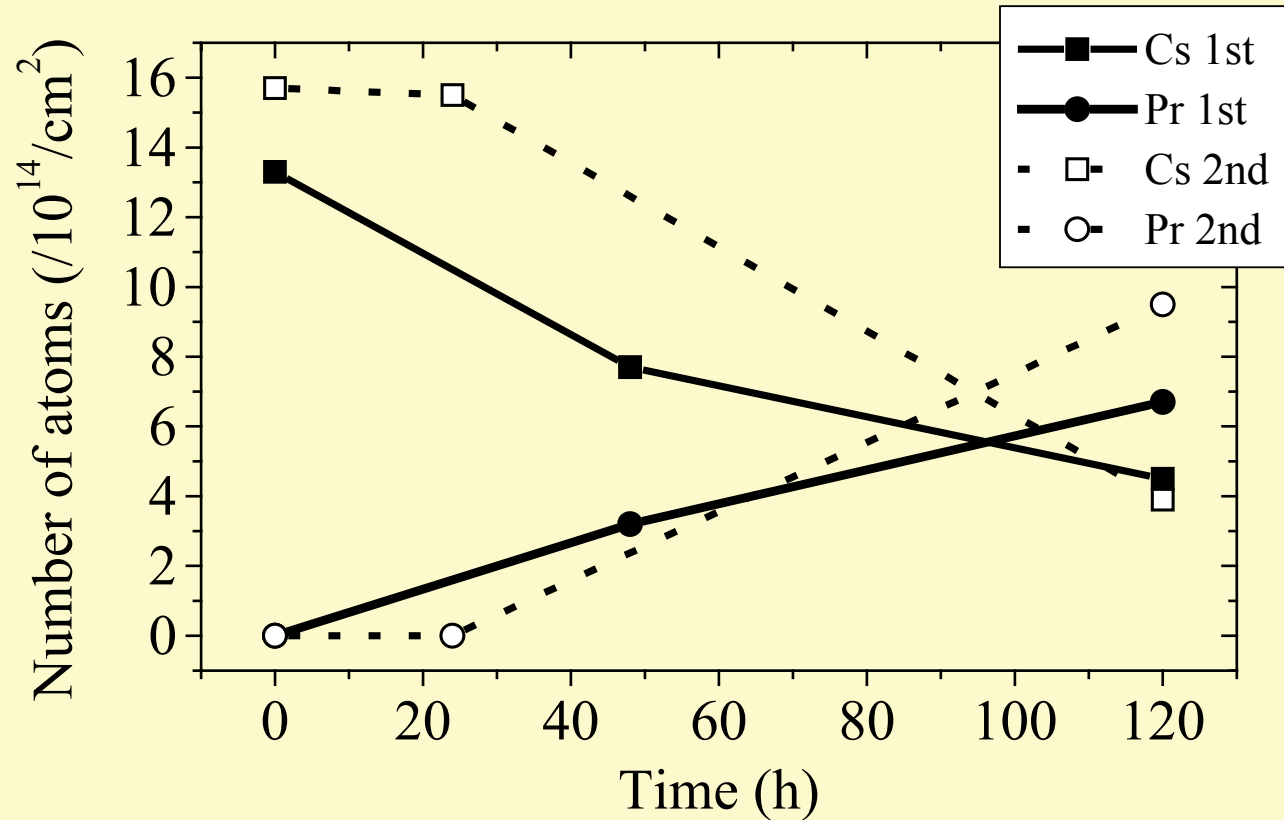
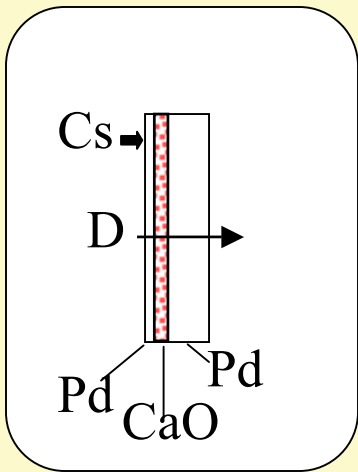

Identification of Pr by TOF-SIMS

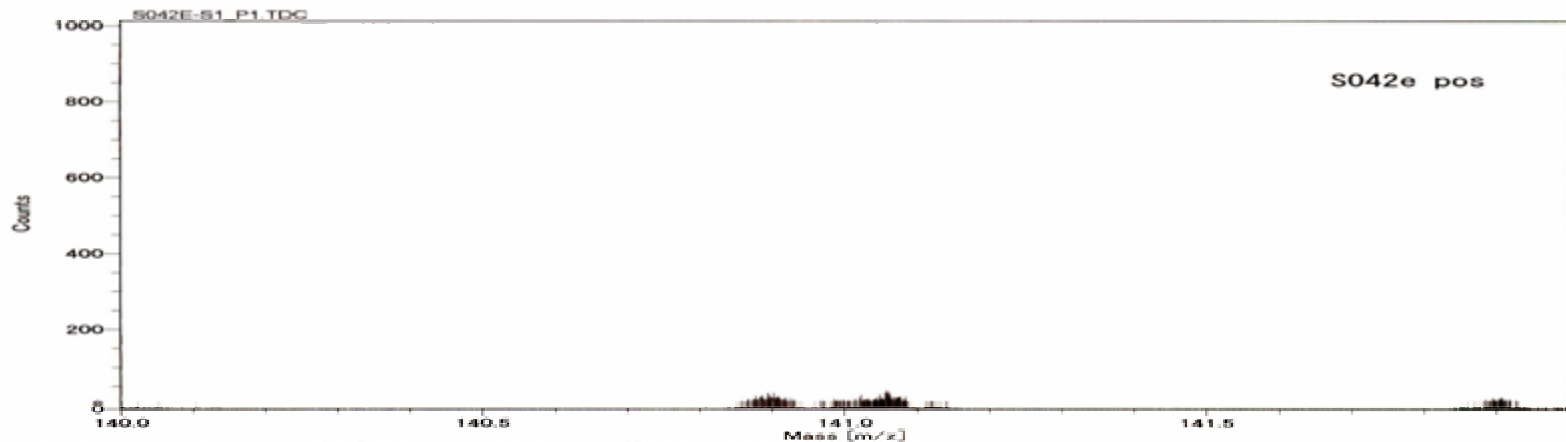
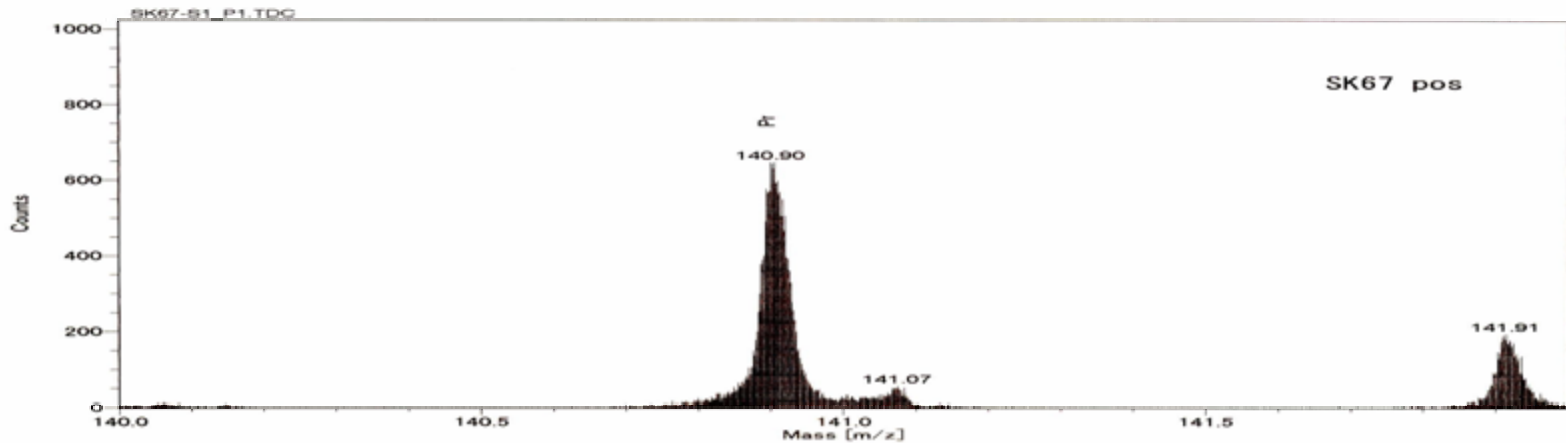

SK67-S1_p1.tdc 3.8 min on 8月 30, 2001 + ions 5320416 cts (100.0 x 100.0 μ m) using LMIG
S042e-S1_p1.tdc 3.9 min on 8月 30, 2001 + ions 5343585 cts (100.0 x 100.0 μ m) using LMIG

TOF-SIMS device (TRIFTTM II ;ULVAC-PHI)

Correlation between D₂ Permeation and Conversion Rate

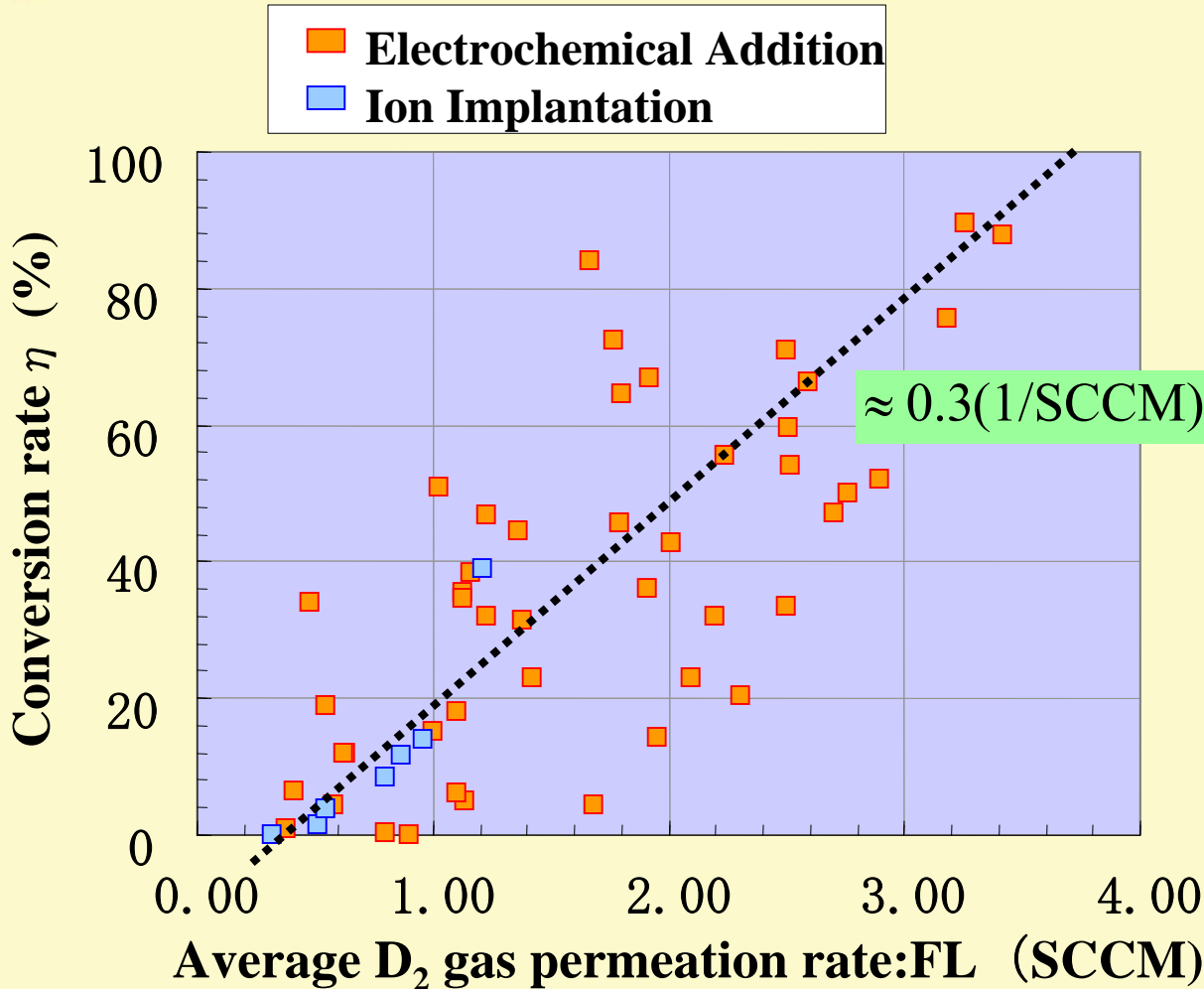

$$\eta = \frac{N_{Pr}}{N_{Cs}} \times 100\%$$

$$= \frac{N_{Pr}}{N'_{Cs} + N_{Pr}} \times 100\%$$

η : conversion rate(%)

N_{Pr} : detected Pr (ng)

N_{Cs} : given Cs (ng)

N'_{Cs} : detected Cs after
an experiment (ng)

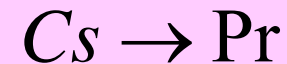

Positive Correlation between D₂ permeation and Conversion Rate

Decrease of Sr and Emergence of Mo

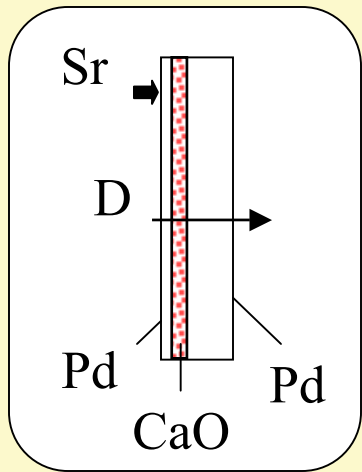

Number of atoms ($/10^{14}/\text{cm}^2$)

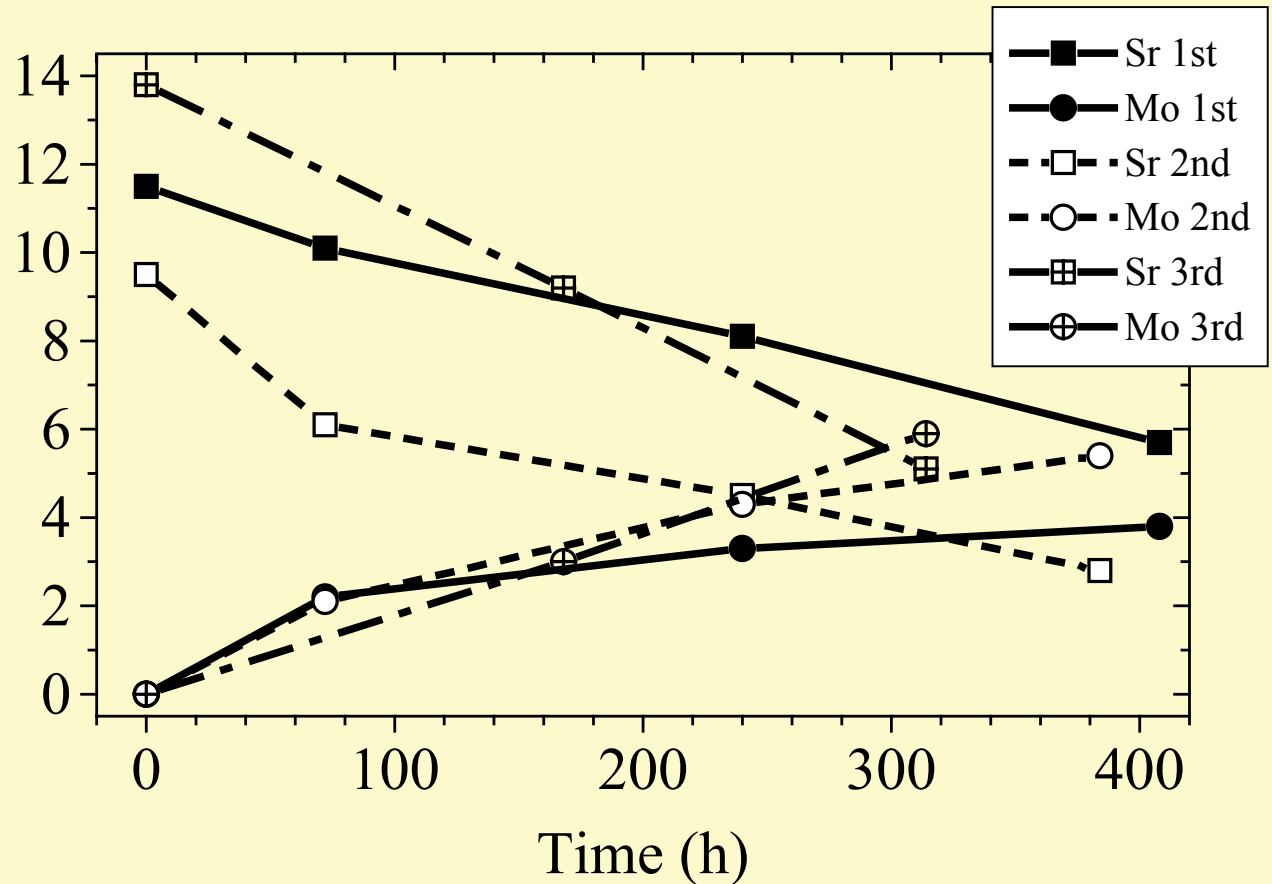

Relation of Isotopic Composition between Sr and Mo

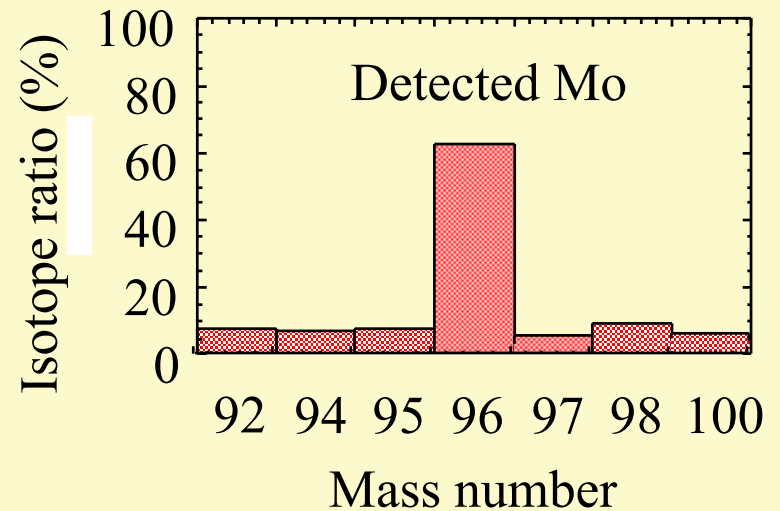
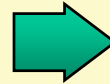
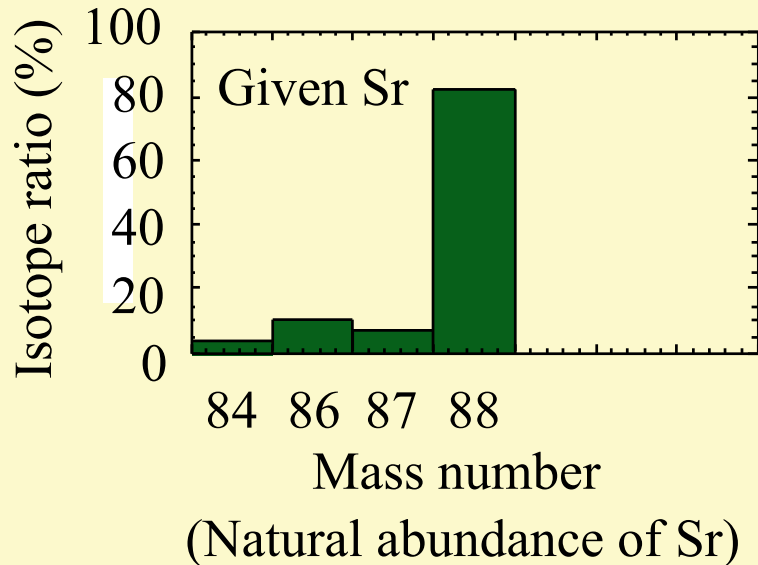

Mass N. +8

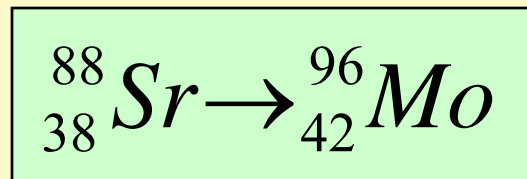

Atomic N. +4



Mass N. +8

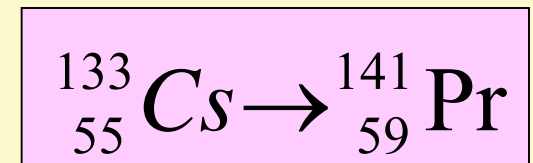

Atomic N. +4

Recent Results; Part 1

**Transmutation of ^{138}Ba into
 ^{150}Sm and ^{137}Ba into ^{149}Sm**

Transmutation of Ba into Sm; Natural Ba

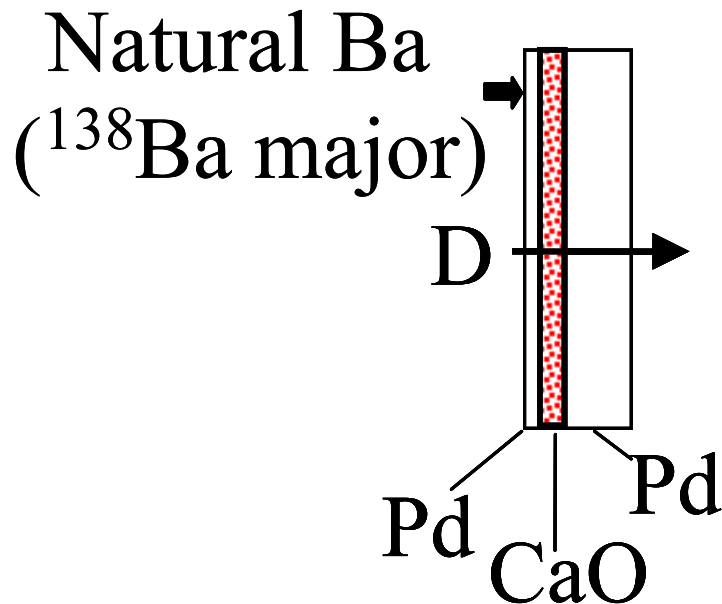

^{150}Sm was detected
after D permeation
on the Pd complex

Schematic View of the Ex-situ Measurement Apparatus

MITSUBISHI HEAVY INDUSTRIES, LTD.
ADVANCED TECHNOLOGY RESEARCH CENTER

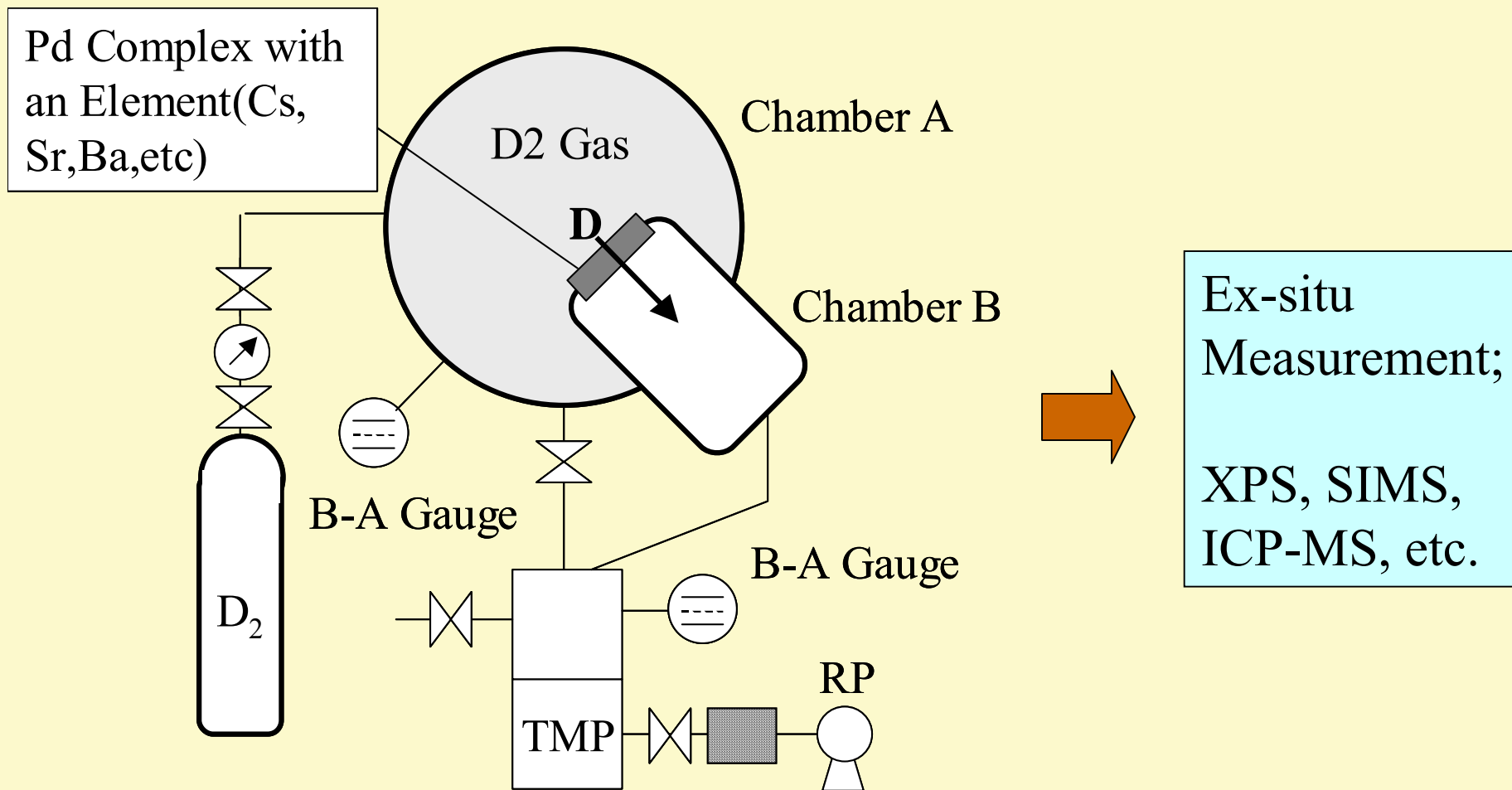

Fundamentals of XPS

Al, Mg k-Xray;
1.4 or 1.3 keV

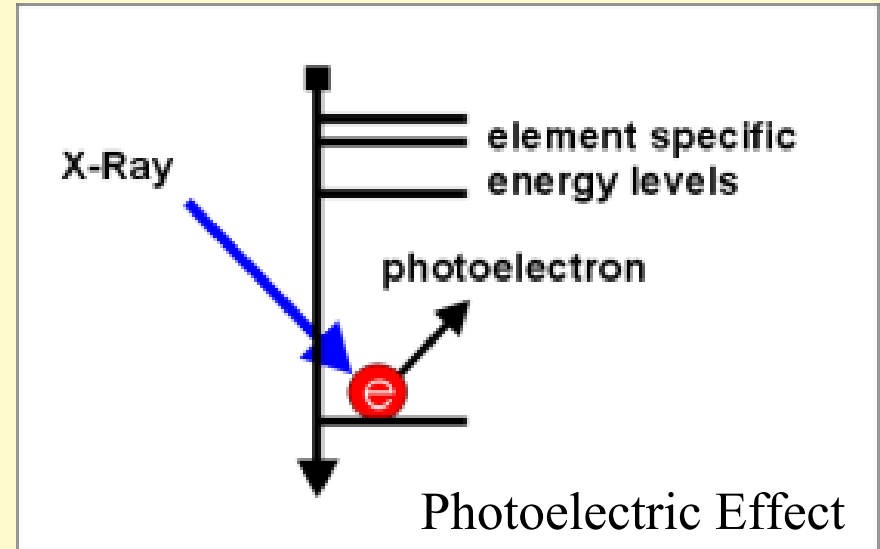
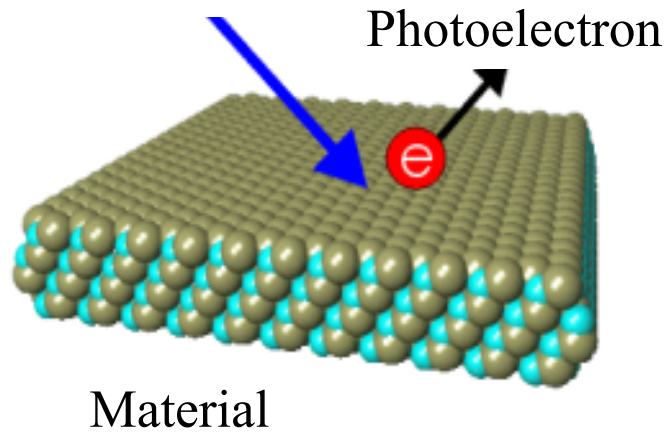

Surface Sensitivity is high.

XPS only probe a few monolayers of surface atoms.

XPS is not accurate for light atoms (F and below).

Quantitative estimation is not so accurate.

An Example of XPS Spectrum for Sm

Samarium Sm
Atomic Number 62

Handbook of X-ray Photoelectron Spectroscopy

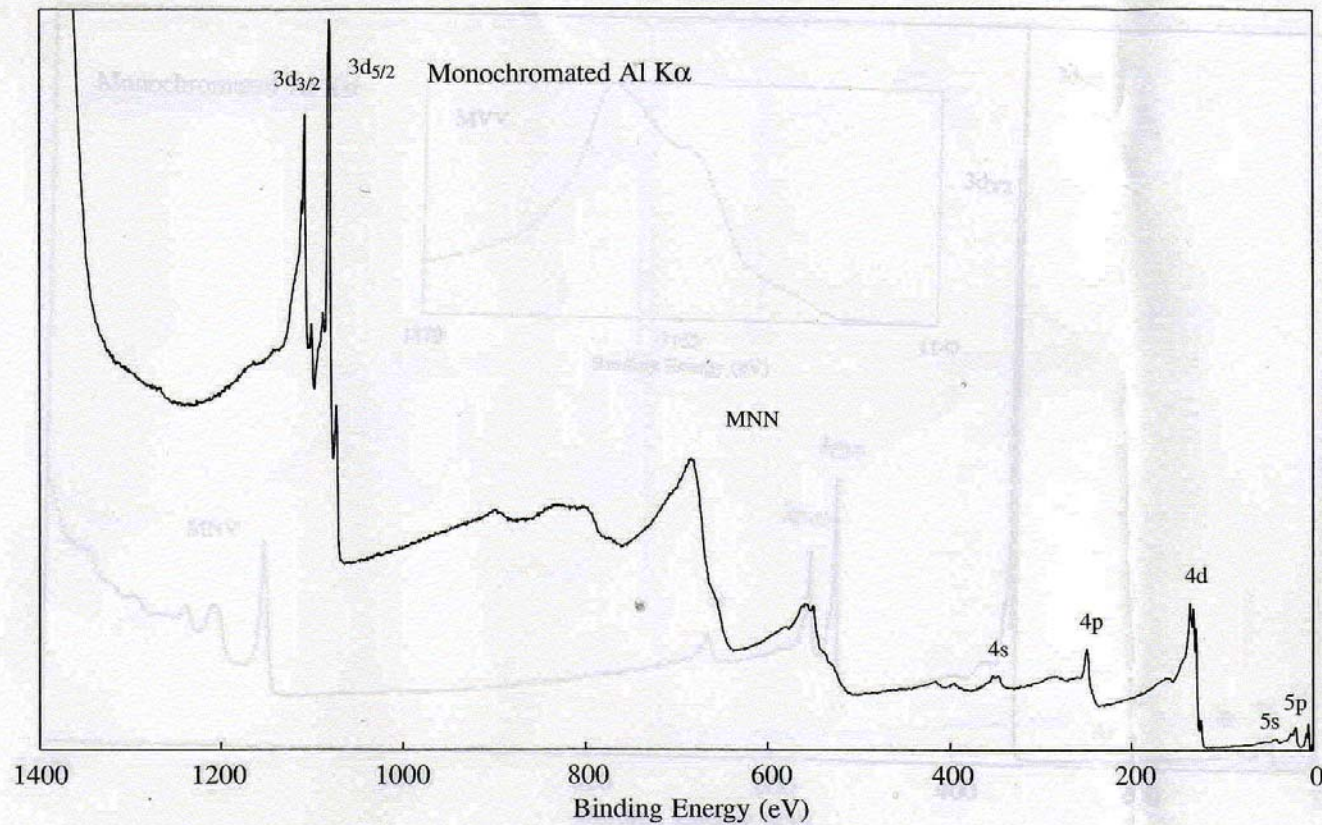

XPS Spectra for detected Sm

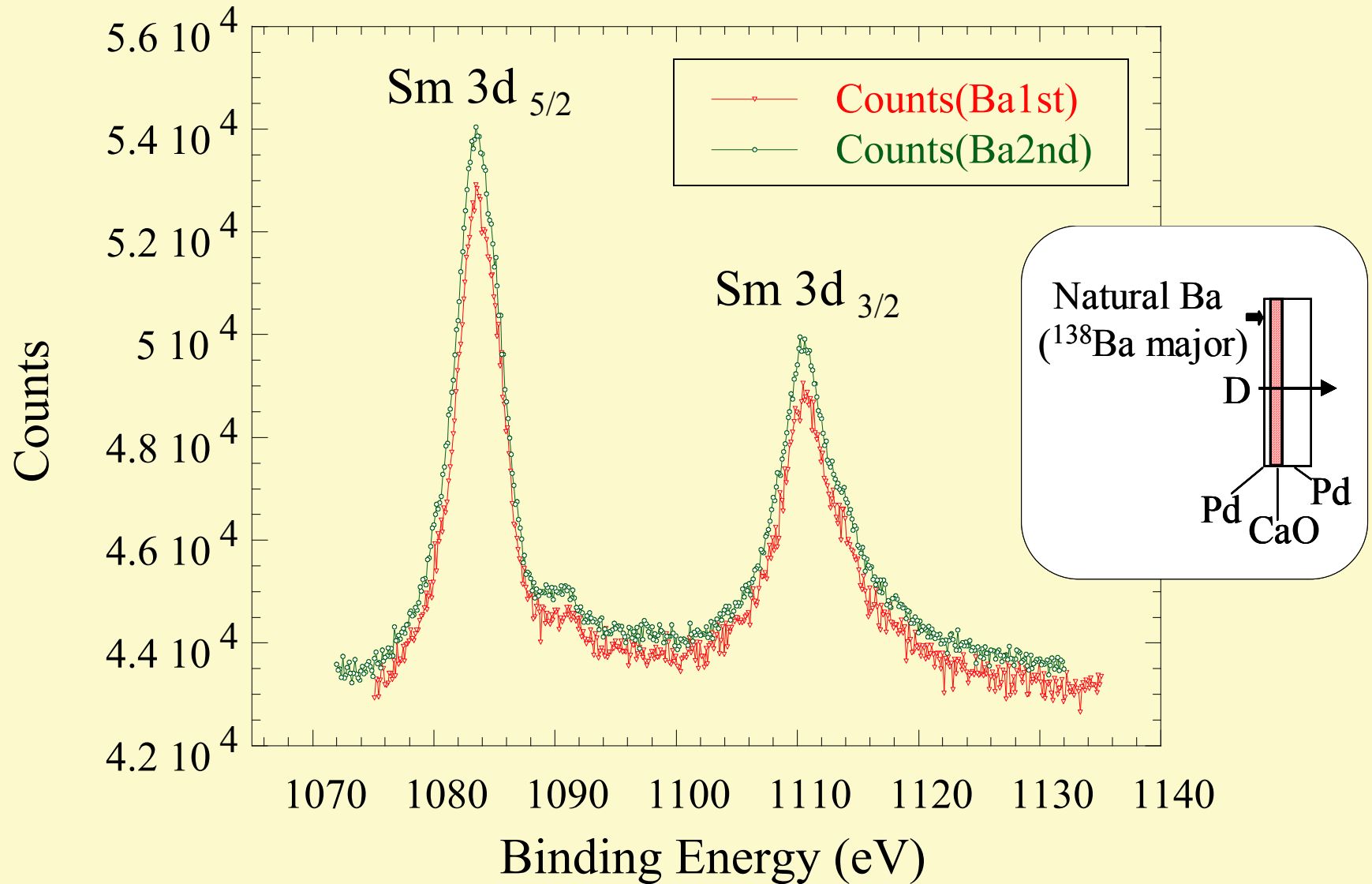

Full Spectrum

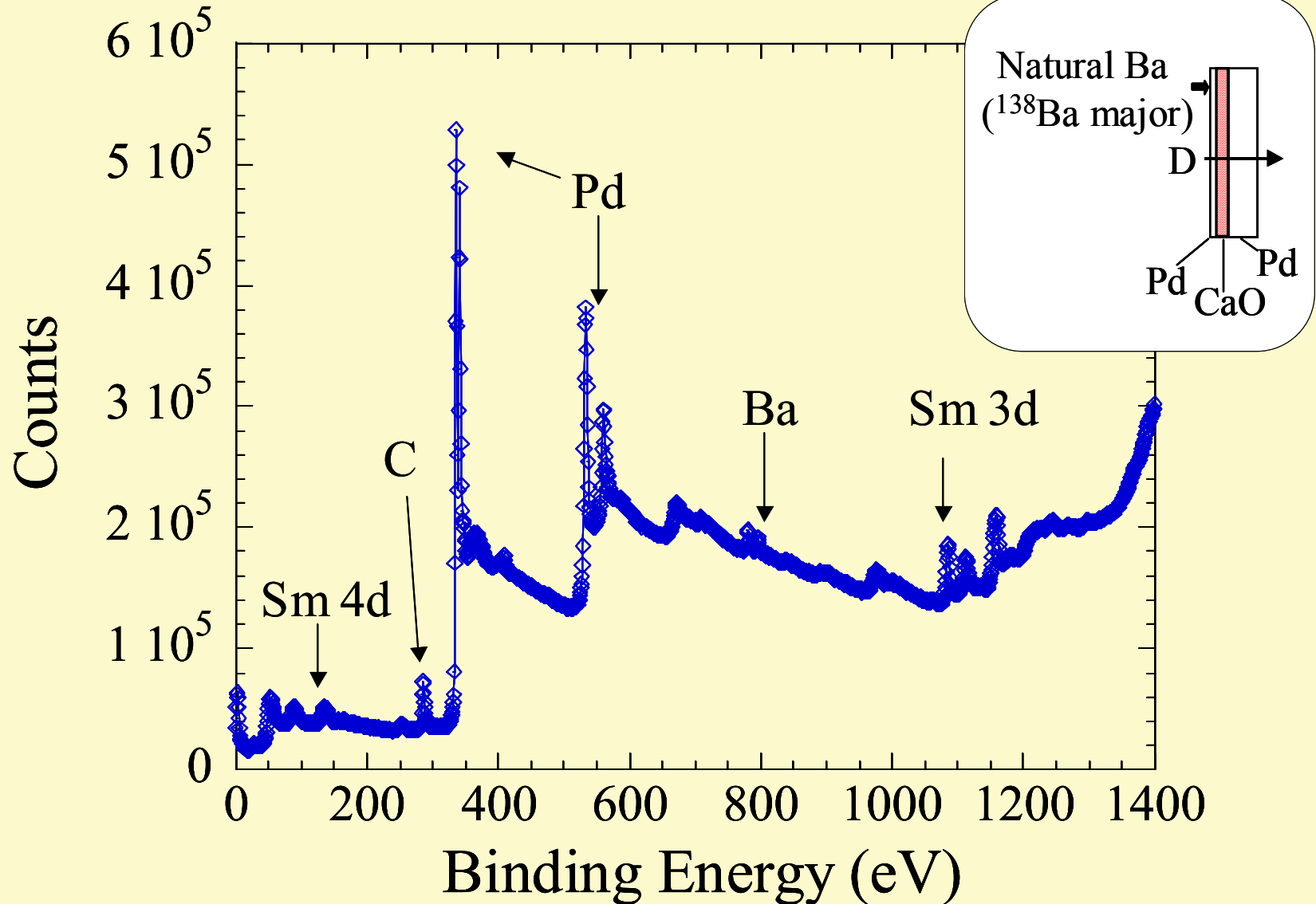

Sm Natural Abundance

^{144}Sm	^{147}Sm	^{148}Sm	^{149}Sm	^{150}Sm	^{152}Sm	^{154}Sm
3.2%	15.1%	11.3%	13.8%	7.5%	26.6%	22.5%

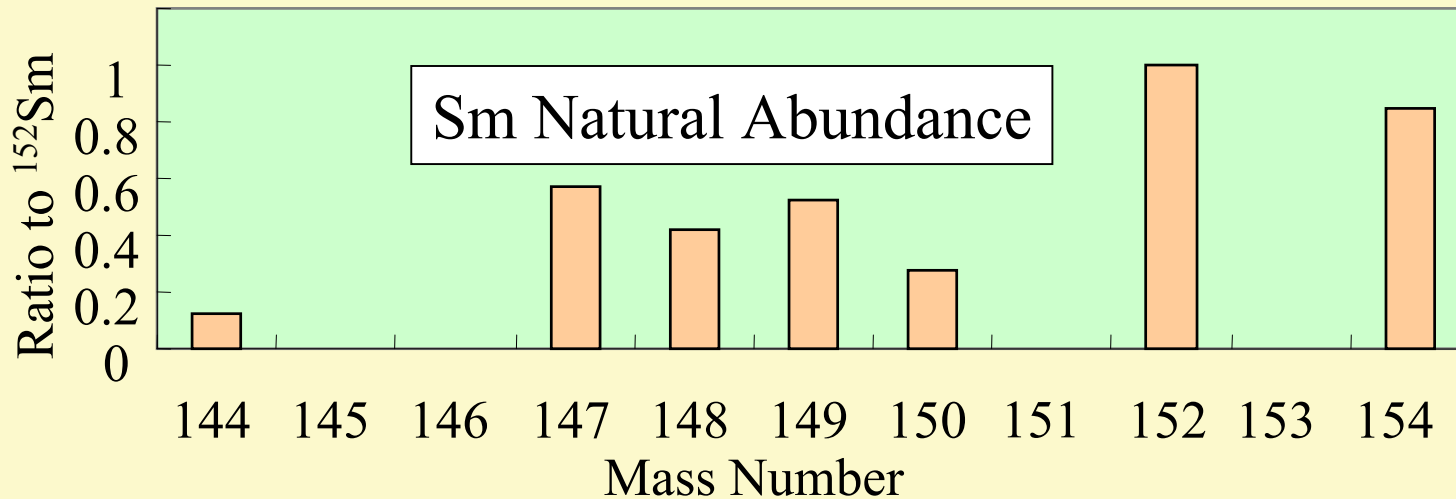

Fundamentals of SIMS

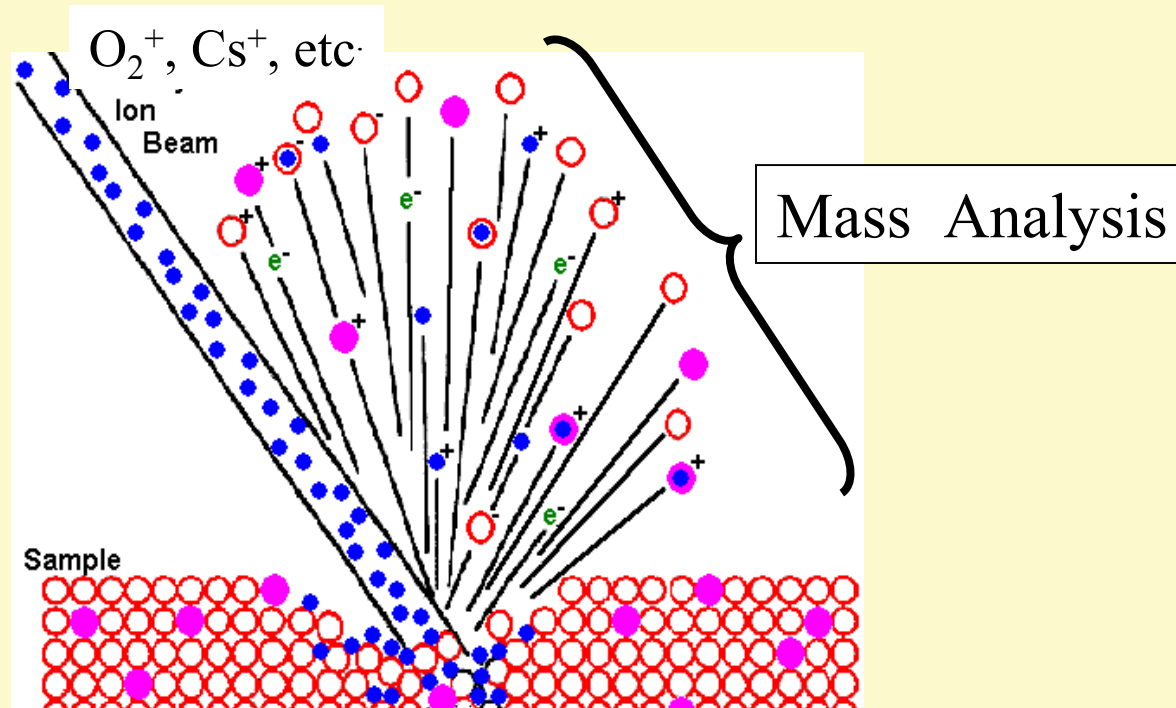

High Sensitivity. Local analysis is possible.

Sensitivity differs greatly depending on the elements of the sample and primary ions.

Effects of molecular ions should be considered.

SIMS Spectra for Given and Detected Elements

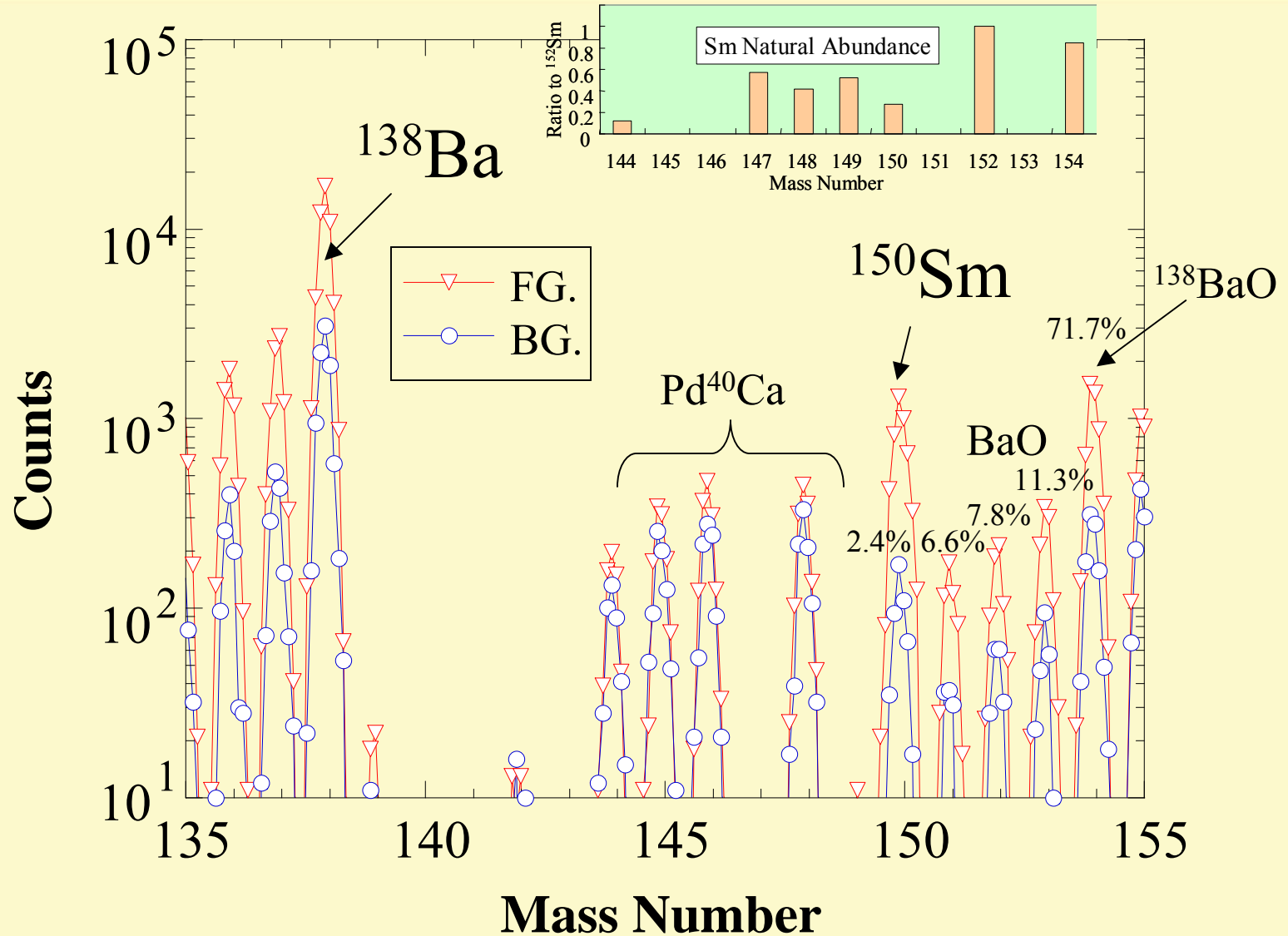

Examination of Molecular Ions

Pd	Pd ⁴⁰ Ca
102(1%)	142
104 (11%)	144
105 (22%)	145
106 (27%)	146
108 (26%)	148
110 (12%)	150

Ba	Ba ¹⁶ O
130(0.1%)	146
132(0.1%)	148
134(2.4%)	150
135(6.6%)	151
136(7.8%)	152
137(11.3%)	153
138(71.7%)	154

No Molecular Ions for 149.

¹¹⁰Pd(12%)Ca and ¹³⁴Ba(2.4%)O for mass 150, however their effects should be lower than ¹⁰⁶Pd(27%)Ca and ¹³⁸Ba(71.7%)O

Transmutation of Natural Ba into Sm

- XPS analysis showed Sm spectra.
- SIMS analysis showed the increase of mass 150.
- Natural Sm isotopic distribution did not match with SIMS mass data.
- These facts strongly suggests that ^{150}Sm exists on the Pd complex after D_2 gas permeation.

Transmutation of Ba into Sm; mass 137 Enriched Ba

MITSUBISHI HEAVY INDUSTRIES, LTD.
ADVANCED TECHNOLOGY RESEARCH CENTER

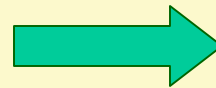
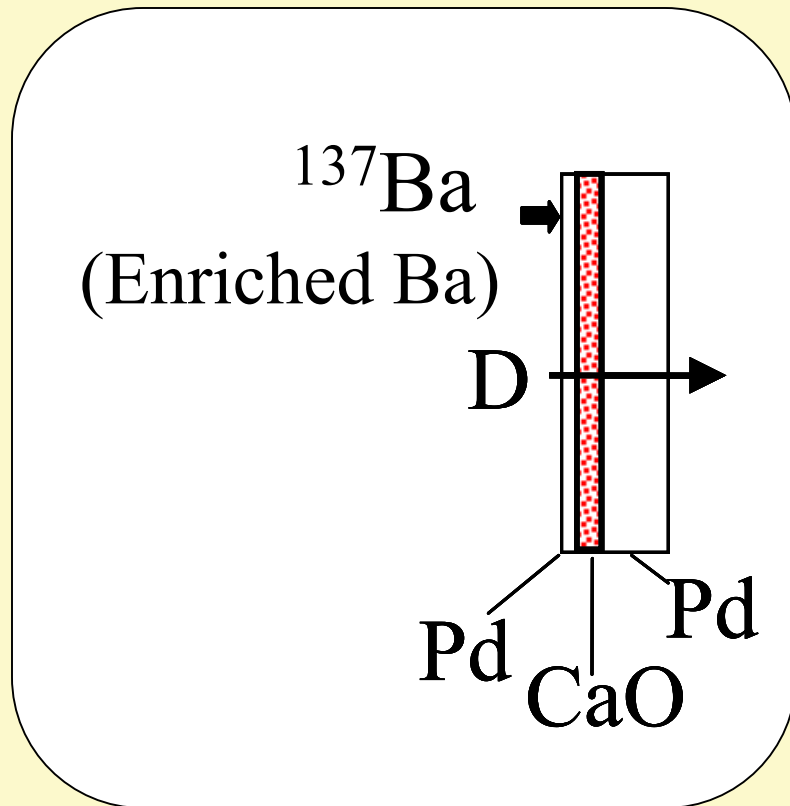

^{149}Sm were possibly
detected after D
permeation
on the Pd complex

SIMS Spectra for ^{137}Ba

#1 Experiment

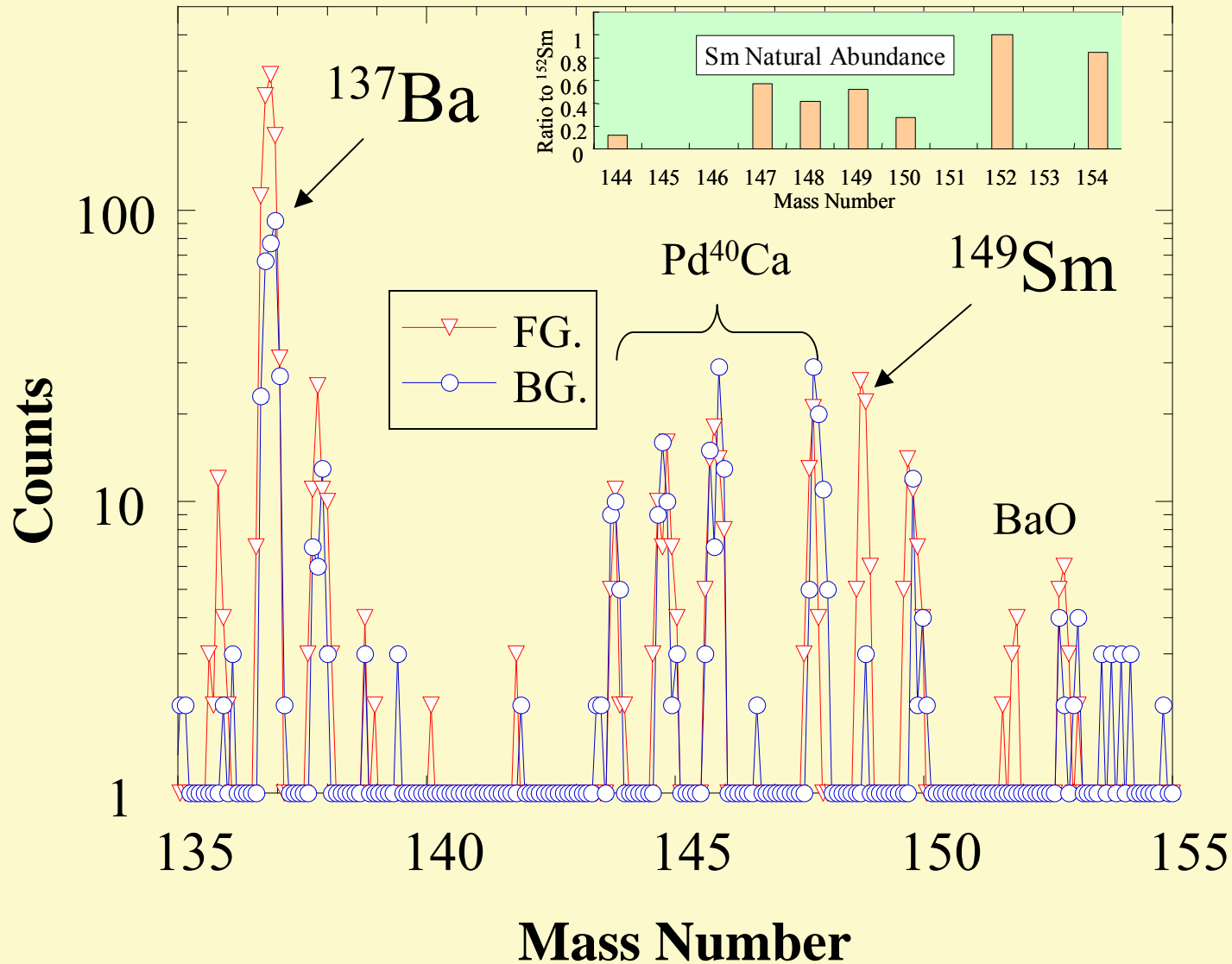

SIMS Spectra for ^{137}Ba

#2 Experiment

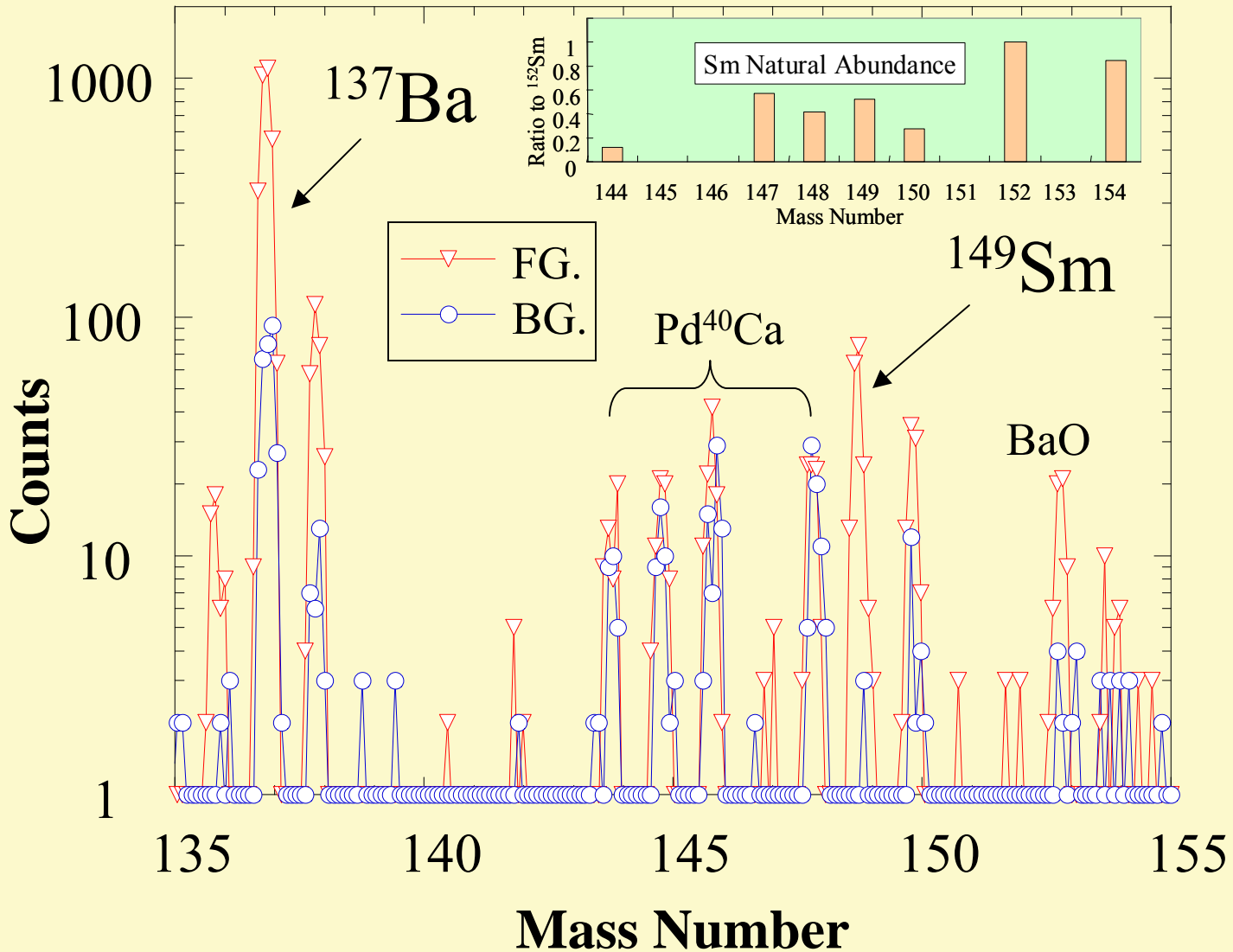

Transmutation of ^{137}Ba into Sm

- SIMS analysis showed the increase of mass 149.
- Natural Sm isotopic distribution did not match with SIMS mass data.
- XPS analysis showed very weak Sm spectra. Now we are trying to obtain clear XPS signals.
- These facts suggests that ^{149}Sm exists on the Pd complex if we consider that Sm spectra were obtained by XPS using natural Ba.

Mass Correlation between Given and Detected Elements

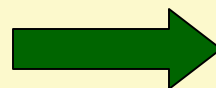
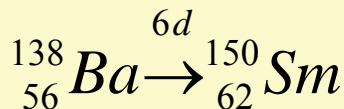
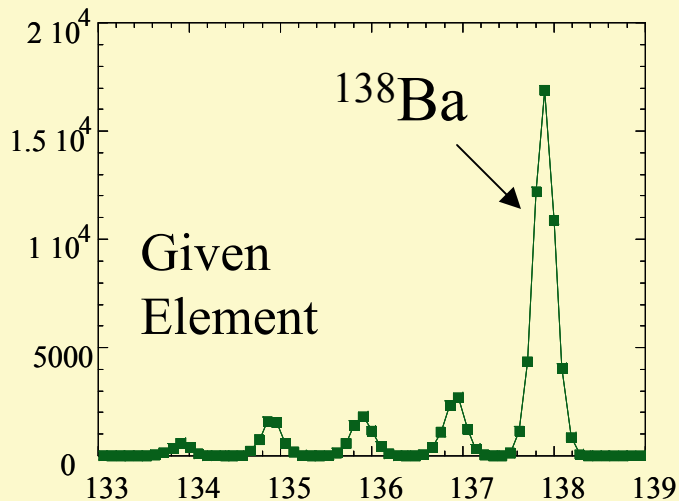

M +12
Z +6

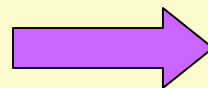
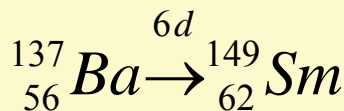
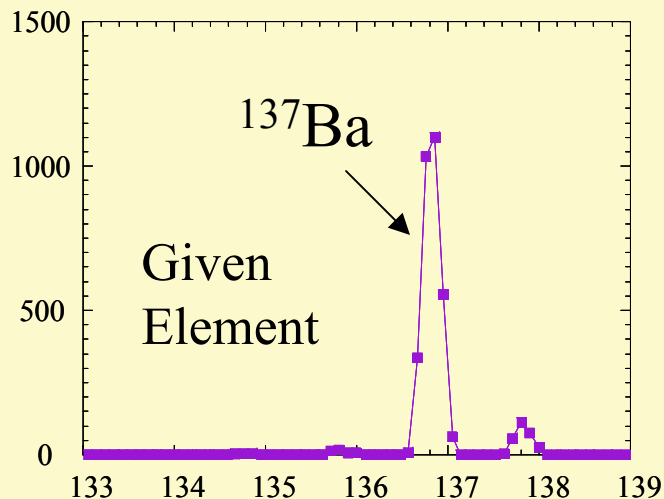
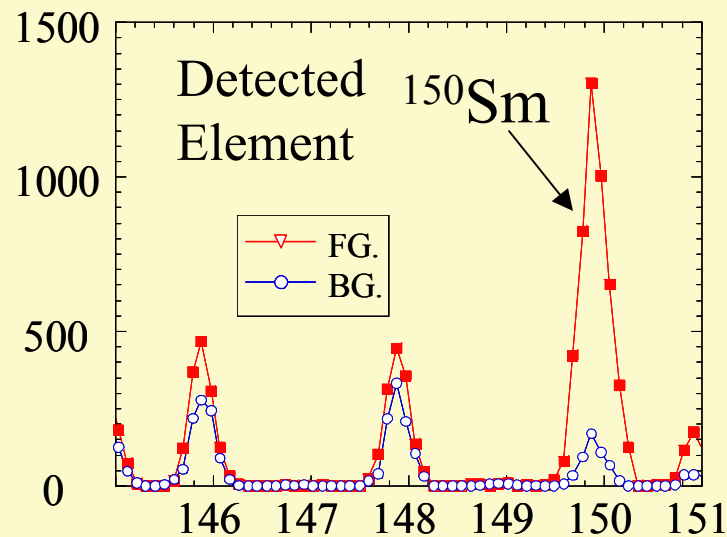

M +12
Z +6

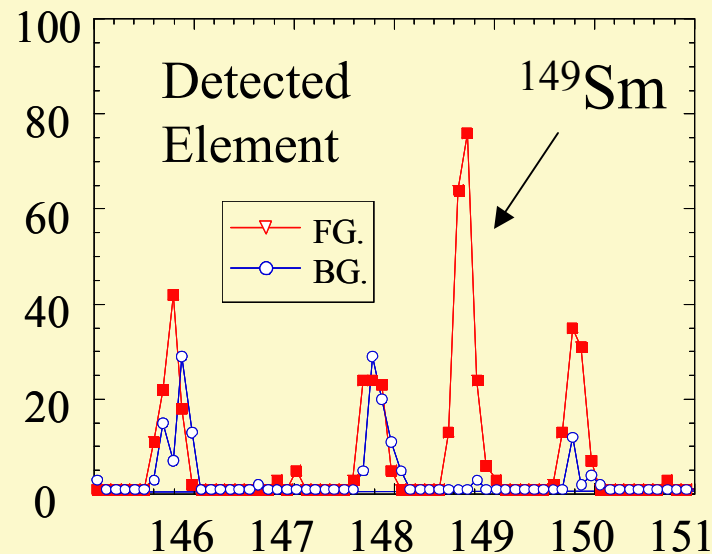

The Aim of Ba Transmutation Experiments

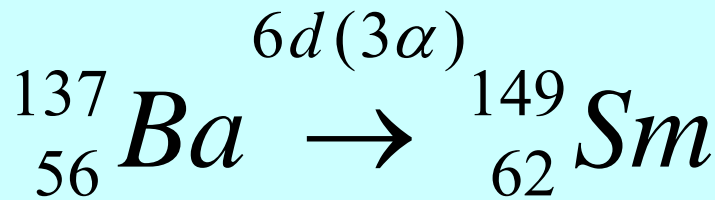

Experimental Results

${}^{149}\text{Sm}$ is a
Mossbauer
Isotope

Excitation Energy: 22.5keV

If we measure the Mossbauer effect of ${}^{149}\text{Sm}$, we will obtain a clear evidence of generation of ${}^{149}\text{Sm}$. And the information on the ultra fine structure relating to the electronic state and phonon of the generated ${}^{149}\text{Sm}$ will be obtain.

Recent Results; Part 2

**Pr Confirmation by XRF
and Experiments for
in-situ Measurement at SPring-8**

Identification of Pr by X-ray Fluorescence(XRF)

MITSUBISHI HEAVY INDUSTRIES, LTD.
ADVANCED TECHNOLOGY RESEARCH CENTER

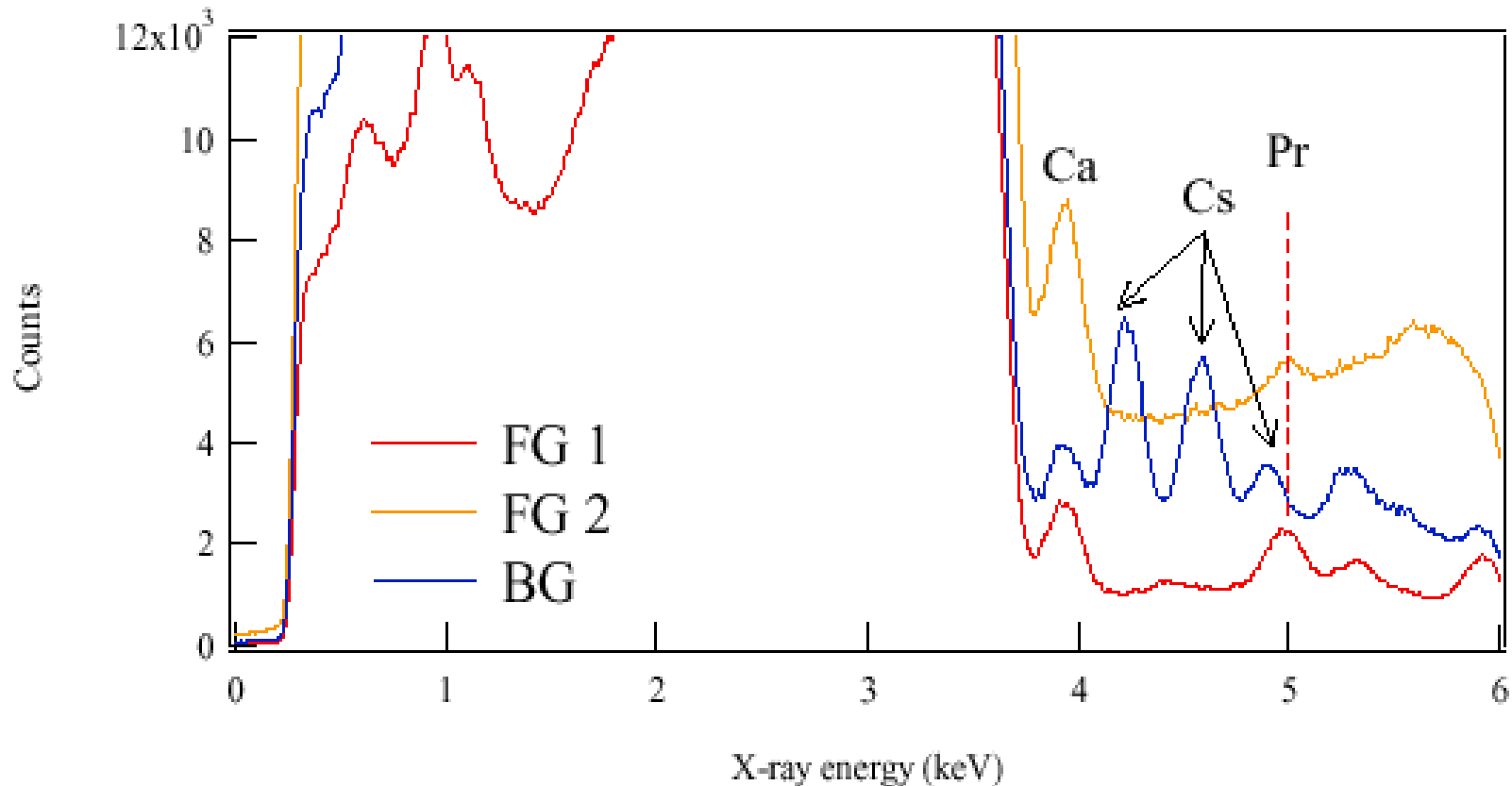

Detection of Pr using SOR X-ray at Spring-8, Harima, Japan
(FG1,FG2:Signals from Samples after D2 Permeation
BG:Signals from the sample before Permeation)

Fundamentals of XRF

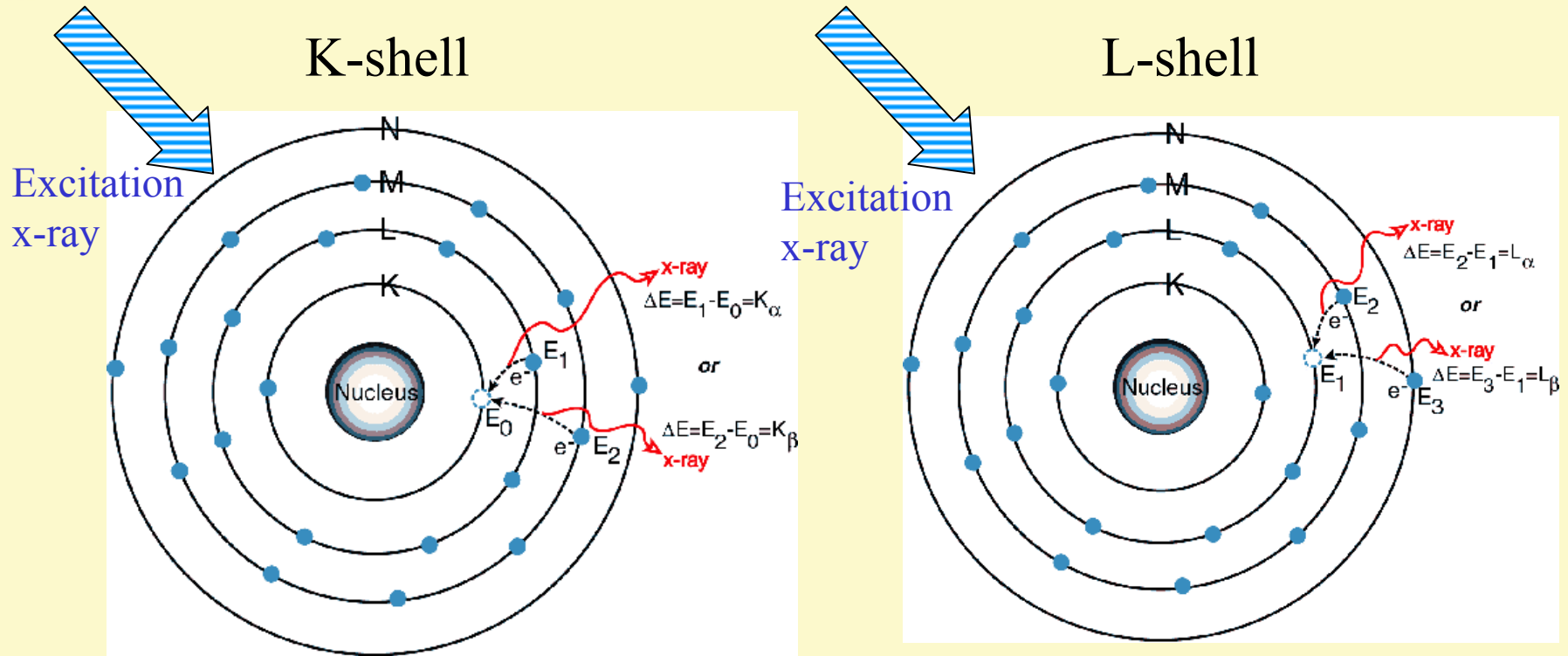

Bulk analysis method(micron order)
Surface sensitivity is low.
Established method.

Experimental Set-up for *in-situ* Measurement located at SPring-8

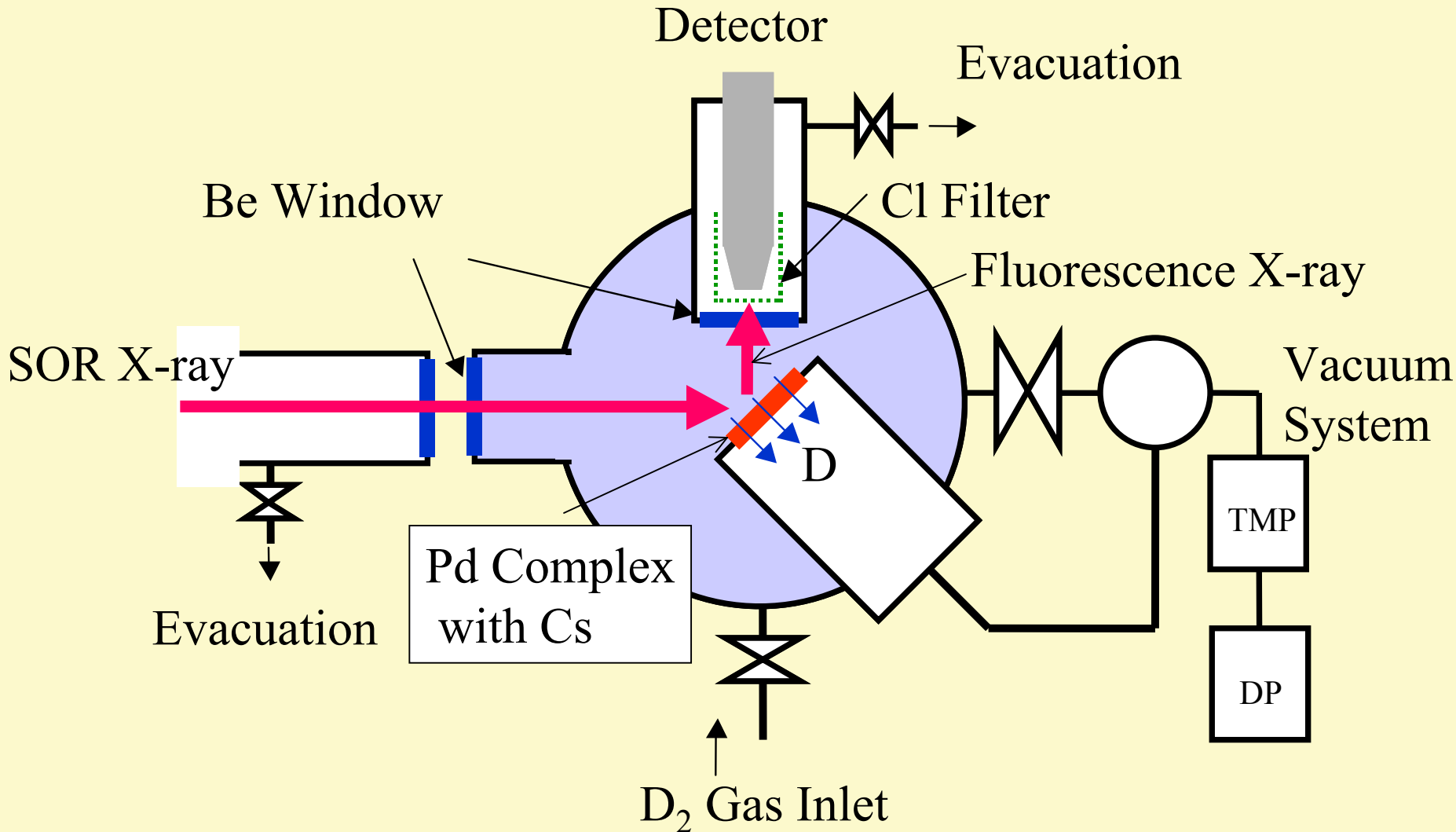

Photograph of the Experimental Set-up

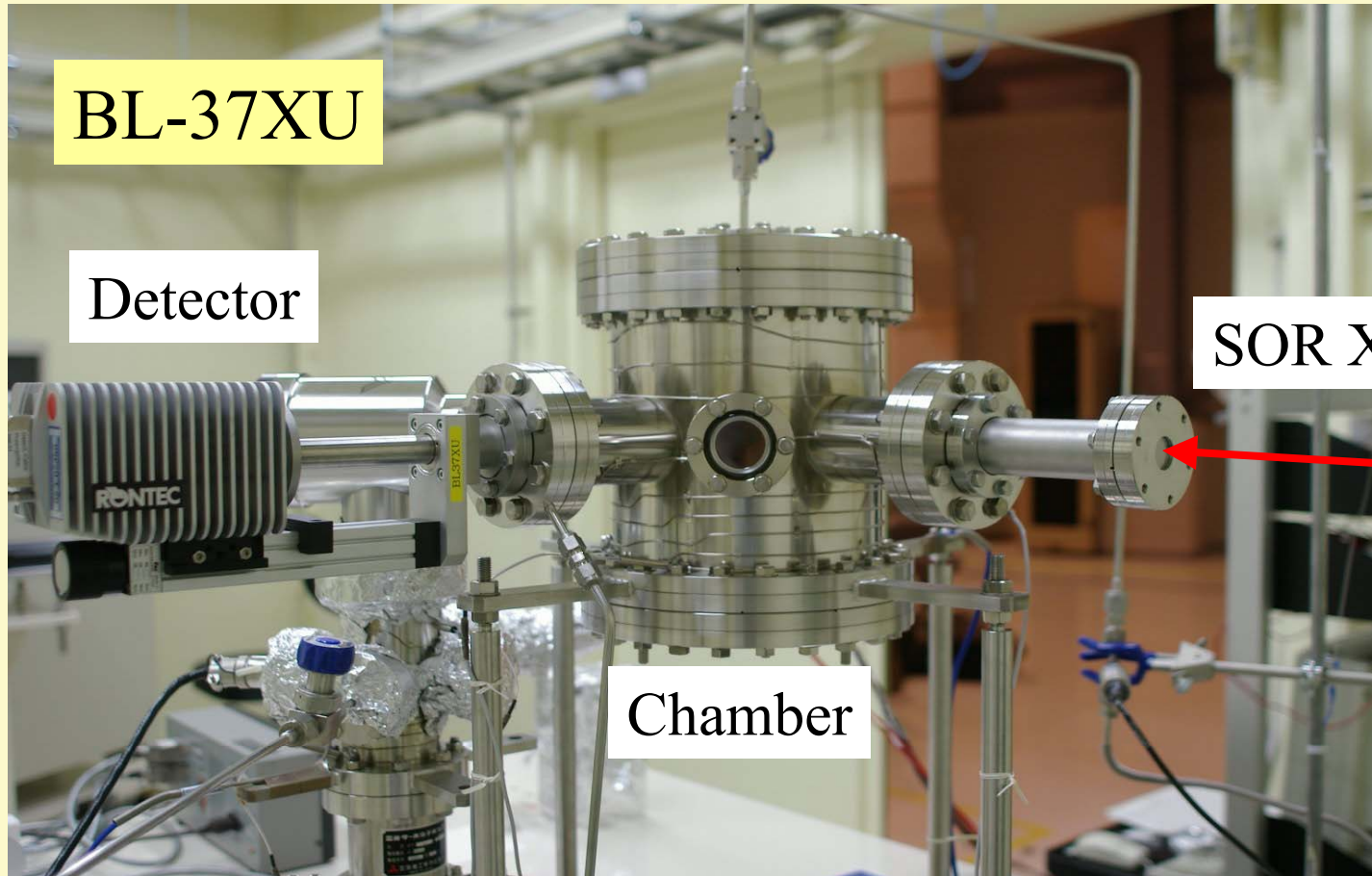

BL-37XU

Detector

SOR X-ray

Chamber

An Example of Pr Detection by the Experiments at SPring-8

MITSUBISHI HEAVY INDUSTRIES, LTD.
ADVANCED TECHNOLOGY RESEARCH CENTER

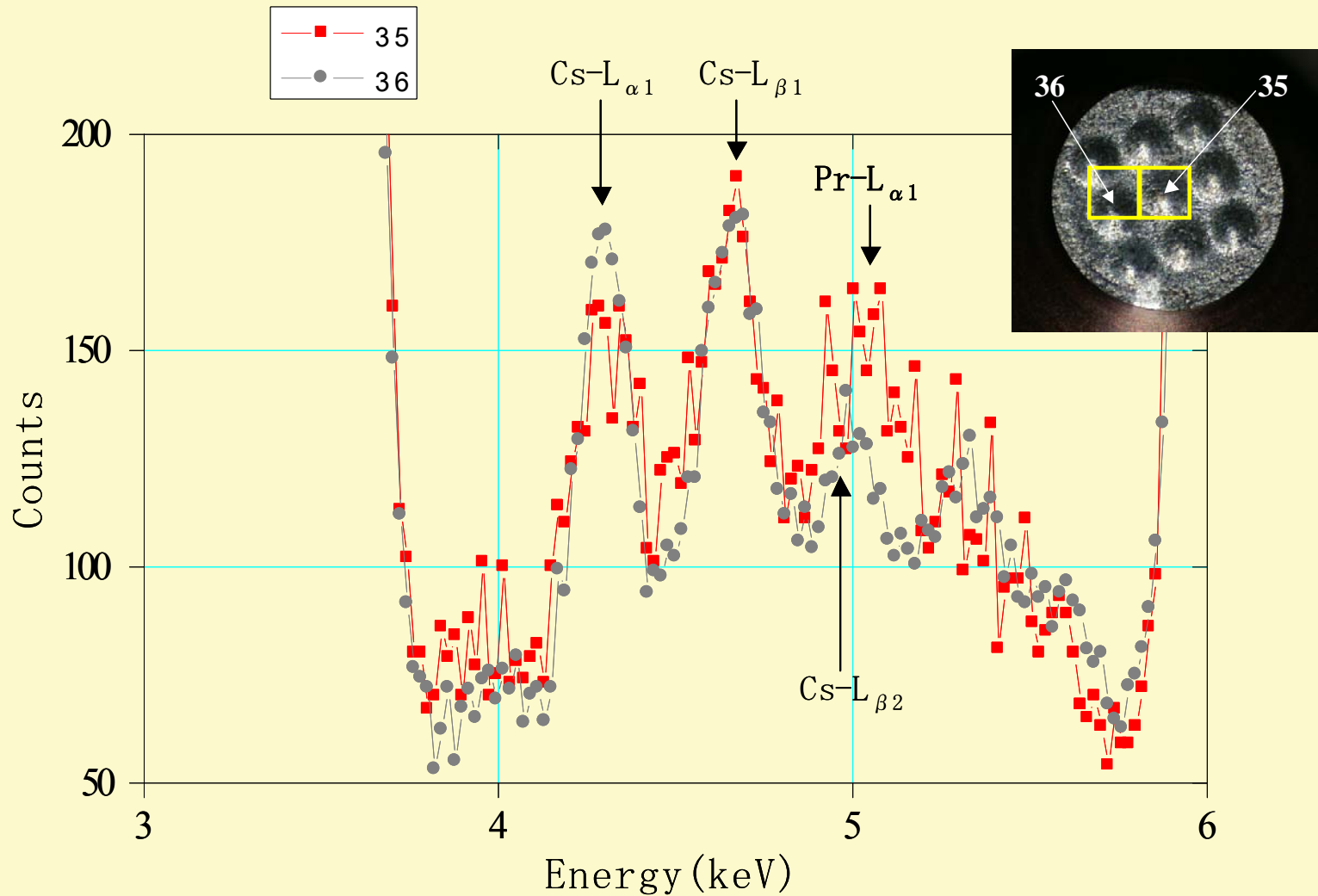

Recent Results; Part 3

Measurement and Experiments relating to the role of CaO

TEM Photograph of the Pd Complex

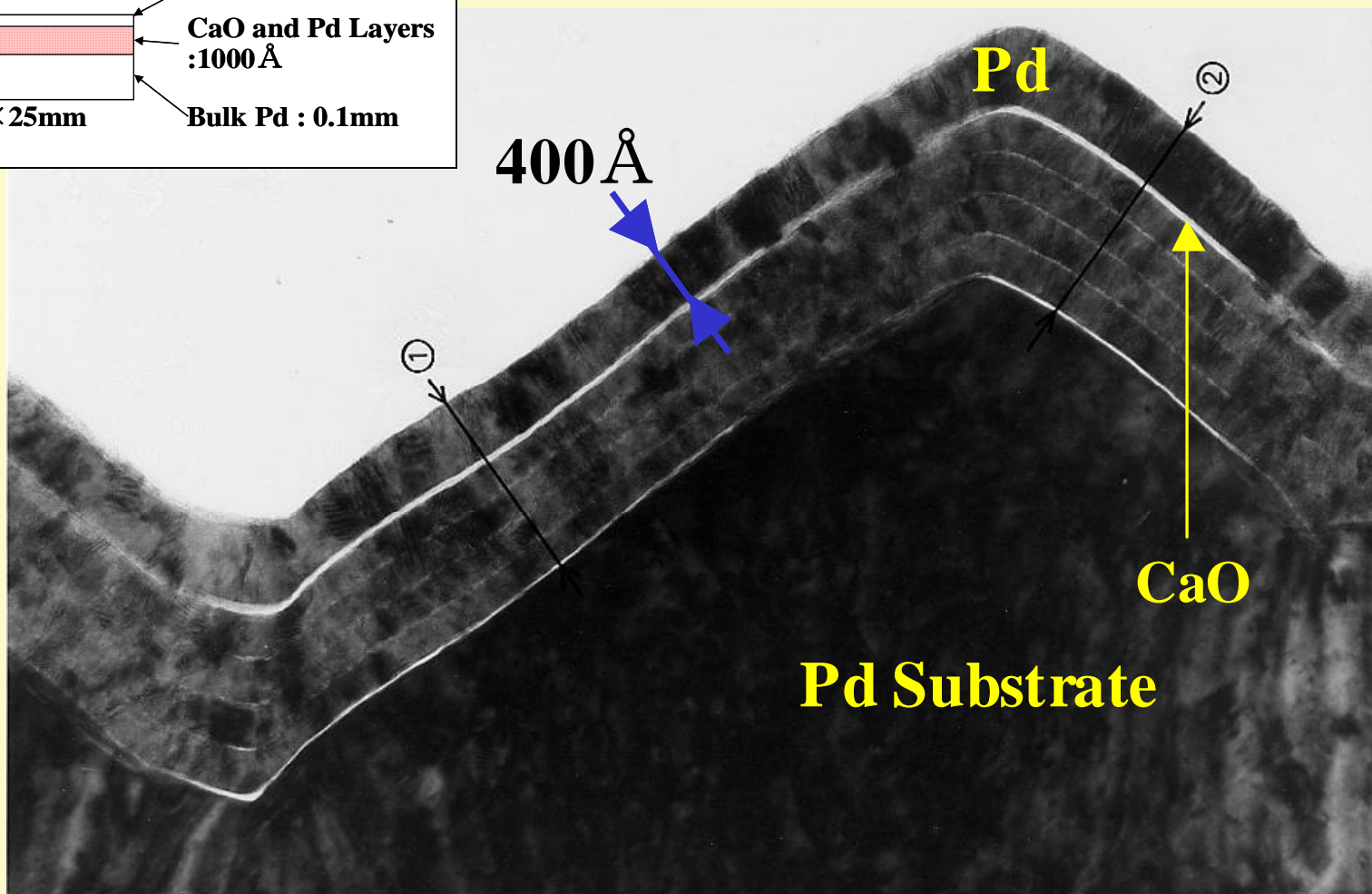
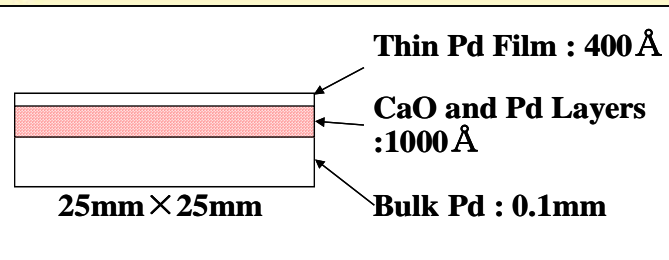

Depth Profile of Cs and Pr by TOF-SIMS

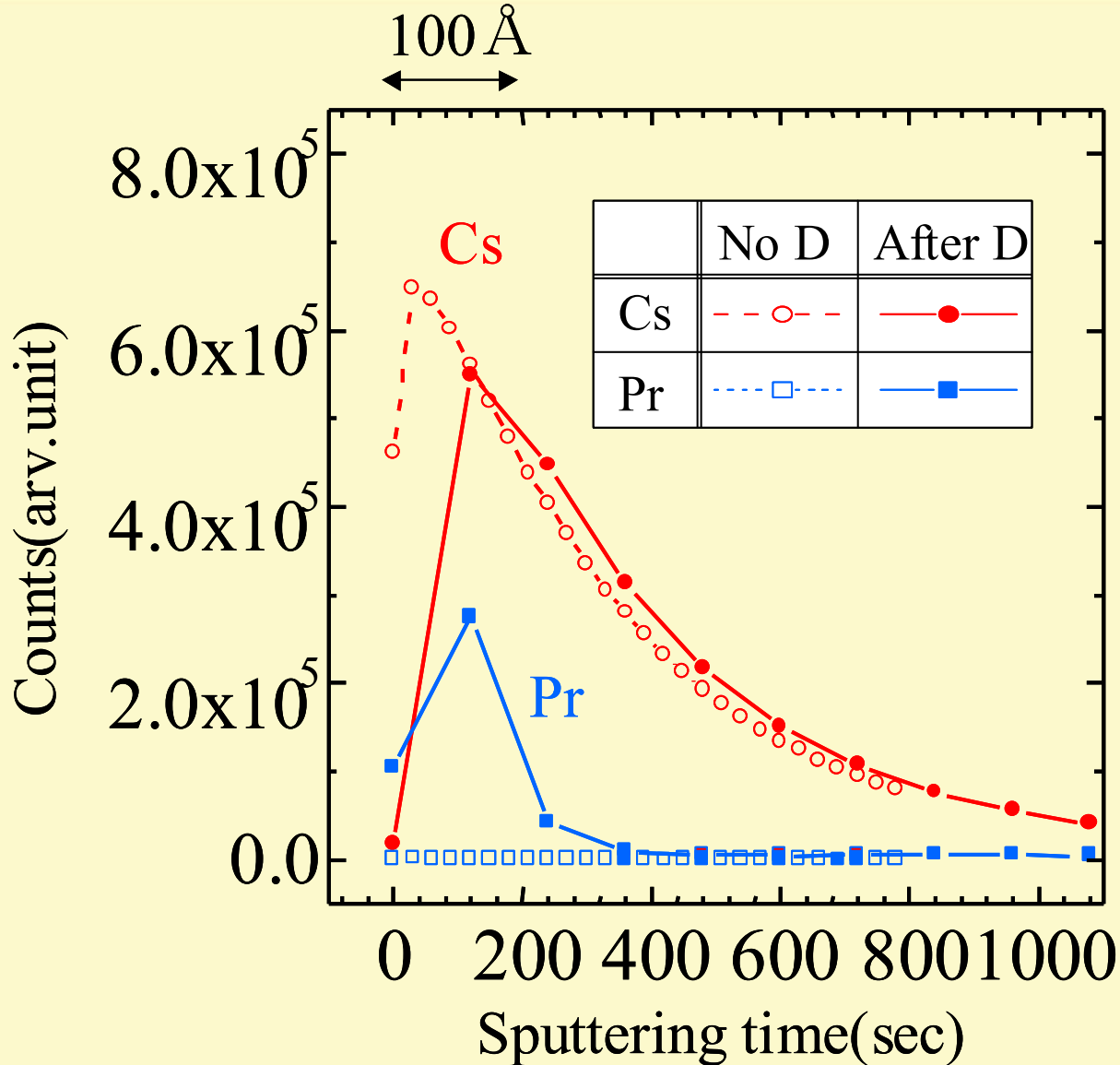

Depth Profile of Cs and Pr by XPS(1)

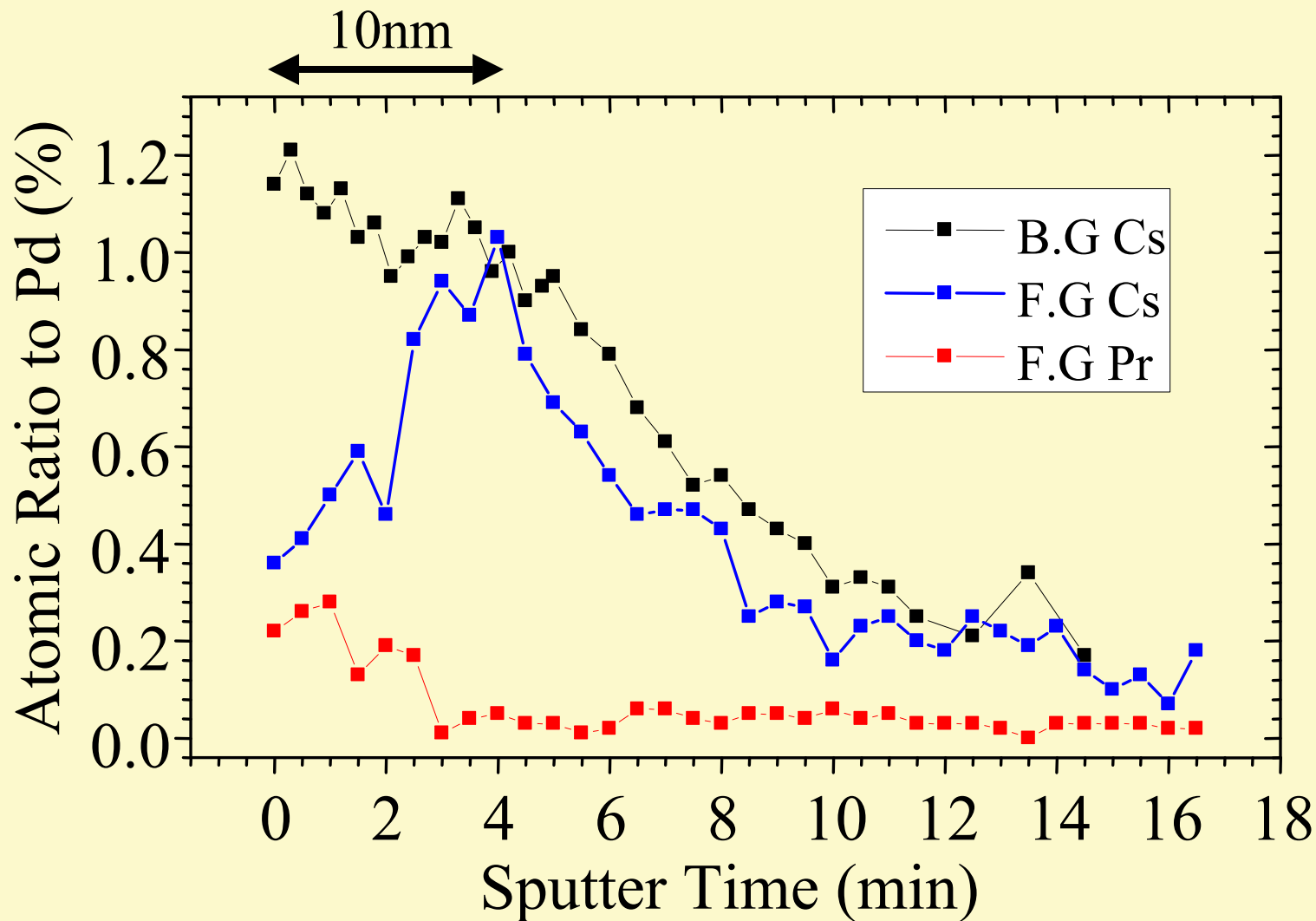

D⁺ Ion Bombardment Experiment Performed at Tohoku Univ.

IBS BWHI HEAVY INDUSTRIES, LTD.
ADVANCED TECHNOLOGY RESEARCH CENTER

D⁺ Ion beam bombardment
on metal target

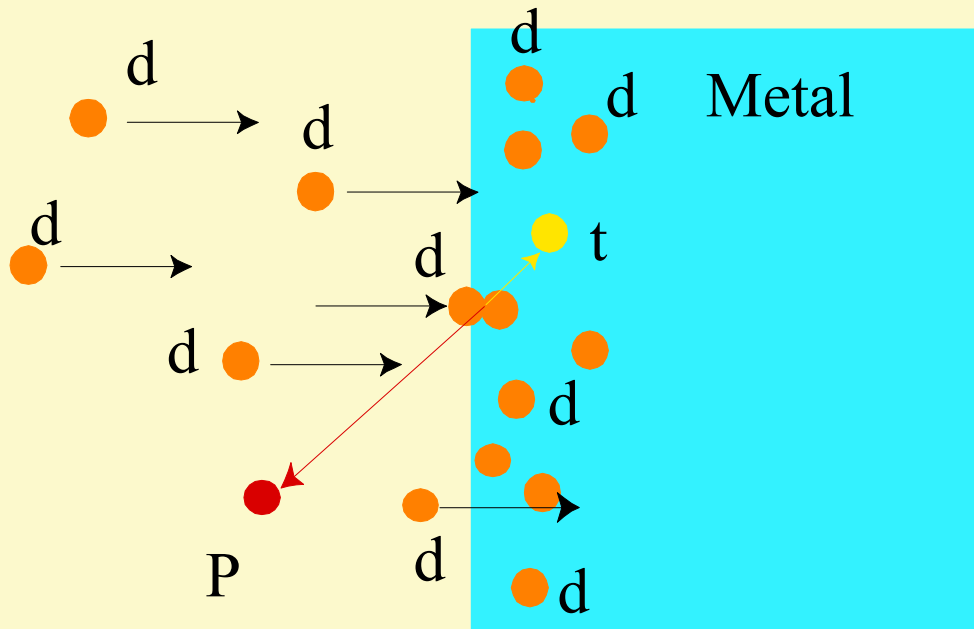

Experimental Apparatus

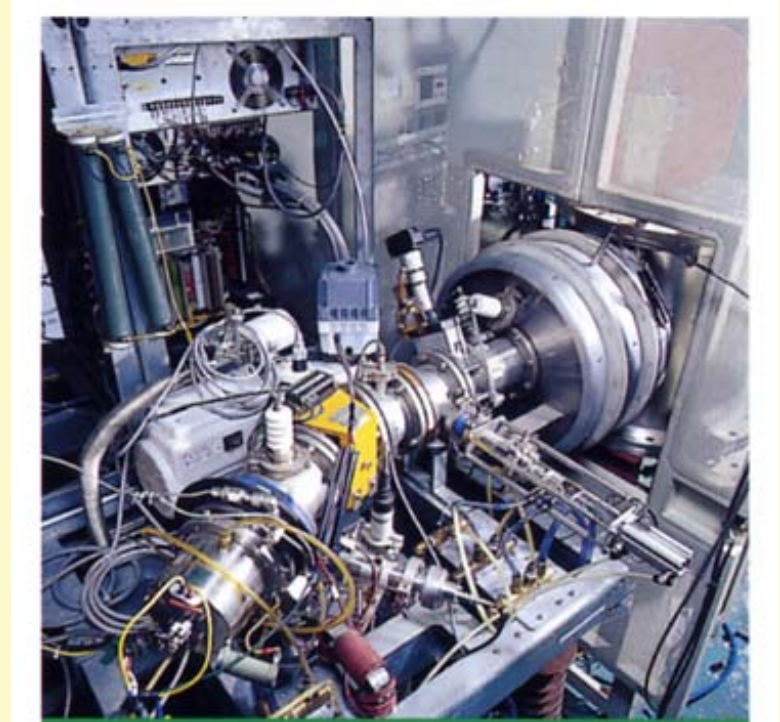

Deuterium Density measured by D^+ Ion Bombardment Experiment

MITSUBISHI HEAVY INDUSTRIES, LTD.
ADVANCED TECHNOLOGY RESEARCH CENTER

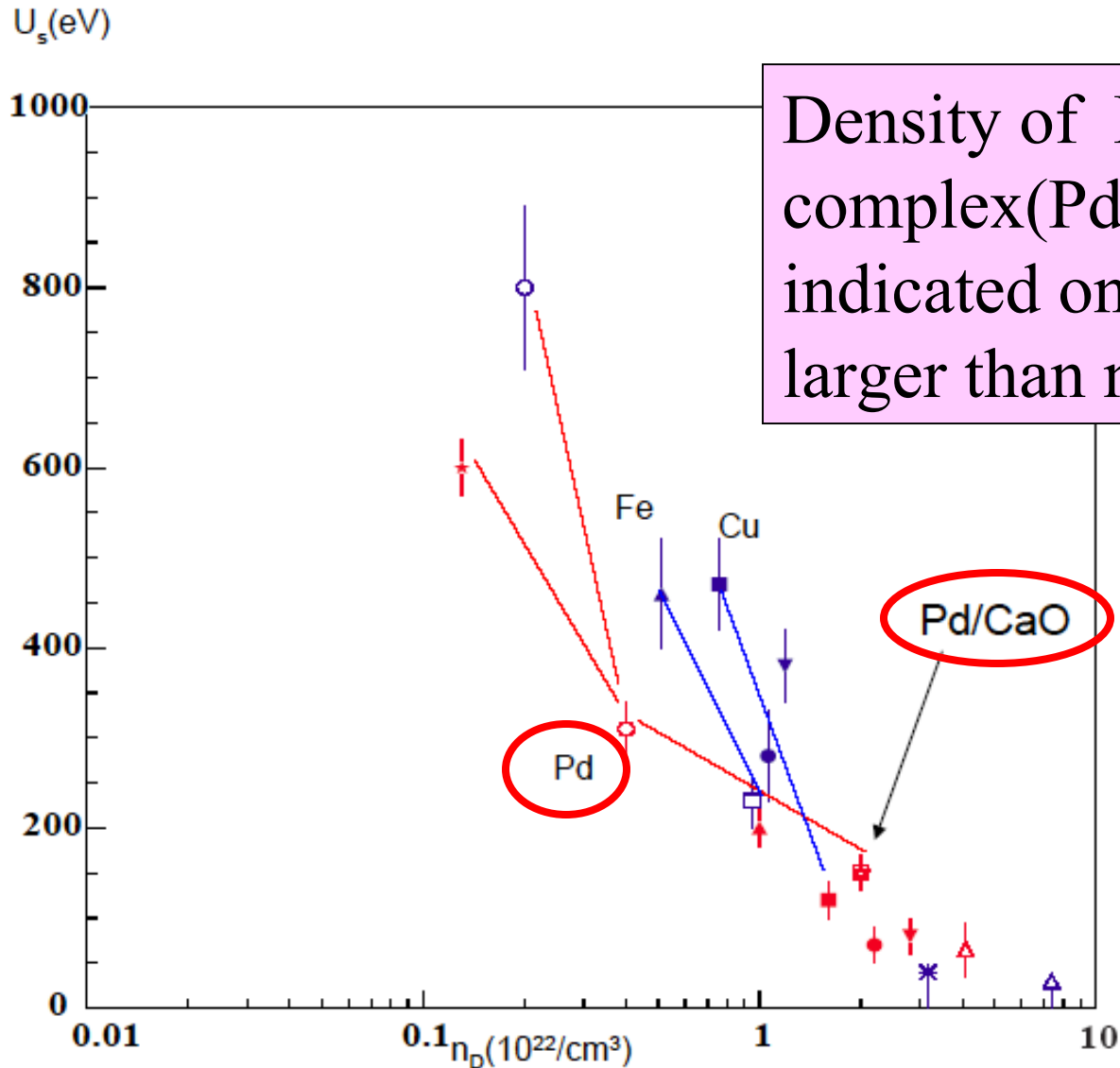

Density of Pd complex(Pd/CaO) indicated one order larger than normal Pd

MgO cannot work instead of CaO

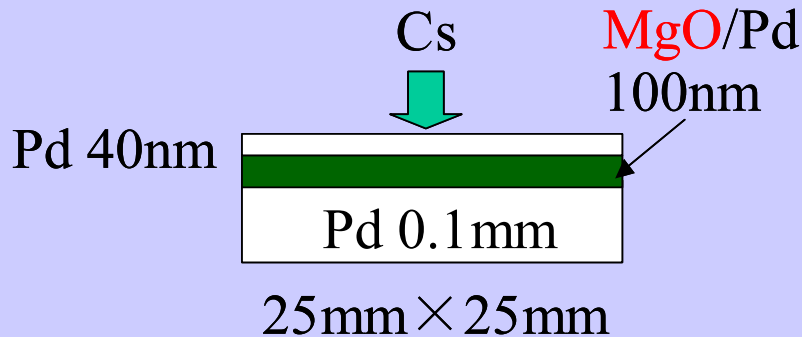

No Pr; Two cases out of two experiments.

ICP-MS measurements show no Pr(<0.01ng).

D₂ gas Flow rate enough(2-3sccm)

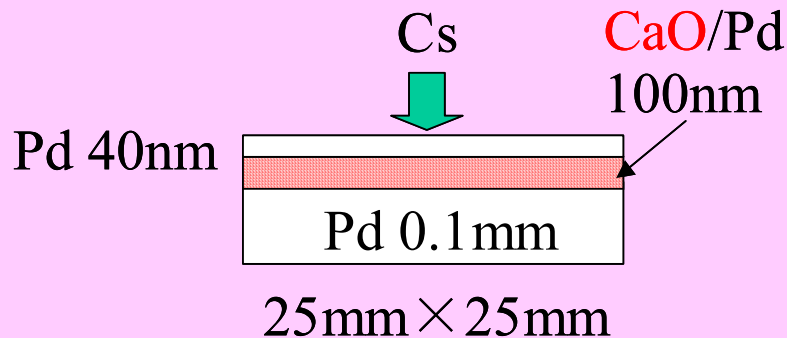

Almost every time Pr were detected.

More than 60 cases.

Consideration on the Role of CaO

- Increase of Deuterium Density ?
- Modify the Electronic State of Surface Pd?

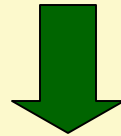

Depth Profile Measurement of D
By a Resonance Nuclear Reaction

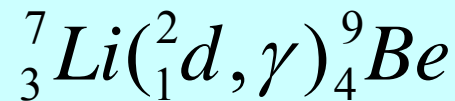

Conjecture on D distribution in the Pd Complex

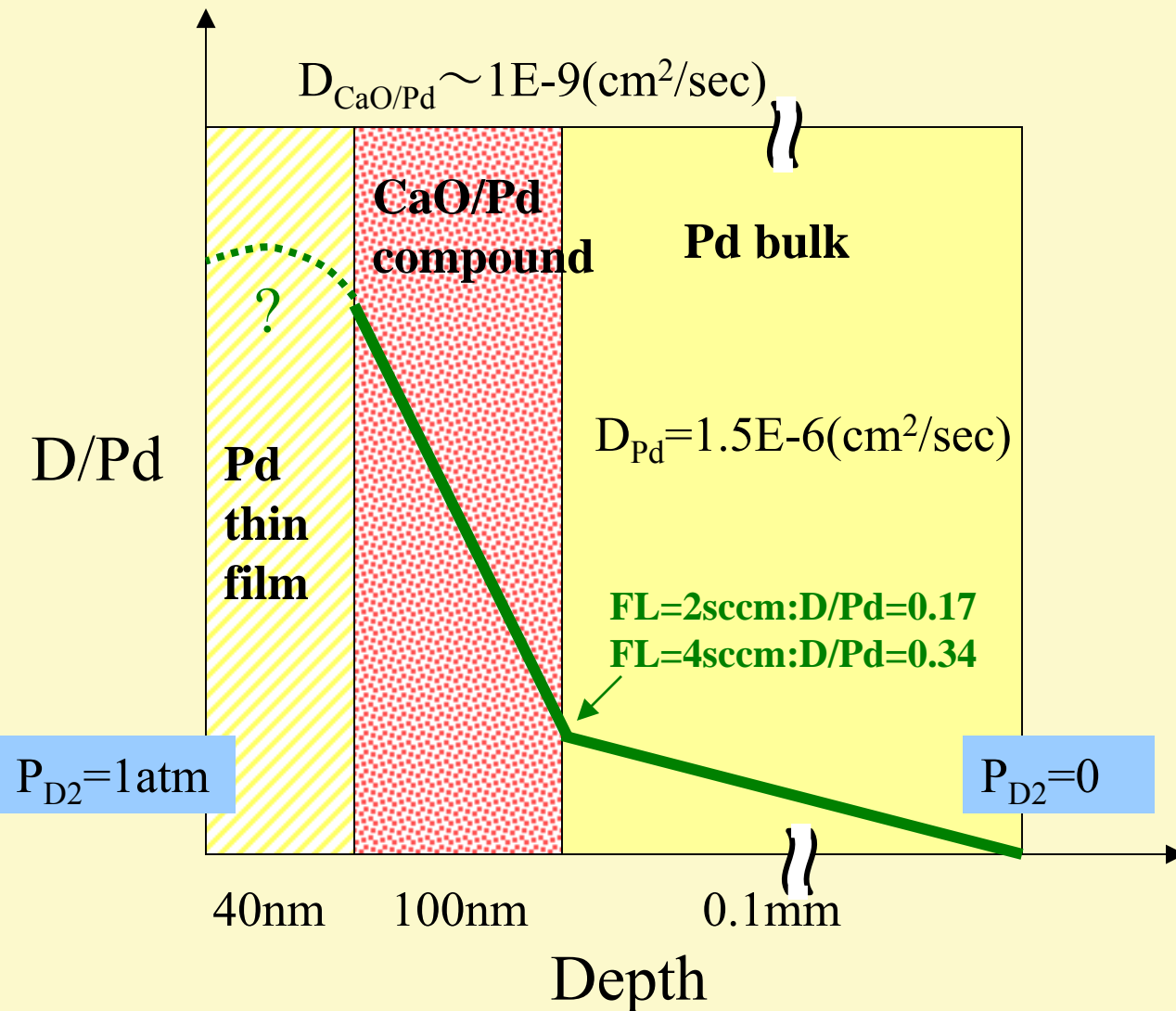

$$\frac{\partial C}{\partial t} = D \frac{\partial^2 C}{\partial x^2} \quad \frac{\partial}{\partial t} = 0$$

$$Q = A \cdot J = -A \cdot D \frac{\partial C}{\partial x}$$

$$-A \cdot D_{CaO/Pd} \cdot \frac{\partial C}{\partial x} \Big|_{CaO/Pd}$$

$$= -A \cdot D_{Pd} \cdot \frac{\partial C}{\partial x} \Big|_{Pd}$$

$$D_{CaO/Pd} \leq D_{Pd}$$



$$\frac{\partial C}{\partial x} \Big|_{CaO/Pd} \geq \frac{\partial C}{\partial x} \Big|_{Pd}$$

Depth Profile Measurement of D by Resonance Nuclear Reaction

	Reaction	Resonance Energy (MeV)	Width (keV)	Gamma Energy (MeV)	Cross section (mbarn)
H	$^1\text{H}(^{15}\text{N}, \alpha\gamma)^{12}\text{C}$	6.385/13.65	1.8/25.4	4.43	1650/1050
D	$^2\text{d}(^7\text{Li}, \gamma)^9\text{Be}$	1.260	1.365	15.5-17	20-200

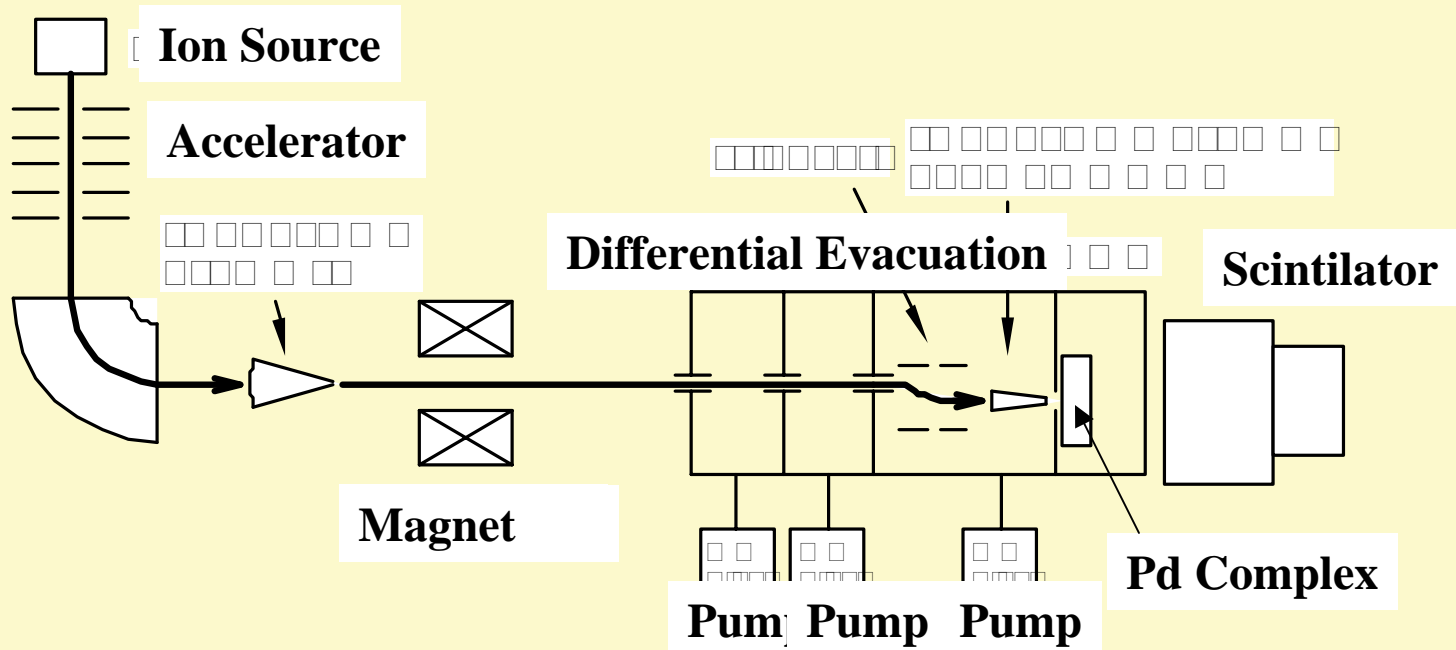

Concluding Remarks

- 1. Transmutations of Ba into Sm were observed both for the case of giving natural Ba on Pd complex samples and for the case of giving mass 137 enriched Ba.
It means that we obtained mass distribution of Sm depending on given isotopic distribution of Ba by our experimental method.**
- 2. One of our experimental apparatus was carried to SPring-8 for the purpose of in-situ measurement and we obtained some Pr signals by the X-ray Fluorescence method.**
- 3. According to a D^+ ion beam bombardment experiment performed at Tohoku University, deuterium density of our Pd complex indicated one order larger than normal Pd.**