



US 20110005506A1

(19) **United States**

(12) **Patent Application Publication**
Rossi

(10) **Pub. No.: US 2011/0005506 A1**

(43) **Pub. Date: Jan. 13, 2011**

(54) **METHOD AND APPARATUS FOR CARRYING OUT NICKEL AND HYDROGEN EXOTHERMAL REACTION**

(30) **Foreign Application Priority Data**

Apr. 9, 2008 (IT) MI2008A 000629

(76) Inventor: **Andrea Rossi, Roma (IT)**

Publication Classification

Correspondence Address:
HEDMAN & COSTIGAN, P.C.
1230 AVENUE OF THE AMERICAS, 7th floor
NEW YORK, NY 10020 (US)

(51) **Int. Cl.**
F24J 1/00 (2006.01)

(52) **U.S. Cl.** **126/263.01**

(57) **ABSTRACT**

A method and apparatus for carrying out highly efficient exothermal reaction between nickel and hydrogen atoms in a tube, preferably, though not necessary, a metal tube filled by a nickel powder and heated to a high temperature, preferably, though not necessary, from 150 to 5000 C are herein disclosed. In the inventive apparatus, hydrogen is injected into the metal tube containing a highly pressurized nickel powder having a pressure, preferably though not necessarily, from 2 to 20 bars.

(21) Appl. No.: **12/736,193**

(22) PCT Filed: **Aug. 4, 2009**

(86) PCT No.: **PCT/IT2008/000532**

§ 371 (c)(1),
(2), (4) Date: **Sep. 16, 2010**

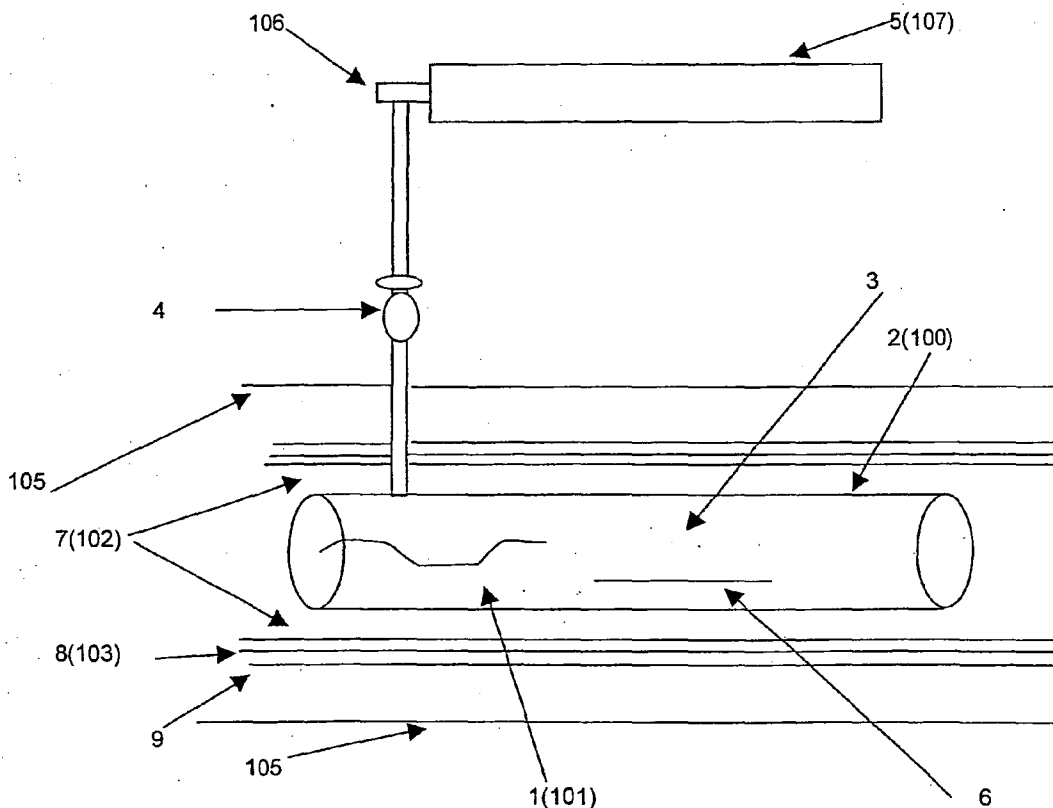

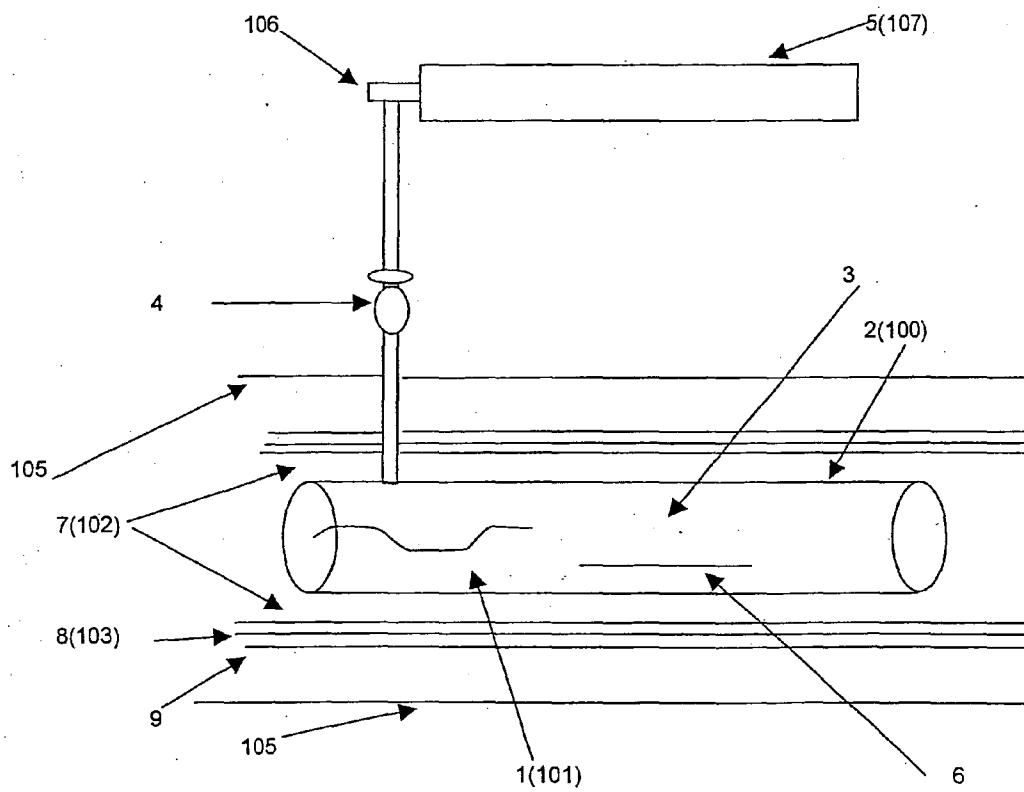

FIG. 1

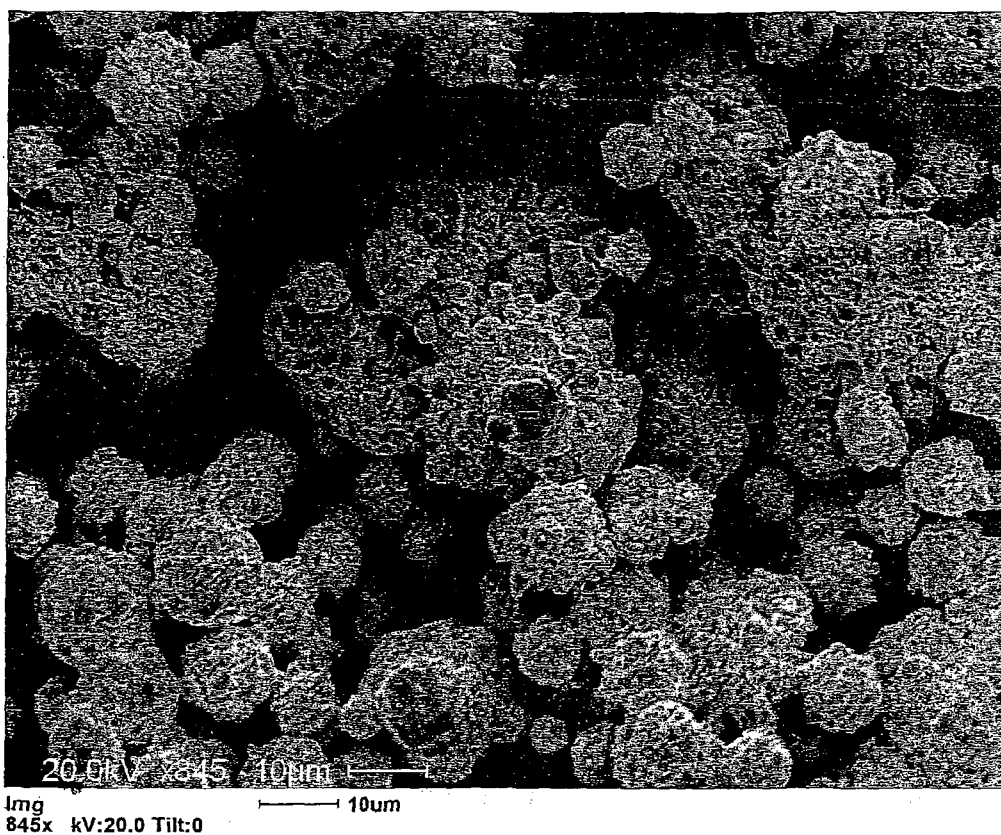

FIG. 2

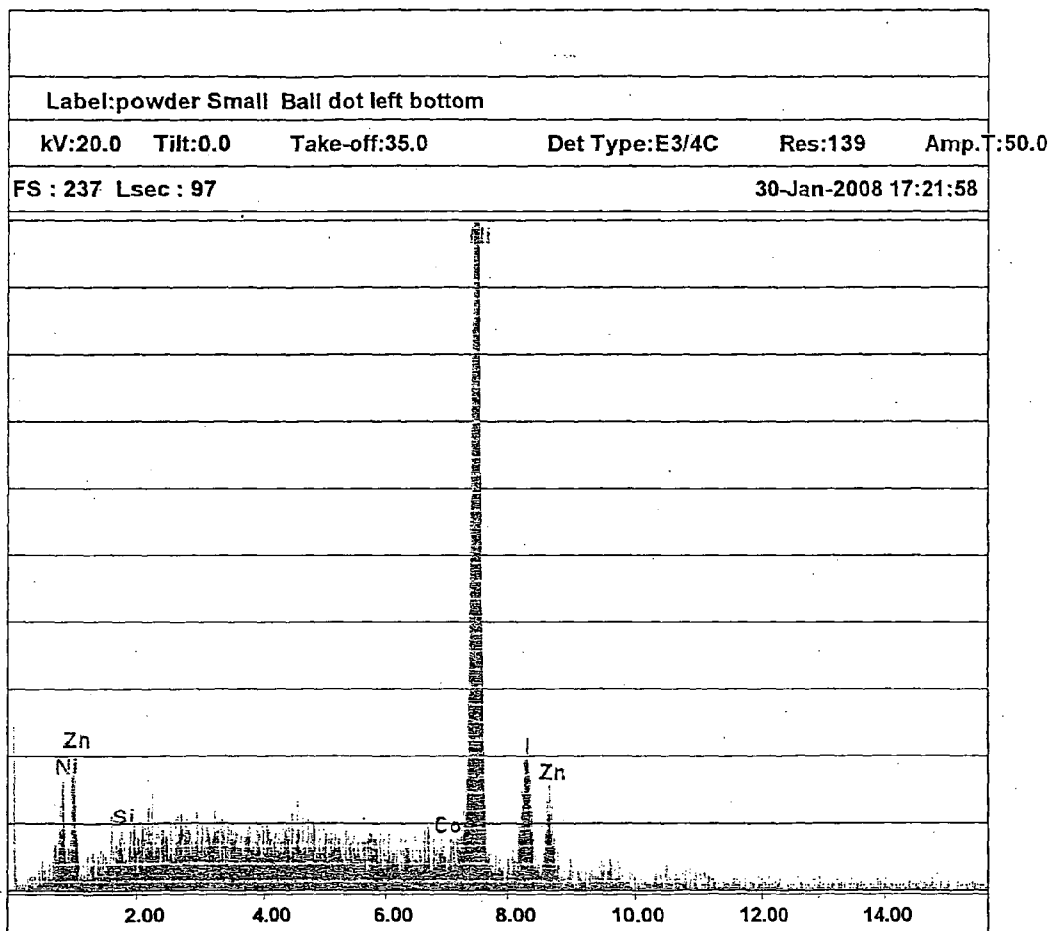

FIG. 3

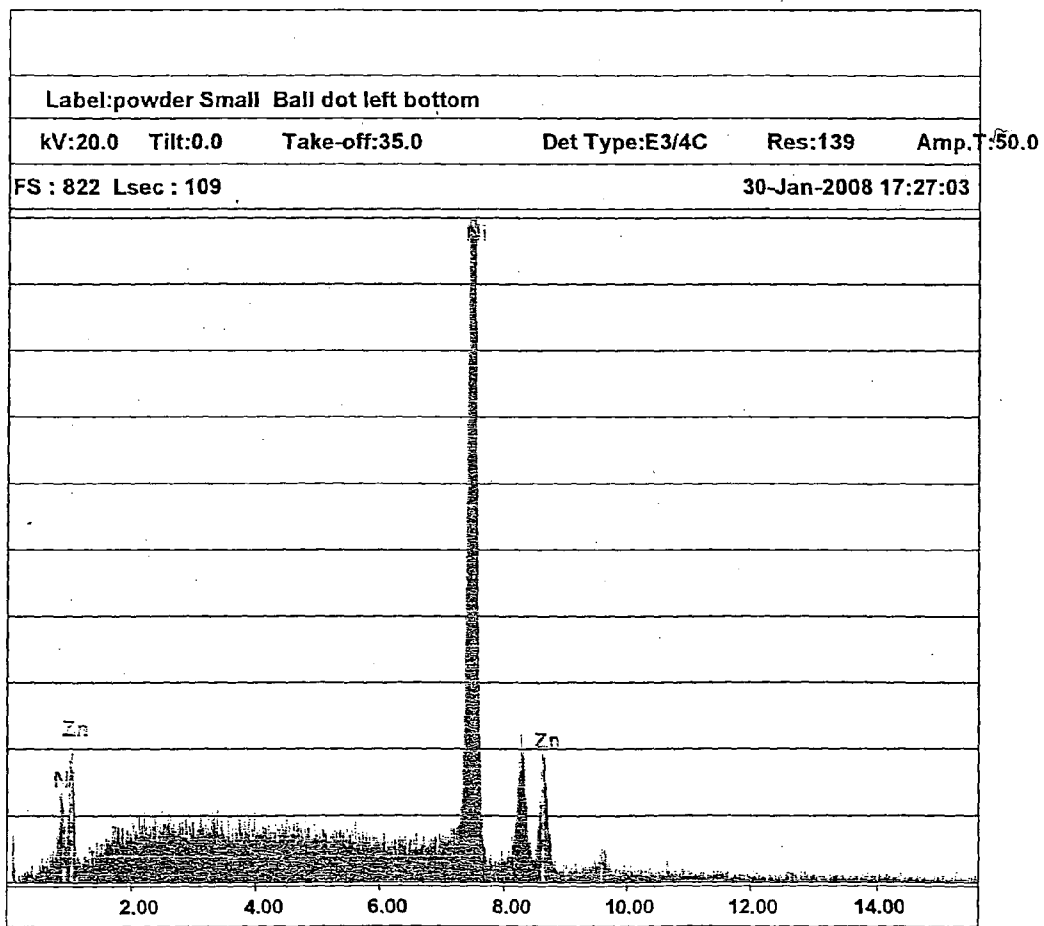

FIG. 4

**METHOD AND APPARATUS FOR CARRYING
OUT NICKEL AND HYDROGEN
EXOTHERMAL REACTION**

BACKGROUND OF THE INVENTION

[0001] The present invention relates to a method and apparatus for carrying out nickel and hydrogen exothermal reactions, and has been stimulated by the well known requirement of finding energy sources alternative to fossil sources, to prevent atmospheric carbon dioxide contents from being unnecessarily increased.

[0002] For meeting the above need non polluting energy sources should be found which do not involve health risks, are economically competitive with respect to oil sources susceptible to be easily discovered and exploited and naturally abundant.

[0003] Many of the above alternative energy sources have already been explored and operatively tested even on an industrial scale, and comprise biomasses, solar energy used both for heating and photovoltaic electric generation purposes, aeolian energy, fuel materials of vegetable or agricultural nature, geothermal and sea wave energy and so on.

[0004] A possible alternative to natural oil, is the uranium-fission nuclear energy. However, yet unresolved problems affect nuclear energy such as great safety and waste material processing problems, since, as is well known, radioactive waste materials remain dangerously active for thousands or millions of years, with consequent great risks for persons living near radioactive waste disposal-off places.

[0005] To the above the fact should also be added that, at present, a nuclear fusion based on a laser actuated inertial confining method does not allow to make efficient power systems.

[0006] The above drawbacks are also true for deuterium-tritium fusion processes, as shown by the operating times estimated for the ITER project, which should within the year 2025 should allow to construct power systems according to the so-called DEMO project to make, within the year 2035, the first fusion power station.

[0007] In fact, up to now, the so-called "cold" fusion, after an early announcement by Fleischmann and Pons in 1989 (M. Fleischmann, M. Hawkins, S. Pons: *Journal Electroanal. Chem.*, 261,301-1989), notwithstanding several exploiting attempts on a world-wise scale, has not provided useful and reliable systems capable of generating energy for normal, industrial or domestic applications.

[0008] The most intelligent work performed in the fusion field, which work has been accurately studied by the present inventor for practicing his invention, is a study of Prof. Sergio Focardi, (Dipartimento di Fisica dell'Università di Bologna), and Prof. Francesco Piantelli, (Dipartimento di Fisica dell'Università di Siena) as disclosed in the following bibliographic documents:

[0009] S. Focardi, F. Piantelli: Produzione di energia e reazioni nucleari in sistemi Ni—H a 400° C., *Atti della Conferenza Nazionale sulla politica energetica in Italia*, Università di Bologna, 18-19 aprile 2005.

[0010] S. Focardi, R. Habel, F. Piantelli: Anomalous heat production in Ni-H systems, *Nuovo Cimento Vol. 107*, pp 163-167, 1994

[0011] S. Focardi, V. Gabbiani, V. Montalbano, F. Piantelli, S. Veronesi: Large excess in heat production in Ni-H systems, *Nuovo Cimento Vol. 111 A* pp. 1233-1241, 1998

[0012] A. Battaglia, L. Daddi, S. Focardi, V. Gabbiani, V. Montalbano, F. Piantelli, P. G. Sona, S. Veronesi: Neutron emission in Ni—H systems, *Nuovo Cimento Vol. 112 A* pp 921-931, 1999

[0013] S. Focardi, V. Gabbiani, V. Montalbano, F. Piantelli, S. Veronesi: On the Ni-H systems, *Asti Workshop in Hydrogeldeuterium loaded metals*, pp 35-47, 1997

[0014] E. G. Campari, S. Focardi, V. Gabbiani, V. Montalbano, F. Piantelli, E. Porcu, E. Tosti, S. Veronesi: Ni—H systems, *Proceedings of the 8th Conference on Cold Fusion*, pp 69-74, 2000.

[0015] The present inventor, moreover, has also accurately studies the following related patents: U.S. Pat. No. 6,236,225, U.S. Pat. No. 5,122,054, US-H466, U.S. Pat. No. 4,014,168, U.S. Pat. No. 5,552,155, U.S. Pat. No. 5,195,157, U.S. Pat. No. 4,782,303, U.S. Pat. No. 4,341,730, US-A-20010024789.

[0016] An analysis of the above mentioned references shows that:

[0017] 1—all experiments performed based on cold fusion have not permitted to generate power in such an amount to be reliably and constantly exploited in industrial applications;

[0018] 2—all the uranium based methods and systems have not up to now solved the problem of safely disposing of nuclear waste materials;

[0019] 3—all the nuclear fusion based methods and systems have not been shown as capable of generating significant amounts of energy while allowing the fusion process to be safely monitored;

[0020] 4—all the magnetic and inertial confining based methods and systems, such as the plasma fusion method, cannot be properly economically managed; and

[0021] 5—the catalyzed fusion of negative muons based methods and systems cannot be used because of the muon short life.

SUMMARY OF THE INVENTION

[0022] Accordingly, the aim of the present invention is to provide a method allowing to produce energy in an economic, convenient, reliable and repetitive manner, without generating radiations and radioactive waste materials.

[0023] Within the scope of the above mentioned aim, a main object of the invention is to provide such a method which can be carried out in small size systems, adapted to be easily controlled and allowing to heat individual places at an operating cost less than that of commercially available heating systems.

[0024] According to one aspect of the present invention, the above mentioned aim and objects, as well as yet other objects, which will become more apparent hereinafter, are achieved by a method and apparatus for carrying out a highly efficient exothermal reaction between nickel atoms and hydrogen atoms, in a tube, preferably, though not exclusively made of a metal, filled by a nickel powder and heated to a high temperature preferably, though not necessarily, from 150 to 500° C., by injecting hydrogen into said metal tube said nickel powder being pressurized, preferably, though not necessarily, to a pressure from 2 to 20 bars.

[0025] In applicant exothermal reaction the hydrogen nuclei, due to a high absorbing capability of nickel therefor, are compressed about the metal atom nuclei, while said high temperature generates internuclear percussions which are made stronger by the catalytic action of optional elements, thereby triggering a capture of a proton by the nickel powder,

with a consequent transformation of nickel to copper and a beta+ decay of the latter to a nickel nucleus having a mass which is by an unit larger than that of the starting nickel.

[0026] The present inventor believes that in this reaction is possibly involved a capture of a proton by a nickel nucleus which is transformed into a copper nucleus with a consequent beta decay of the formed unstable copper (Cu 59-64) since the produced thermal energy is larger, as it will be thereafter demonstrated, than the energy introduced by the electric resistance.

[0027] It is believed that the nickel nuclei are transformed to copper since the mass (energy) of the final status (copper isotope) is less than the overall mass (energy) of the starting status (nickel isotope+proton).

[0028] The exothermal reaction thereon Applicant's invention is based differs from those adopted by prior searchers since the inventor has not tried to demonstrate an emission of elementary particles supporting a validity of a theory, but he has exclusively tried to provide an amount of energy larger than the consumed energy amount, to just achieve a practical method and apparatus for generating an energy amount larger than the consumed energy, and this by exploiting nuclear energy generating processes starting from electrochemical energy.

[0029] Thus, the inventive apparatus has been specifically designed for producing the above mentioned energy in a reliable, easily controllable, safe, repeatable manner, for any desired applications.

[0030] In particular, the inventive apparatus is coated by boron layers and lead plates both for restraining noxious radiations and transforming them into energy, without generating residue radiations and radioactive materials.

[0031] In this connection it is pointed out that all prior attempts to generate like types of energy, have brought to small energy amounts generating prototypes not suitable for a safe industrial use, because of the theoretical nature of the performed searches.

SUMMARY OF THE INVENTION

[0032] Thus, the aim of the present invention is to provide an energy generating apparatus adapted to operate in a reliable and repeatable manner and including a plurality of series and parallel connectable apparatus modules, thereby generating an impressively high energy amount by so bombarding a nickel atom by a hydrogen atom, to provide a large atomic mass loss copper atom to be transformed into energy, based on the Einstein's equation, plus a beta decay energy of the radioactive copper atoms.

[0033] The following discussion may be considered as valid for some (radioactive) Cu isotopes, but not for the two stable copper isotopes (^{63}Cu and ^{65}Cu) which do not decay.

[0034] As the copper atom decays, an energy emitting positive beta decay occurs, according to the following equations:

$$P = N + e^+ + \nu,$$

where

P=proton

N=neutron

e^+ =positron

ν =neutrino

[0035] The positron forms the electron antiparticle, and hence, as positrons impact against the nickel electrons, the electron-positron pairs are annihilated, thereby generating a huge amount of energy.

[0036] In fact, few grams of Ni and H would produce an energy amount equivalent to that of thousands oil tons, as it will become more apparent hereinafter, without pollutions, greenhouse effects, or carbon dioxide increases, nuclear and other waste materials, since the radioactive copper isotopes produced in the process will decay to stable nickel isotopes by beta+processes, in a very short time.

[0037] For clearly understanding the following detailed discussion of the apparatus, it is necessary to at first consider that for allowing nickel to be transformed into stable copper, it is necessary to respect the quantic laws. Accordingly, it is indispensable to use, for the above mentioned exothermal reactions, a nickel isotope having a mass number of 62, to allow it to transform into a stable copper isotope 62. All the other Ni isotopes, on the other hand, will generate unstable Cu, and, accordingly, a beta decay.

[0038] Considering that about 10^6 tons nickel for year are produced through the world and since, as it will be disclosed hereinafter in Table 1, 1 g nickel would generate an energy amount equivalent to that produced by 517 tons oil, thus the yearly produced nickel amount, assuming that only $1/10,000$ generates nuclear processes, will provide 1,000,000,000, $000 \times 517 / 10000 = 51,700,000,000$ (oil equivalent) ton per year.

[0039] And this without considering the fact that the yearly nickel production could be easily increased, depending on demand, and that, like mineral oil, nickel can be recovered and remelted from nickel scraps of steelwork and electronic applications.

[0040] Actually, nickel is one of the most abundant metals of the Earth crust.

BRIEF DESCRIPTION OF THE DRAWINGS

[0041] Further characteristics and advantages of the present invention will become more apparent hereinafter from the following detailed disclosure of a preferred, though not exclusive, embodiment of the invention, which is illustrated, by way of an indicative, but not limitative, example, in the accompanying drawings, where:

[0042] FIG. 1 is a constructional diagram of the apparatus according to the present invention;

[0043] FIG. 2 is a picture, taken by a $1.400\times$ electronic microscope, showing the nickel powder (on a $1.400\times$ scale), withdrawn by the apparatus;

[0044] FIGS. 3 and 4 are electronic microscope diagrams related to the powder atomic composition, at the two points shown by the arrows in FIG. 2.

DESCRIPTION OF THE PREFERRED EMBODIMENT

[0045] With reference to the number references of the above mentioned figures, the apparatus according to the present invention comprises an electric resistance 1, enclosed in a metal tube 2, further including therein a nickel powder 3.

[0046] A solenoid valve 4 adjusts the pressure under which hydrogen 5 is introduced into the metal tube.

[0047] Both the temperature generated by the electric resistance or resistor and the hydrogen injection pressure can be easily adjusted either to constant or pulsating values.

[0048] More specifically, the electric resistance, or other heat source, is switched off as the exothermal reaction gen-

erating energizing status is triggered. A thermostat will hold said heat source operating, depending on the temperature in the circuit.

[0049] The assembly comprising said electric resistance and nickel holding copper tube is shielded from the outer environment by using, respectively from the inside to the outside:

[0050] a) a jacket **7** including water and boron, or only boron

[0051] b) a further lead jacket **8**, which, optionally, though not necessarily, may be coated by a steel layer **9**.

[0052] The above mentioned coatings are so designed as to restrain all radiations emitted by the exothermal reaction and transform said radiation into thermal energy.

[0053] The heat generated by the particle decay and nuclear transformations will heat the primary fluid, comprising borated water, thereby said primary fluid, in turn, will exchange heat with the secondary circuit, in turn heated by said primary fluid and conveying the produced thermal energy to desired applications, such as electric power, heating, mechanical energy, and so on.

[0054] In the absence of a primary fluid, the fluid to be heated will exchange heat directly with the lead and steel jacket.

[0055] According to a further embodiment of the invention, the apparatus further comprises the following features.

[0056] Nickel is coated in a copper tube **100**, including a heating electric resistance **101**, adjusted and controlled by a controlling thermostat (not shown) adapted to switch off said resistance **101** as nickel is activated by hydrogen contained in a bottle **107**.

[0057] A first steel-boron armored construction **102**, coated by a second lead armored construction **103**, protect both the copper tube, the hydrogen bottle connection assembly **106**, and the hydrogen bottle or cylinder **107**, thereby restraining radiations through the overall radiation life, allowing said radiations to be transformed into thermal energy.

[0058] On the outside of the lead armored construction, the copper reactor cooling water, circulates through a steel outer pipe assembly **105**, and this conveyed to thermal energy using devices.

[0059] The above disclosed prototype can also be used as a heating module which, in a series and/or parallel coupling relationship with other like modules, will provide a basic core desired size and power heating systems.

[0060] A practical embodiment of the inventive apparatus, installed on Oct. 16, 2007, is at present perfectly operating 24 hours per day, and provides an amount of heat sufficient to heat the factory of the Company EON of via Carlo Ragazzi 18, at Bondeno (Province of Ferrara).

[0061] For better understanding the invention, the main components of the above mentioned apparatus have been schematically shown in Table 2.

[0062] The above mentioned apparatus, which has not been yet publicly disclosed, has demonstrated that, for a proper operation, the hydrogen injection must be carried out under a variable pressure.

[0063] The electric resistance temperature controlling thermostat has been designed to switch off said electric resistance after 3-4 hours of operation, thereby providing self-supplied system, continuously emitting thermal energy in an amount larger than that initially generated by said electric resistance, which mode of operation is actually achieved by an exothermal reaction.

[0064] As it will be shown in a detailed manner in the following Table 1, it is possible to calculate that, supposing a full transformation, a mole, that is 58 g nickel, generate the same amount of energy obtained by burning about 30,000 tons of oil.

[0065] FIGS. 2-5 show data measured on Jan. 30, 2008 which basically demonstrate that the invention actually provides a true nuclear cold fusion.

[0066] The photo of FIG. 2, (obtained by a 1.400× electronic microscope) shows the nickel powder on a 1.400× scale, as withdrawn from the apparatus: in particular said photo clearly shows the flake granules, greatly promoting an absorption of the hydrogen atoms by the nickel nuclei.

[0067] The two arrows in the figure show the two positions of the powder sample thereon the electronic microscope tests for detecting the powder atomic composition have been carried out.

[0068] The two graphs of FIGS. 3 and 4 have been made by the electronic microscope of Dipartimento di Fisica dell'Università di Bologna, under the supervision of Prof. Sergio Focardi, on Jan. 30, 2008, and are related to the powder atomic composition at the two above points of FIG. 2.

[0069] In particular, said graphs clearly show that zinc is formed, whereas zinc was not present in the nickel powder originally loaded into the apparatus said zinc being actually generated by a fusion of a nickel atom and two hydrogen atoms.

[0070] This demonstrates that, in addition to fusion, the inventive reaction also provides a nickel nucleus fission phenomenon generating lighter stable atoms.

[0071] Moreover, it has been found that, after having generated energy the used powders contained both copper and lighter than nickel atoms (such as sulphur, chlorine, potassium, calcium).

[0072] This demonstrate that, in addition to fusion, also a nickel nucleus fission phenomenon generating lighter stable atoms occurs.

[0073] It has been found that the invention fully achieves the intended aim and objects.

TABLE 1

[0074] Determining the energy produced by a nickel mol.

[0075] 1 nickel mol=58 g

[0076] Avogadro number $6.022 \times 10^{23} \text{ mol}^{-1}$ =number of nickel atoms in 58 g nickel.

[0077] The energy generated in each hydrogen capture process has been evaluated (for each nickel isotope) from the difference between the initial mass (nickel+hydrogen) and the reaction end product mass.

[0078] A reasonable estimate, considering the different values for the different isotopes, is 10 MeV electron (a MeV corresponds to a million electron-volts and is the energy measuring unit, as conventionally used in nuclear physics).

[0079] Since 1 Mev is equivalent to a variation of mass of $1.78 \times 10^{-30} \text{ kg}$, the mass variation corresponding to an energy emission of 10 Mev is $1.78 \times 10^{-29} \text{ kg}$.

[0080] The mass loss corresponding to a transformation of an entire Ni mol can be calculated by multiplying the Avogadro number (6.022×10^{23}) time the mass variation of the single reaction.

[0081] Thus is obtained (for 58 g Ni)

[0082] $M=(6.022 \times 10^{23}) \times 1.7.8 \times 10^{-29} \text{ kg}=1.07 \times 10^{-5} \text{ kg}$

[0083] From the Einstein equation we have

[0084] $E=mc^2$ where c is the light speed $c=3 \times 10^8 \text{ m/s}$.

[0085] Thus, by replacing:

[0086] $J=1.07 \times 10^{-5} \times (3 \times 10^8)^2 = 9.63 \times 10^{11}$ J which can be approximated to 0.3×10^9 kcal (which can be approximated by defect to reserve).

[0087] This is an energy equivalent to about 30,000 ton oil considering a pci of 10,000 kcal/kg for mineral oil; thus, 58 g nickel will generate the same energy as that provided by 30,000 ton oil, that is 517 tons/gram.

TABLE 2

[0088] List of materials used for making prototypes for experimentally testing the inventive apparatus

[0089] Electric resistance: Frei, Brescia

[0090] Thermostat: Pic 16—cod. 1705—Frei

[0091] Lead shields: Picchi Srl—Brugherio (Milan)

[0092] Hydrogen: Linde Gas Italia, Arluno (Milan)

[0093] Pressure reducer: Linde Gas Italia

[0094] Powder nickel: Gerli Metalli—Milan

[0095] Boron: Danilo Dell'Amore Srl—Bologna

[0096] Copper tube: Italchimici—Antezate (Brescia)

[0097] Laser beam temperature measuring device: Raytheon, USA

[0098] Pressure gauge: Elaborazione—Dipartimento di Fisica—Università degli Studi di Bologna

[0099] Neutron measuring device: Elaborazione—Dipartimento di Fisica—Università degli Studi di Bologna

[0100] Chemical-physical analyses:—Dipartimento di Fisica—Università degli Studi Bologna.

1. A method for carrying out an hexothermal reaction of nickel and hydrogen, characterized in that said method comprises the steps of providing a metal tube, introducing into said metal tube a nanometric particle nickel powder and injecting into said metal tube a hydrogen gas having a temperature much greater than 150° C. and a pressure much greater than 2 bars.

2. A method according to claim 1, characterized in that said hydrogen temperature varies in a range from 150 to 500° C.

3. A method according to claim 1, characterized in that said nickel powder is a nickel isotope powder.

4. A method according to claim 1, characterized in that said hydrogen is injected into said tube under a pulsating pressure.

5. A method according to claims 1 and 2, characterized in that said hydrogen temperature is a variable temperature which varies in said range from 150 to 500° C.

6. A method according to claim 1, characterized in that said metal tube is a copper metal tube.

7. A modular apparatus for providing a hexothermal reaction by carrying out the method according to claim 1, characterized in that said apparatus comprises a metal tube (2) including a nanometric particle nickel powder (3) and a high temperature and pressure hydrogen gas.

8. A method according to claim 1, characterized in that in said method catalyze materials are used.

9. An apparatus method according to claim 7, characterized in that said nickel powder filled metal tube (2) is a copper tube, said copper tube further including at least a heating electrical resistance, said tube being encompassed by a jacket (7) including either water and boron or only boron, said jacket (7) being encompassed by a further lead jacket (8) in turn optionally encompassed by a steel layer (9), said jackets (7, 8) being adapted to prevent radiations emitted from said copper tube (2) from exiting said copper tube (2), thereby also transforming said radiations into thermal energy.

10. An apparatus according to claim 1, characterized in that said apparatus comprises, encompassing said nickel powder, hydrogen and electric resistance (101) containing copper tube (100) a first steel-boron armored construction (102) encompassed by a second lead armored construction (103) for protecting said copper tube (100), a hydrogen bottle connection assembly (106) and a hydrogen bottle (107), said apparatus further comprising, outside of said lead armored construction (103), a cooling water steel outer pipe assembly (105).

* * * * *