

# EXCESS HEAT IN ELECTROLYSIS EXPERIMENTS AT ENERGETICS TECHNOLOGIES

I. Dardik, T. Zilov, H. Branover, A. El-Boher, E. Greenspan,  
B. Khachatorov, V. Krakov, S. Lesin, and M. Tsirlin

Energetics Technologies Ltd.

Omer, Israel

[lesin@energetics.co.il](mailto:lesin@energetics.co.il)

Presented at the  
11<sup>th</sup> International Conference on Cold Fusion, ICCF-11  
Marseilles, France  
November 1 - 6, 2004

# CONTENTS

1. Presentation objective
2. SuperWaves<sup>©</sup> used for driving the cell
3. Review of glow discharge experiments
4. Description of ET electrolytic cells
5. Pd Cathode and its pretreatment
6. Excess heat obtained
7. Excess tritium
8. Material analysis

# PRESENTATION OBJECTIVES

- 1. Review of SuperWave<sup>®</sup> principles**
- 2. Review of Glow Discharge Experiments**
- 3. Description of 3 ET electrolytic cell experiments that resulted in significant excess heat generation:**

Experiment #	56	64a	64b
Cycle ?	4	1	2
Loading time (s)	80	5	16
Excess heat (EH) (%)	80	2500	1500
Duration of EH (h)	300	17	80
Excess energy (EE) (MJ)	3.1	1.1	4.6
Specific* EH (W/g Pd)	11	71	62
Specific* EE (KeV/Pd atom)	13.5	4.8	20 (24.8)

\* - pertaining to effective part of cathode ( 6 x 0.7 cm )

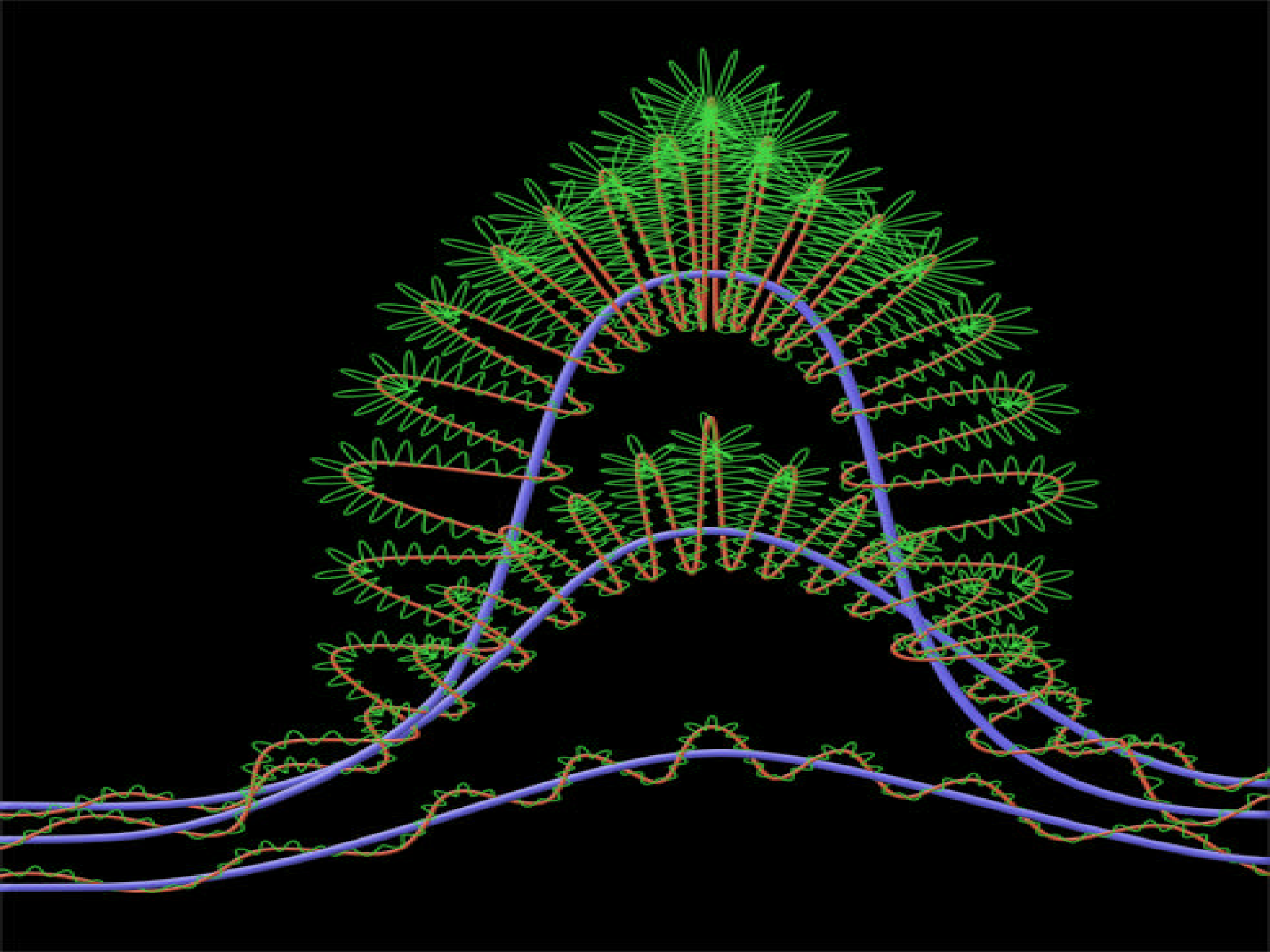

# EC are driving by SuperWaves



Operator

Parameters  
set up

Superwave form signal  
generation using  
LabView software

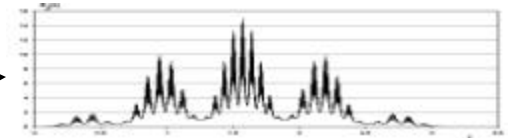

Low  
current

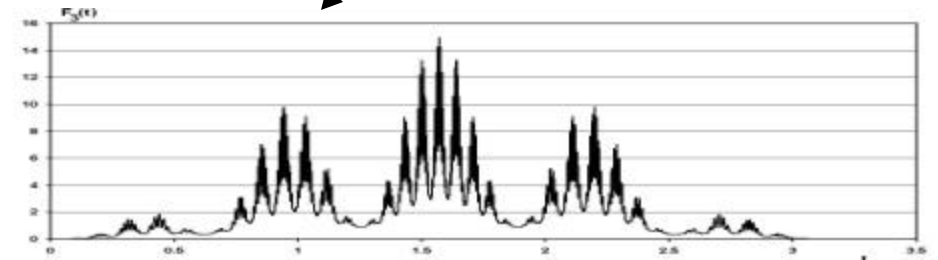

Experimental  
system

Current amplifier

# SuperWaves formation principles

$$F_0(t) = A_0 \sin^2(\omega_0 t)$$

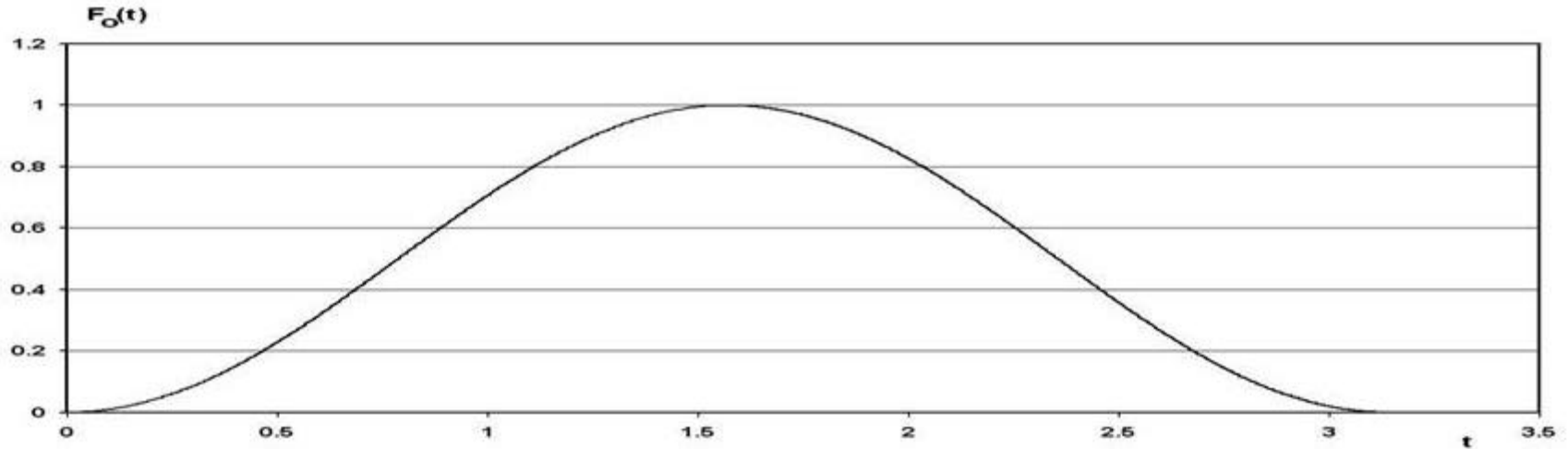

$$F_1(t) = A_0 \sin^2(\omega_0 t)(1 + A_1 \sin^2(\omega_1 t))$$

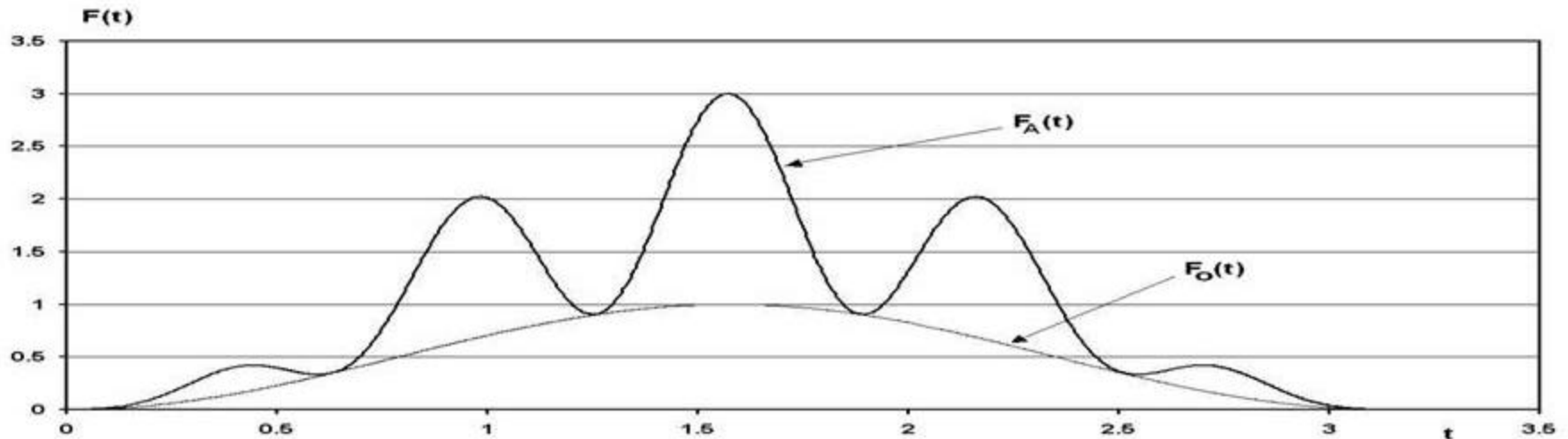

$$F_2(t) = A_0 \sin^2(\omega_0 t) [1 + A_1 \sin^2(\omega_1 t) (1 + A_2 \sin^2(\omega_2 t))]$$

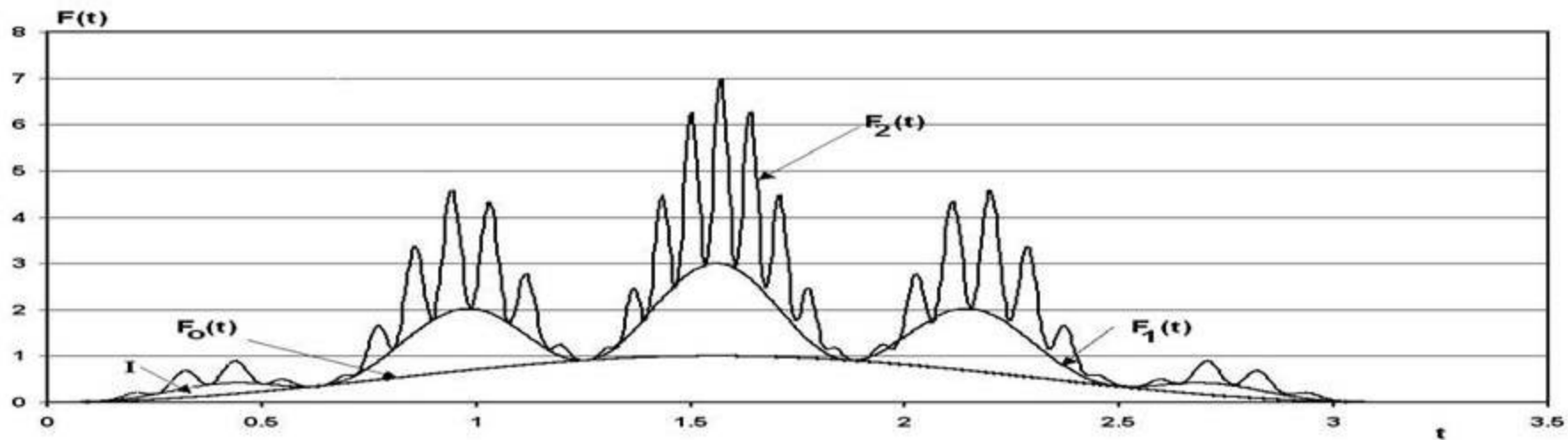

$$F_3(t) = A_0 \sin^2(\omega_0 t) [1 + A_1 \sin^2(\omega_1 t) (1 + A_2 \sin^2(\omega_2 t) (1 + A_3 \sin^2(\omega_3 t)))]$$

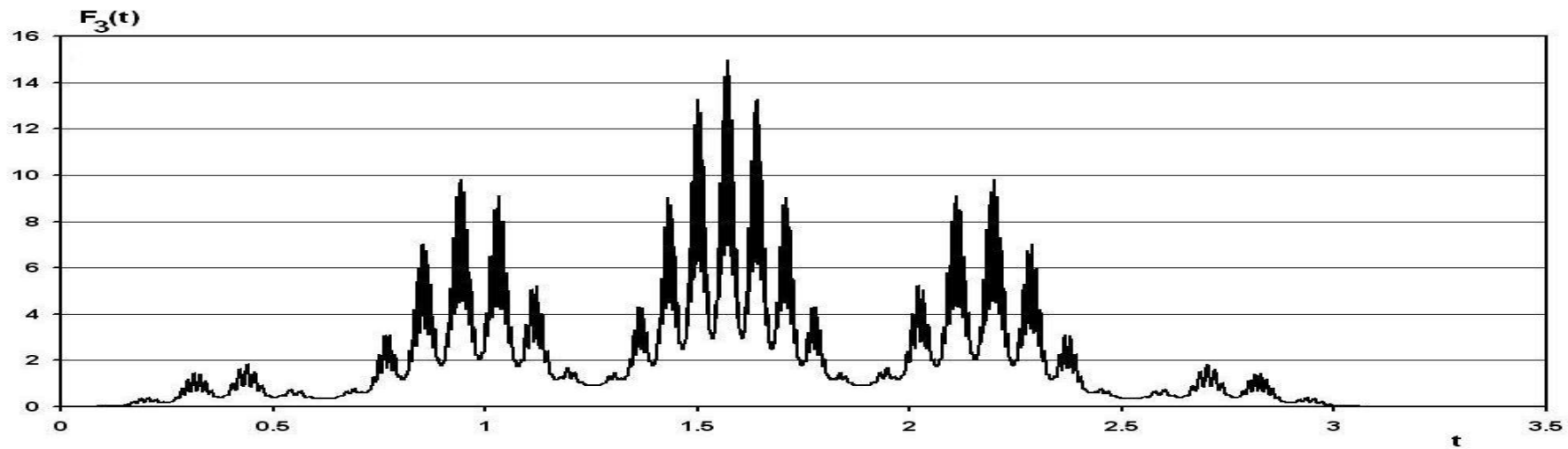

# Glow Discharge Cell

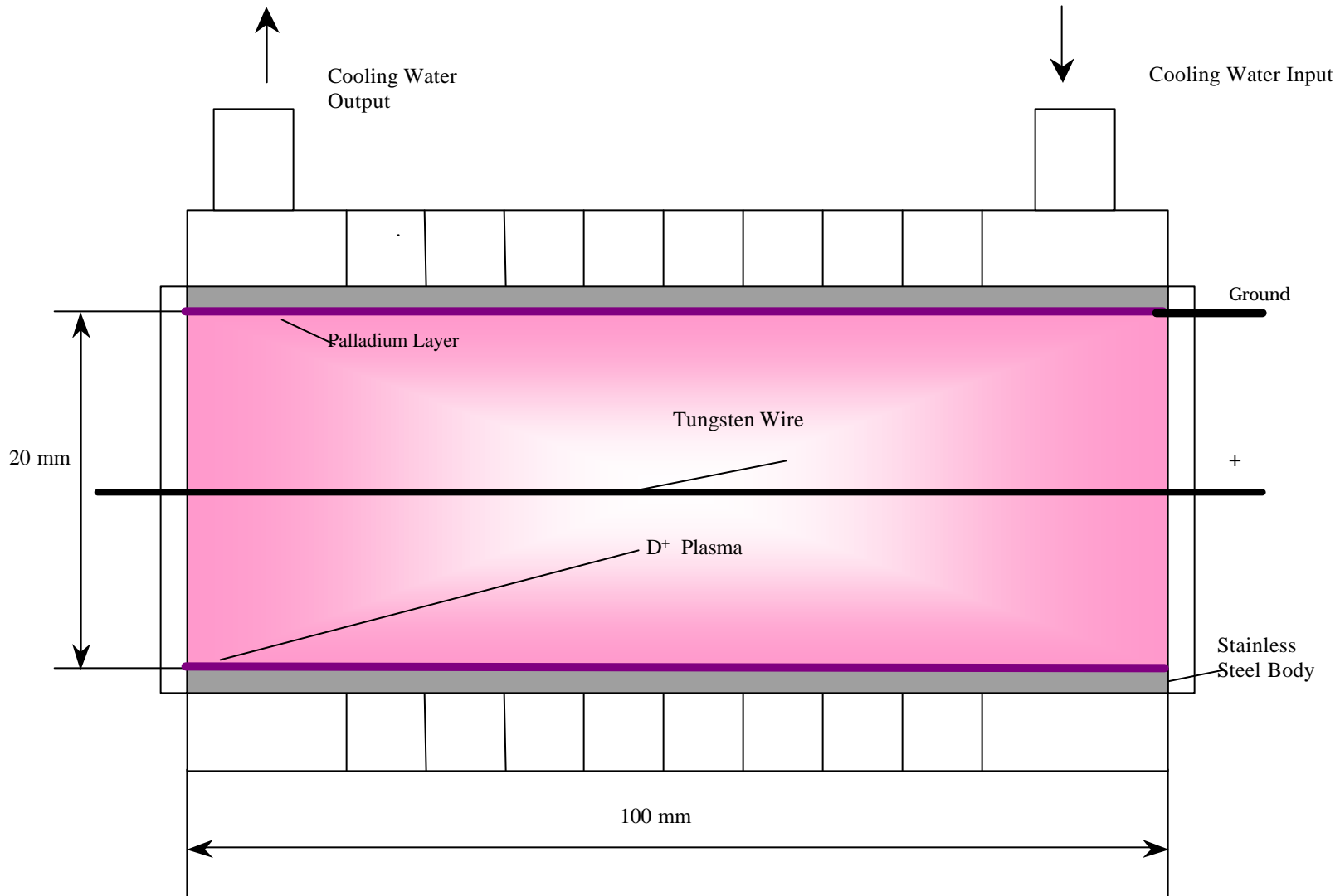

Conceptual Design



# Cell Assembly



# Experimental Results with thin Palladium film (about 1 $\mu\text{m}$ ) on Stainless Steel Body

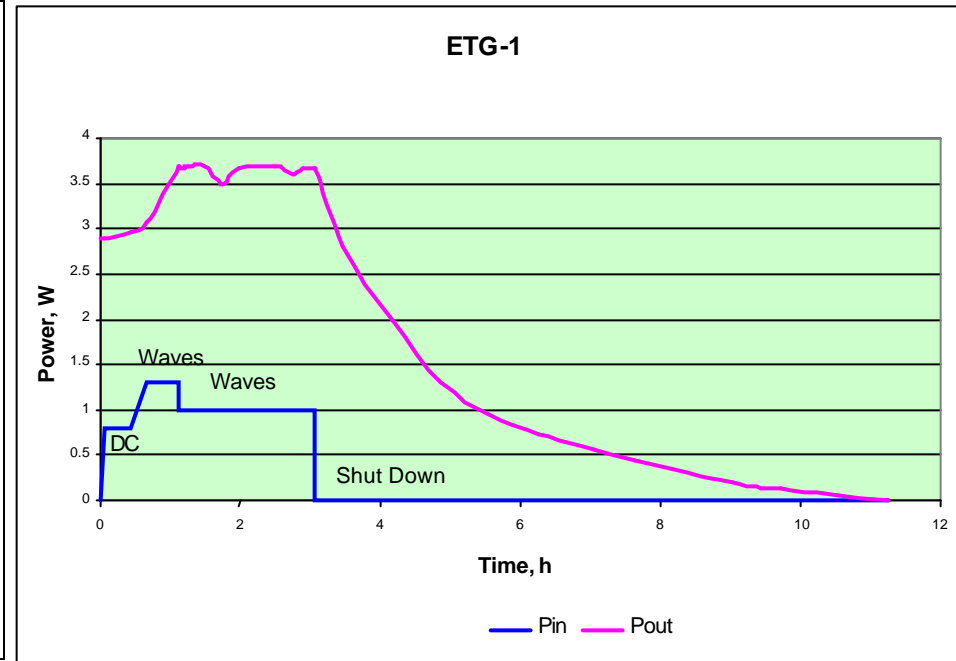
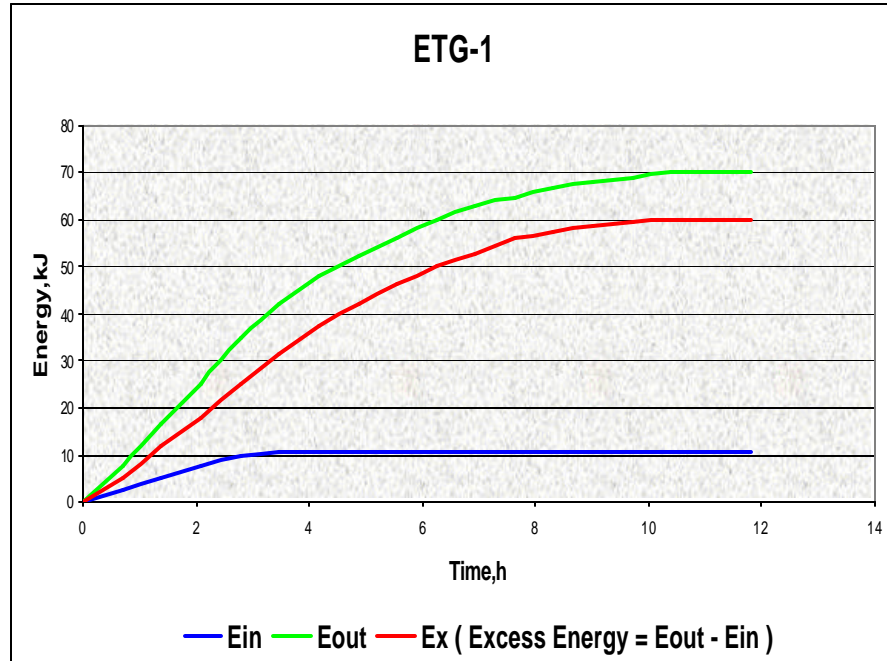

**Maximum Excess Power = 3.7 x Input Power**

**Total Excess Energy = 6.7 x Input Energy**

# Experimental Results with thick Palladium foil (100 $\mu\text{m}$ )

ETG-2

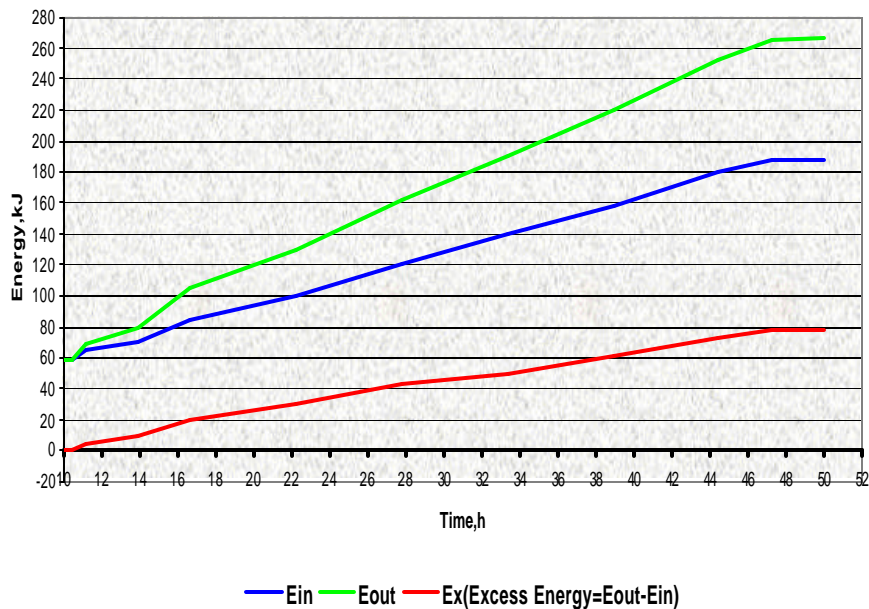

ETG-2

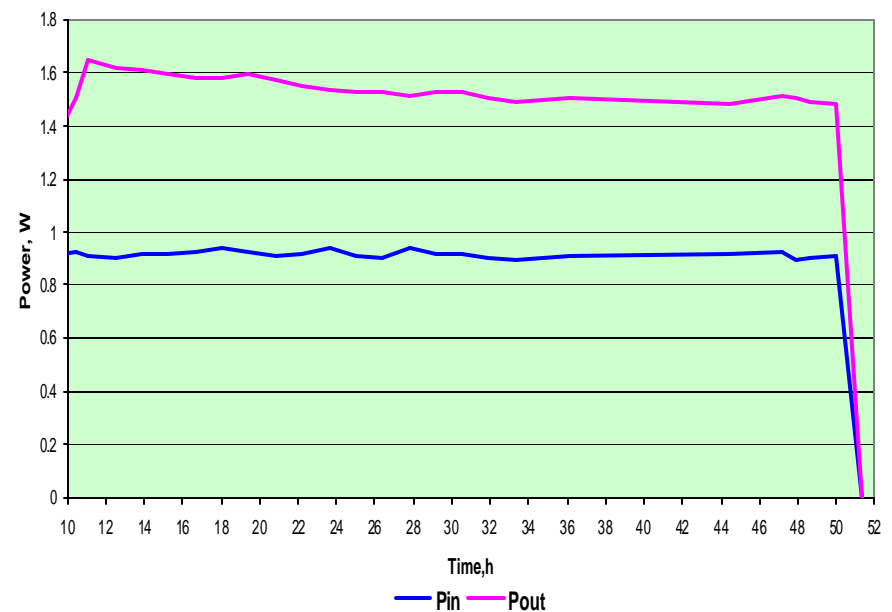

**Maximum Excess Power = 0.8 x Input Power**

**Total Excess Energy = 0.8 x Input Energy**

# Excess Heat Generation during 20 days

## Glow Discharge Experiment Cell ETG-2-18

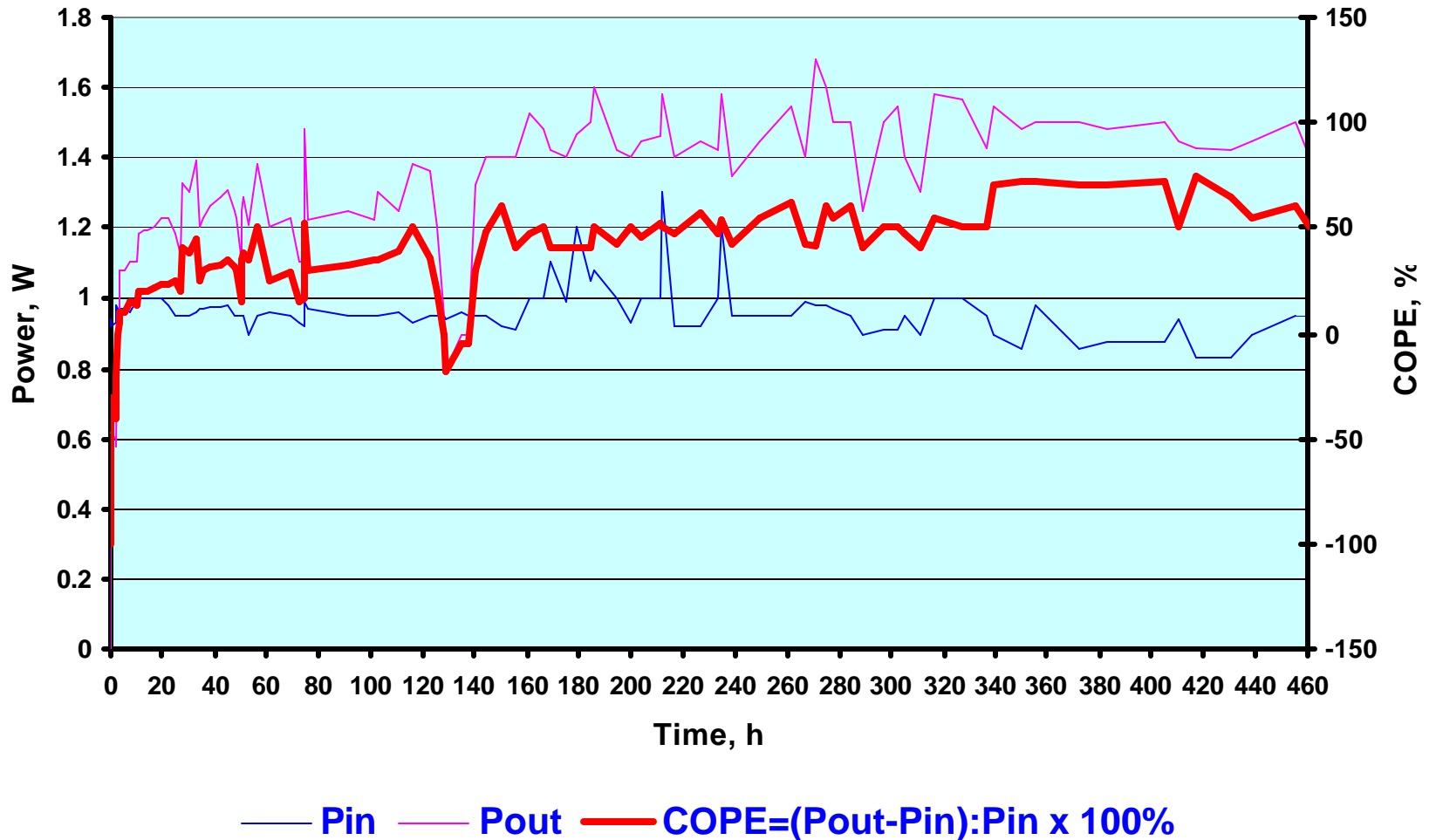

# Excess Energy during 20 days

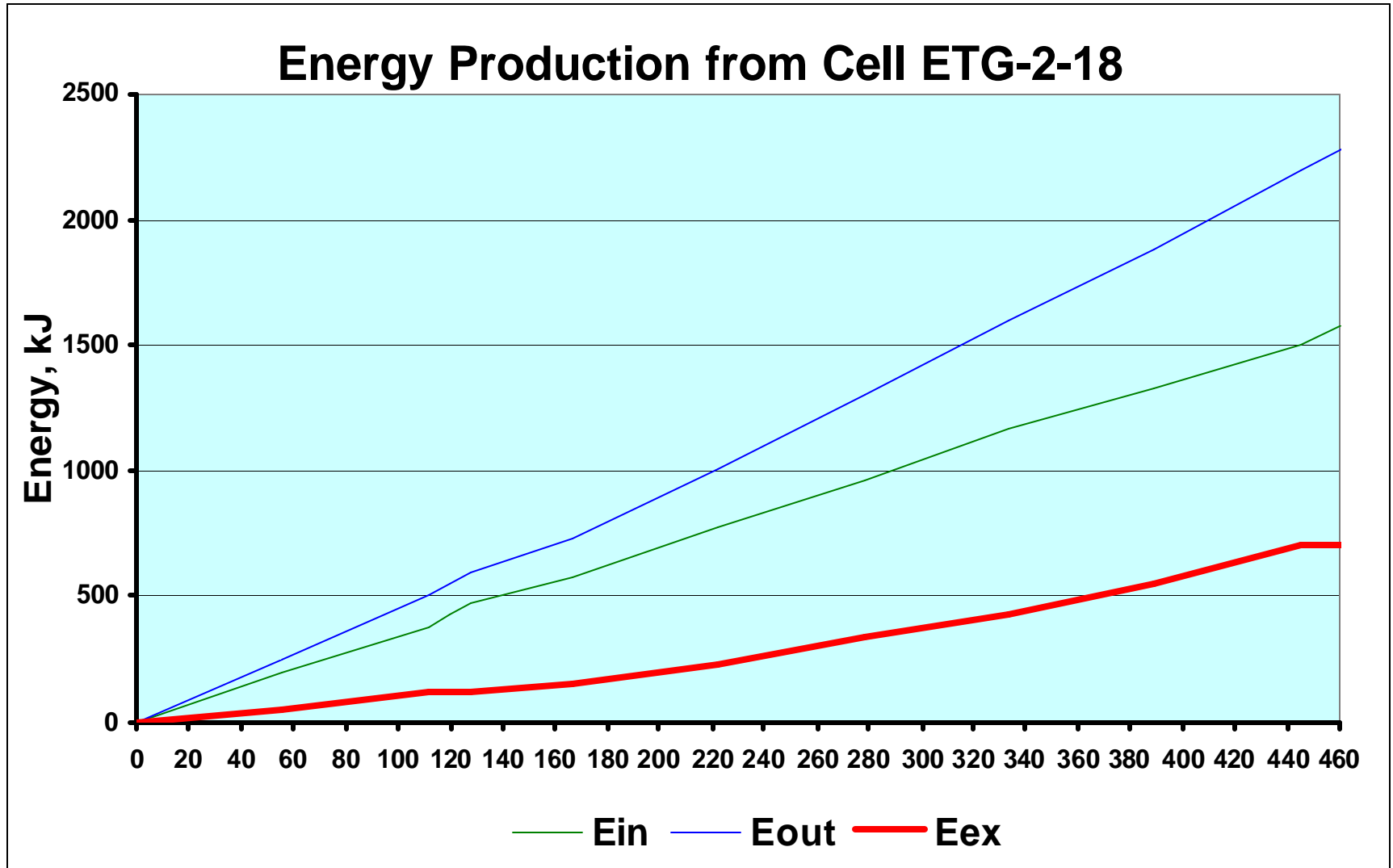

# “Heat After Death”

Energy Output after shutting down of GD Cell ETG-3-22

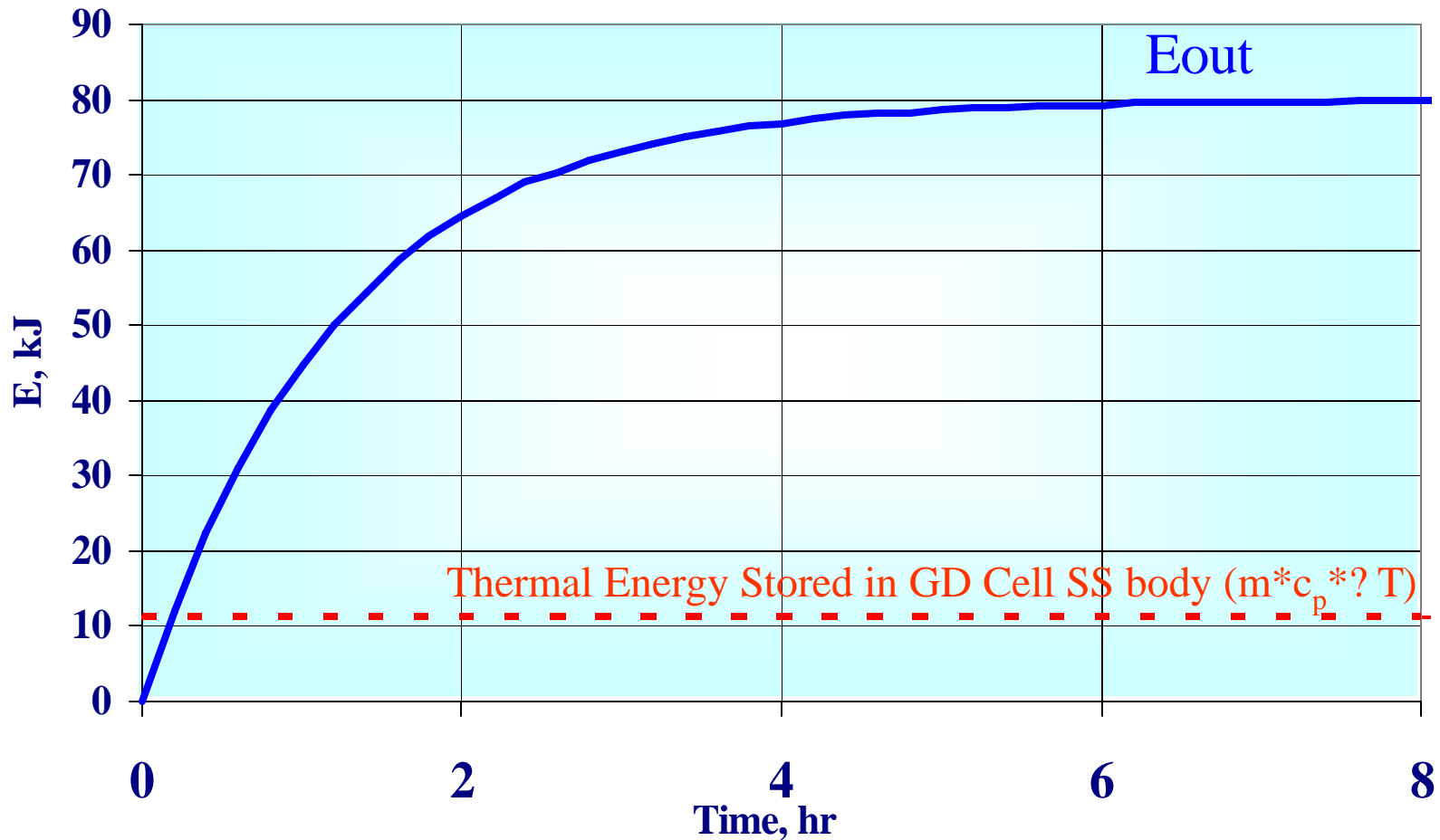

# ET Electrolytic Cell

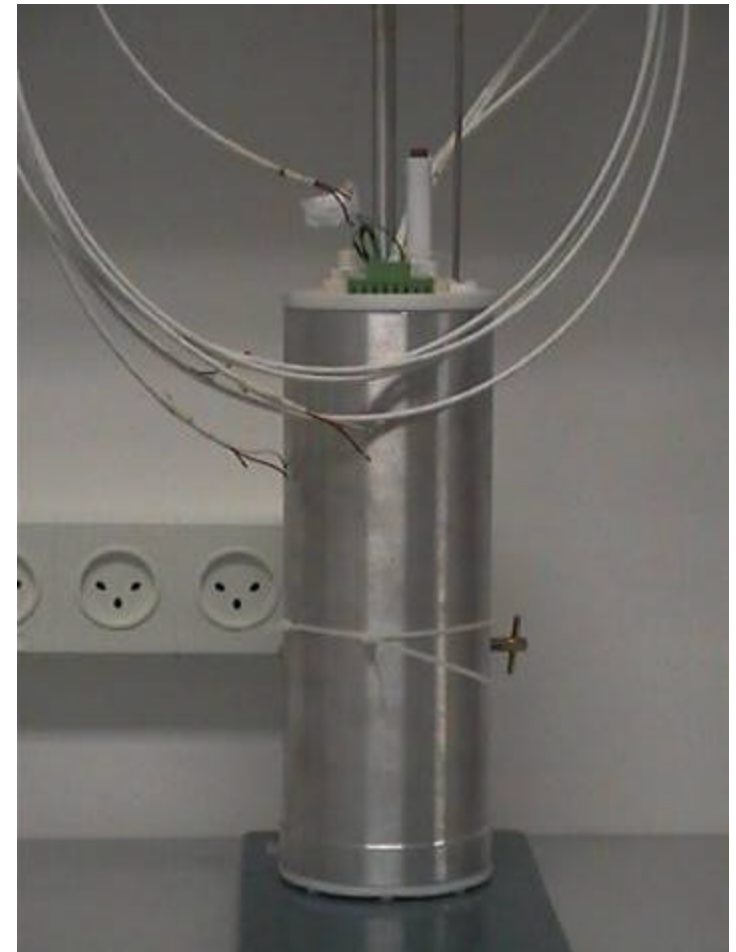
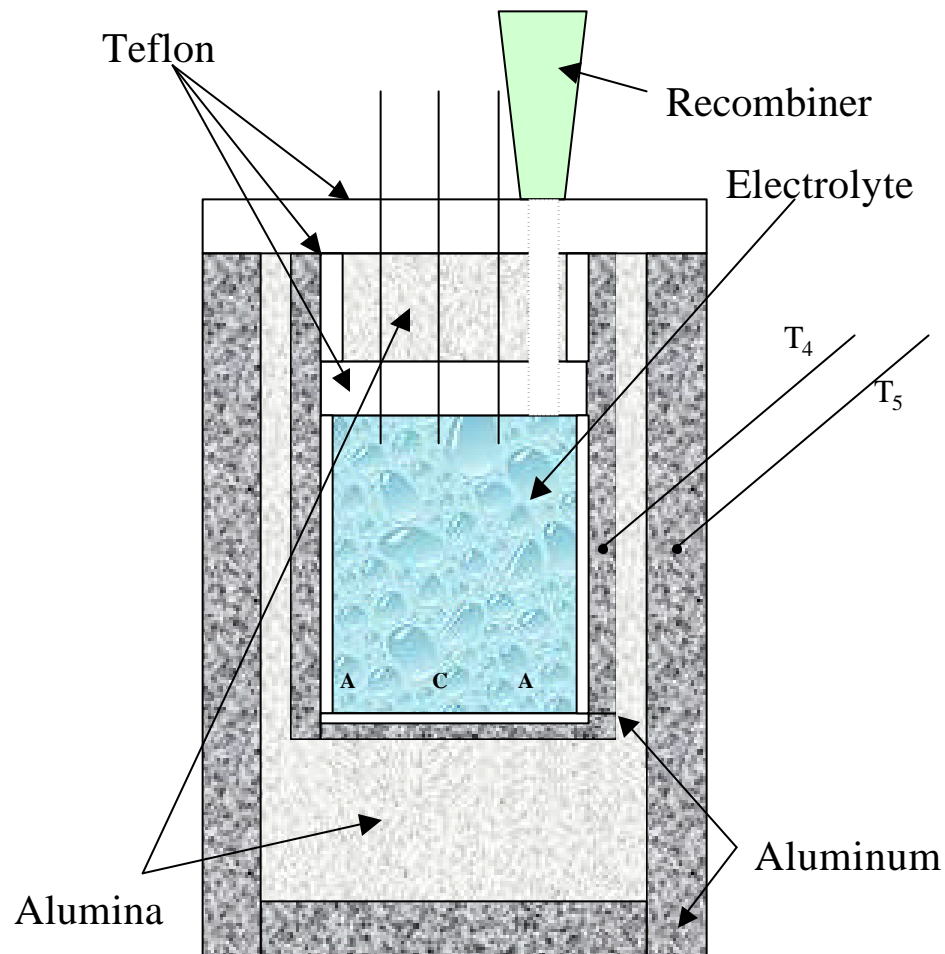

0.1M LiOD in low tritium content D<sub>2</sub>O (230 ml)

**EC is inside a Teflon beaker that is placed inside an isoperibolic calorimeter**

# Electrolytic Cell



Three cells are immersed in a constant temperature water bath of  $+2.5^{\circ}\text{C} \pm 0.25^{\circ}\text{C}$



# Cathode & Pre-treatment

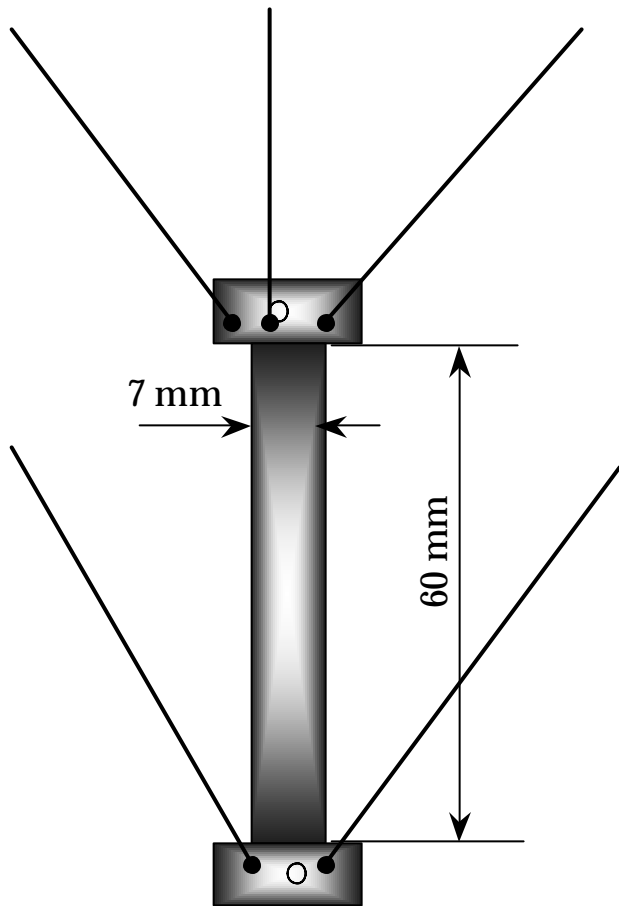

- 50  $\mu\text{m}$  Pd foil, prepared by  
**Dr. Vittorio Violante** (ENEA Frascati, Italy)
- Annealed at 870°C in vacuum for 1h
- Etched:
  - in Nitric Acid 65-67%; 1 min
  - in Aqua Regia 1:1 water solution; 1 min
- Rinsed:
  - D<sub>2</sub>O four times
  - Ethanol 95% twice
  - Ethanol Absolute once
- Dried:
  - in vacuum at ambient temperature for 24 h

# Typical Calibration Curve for Electrolytic Cell Calorimeter

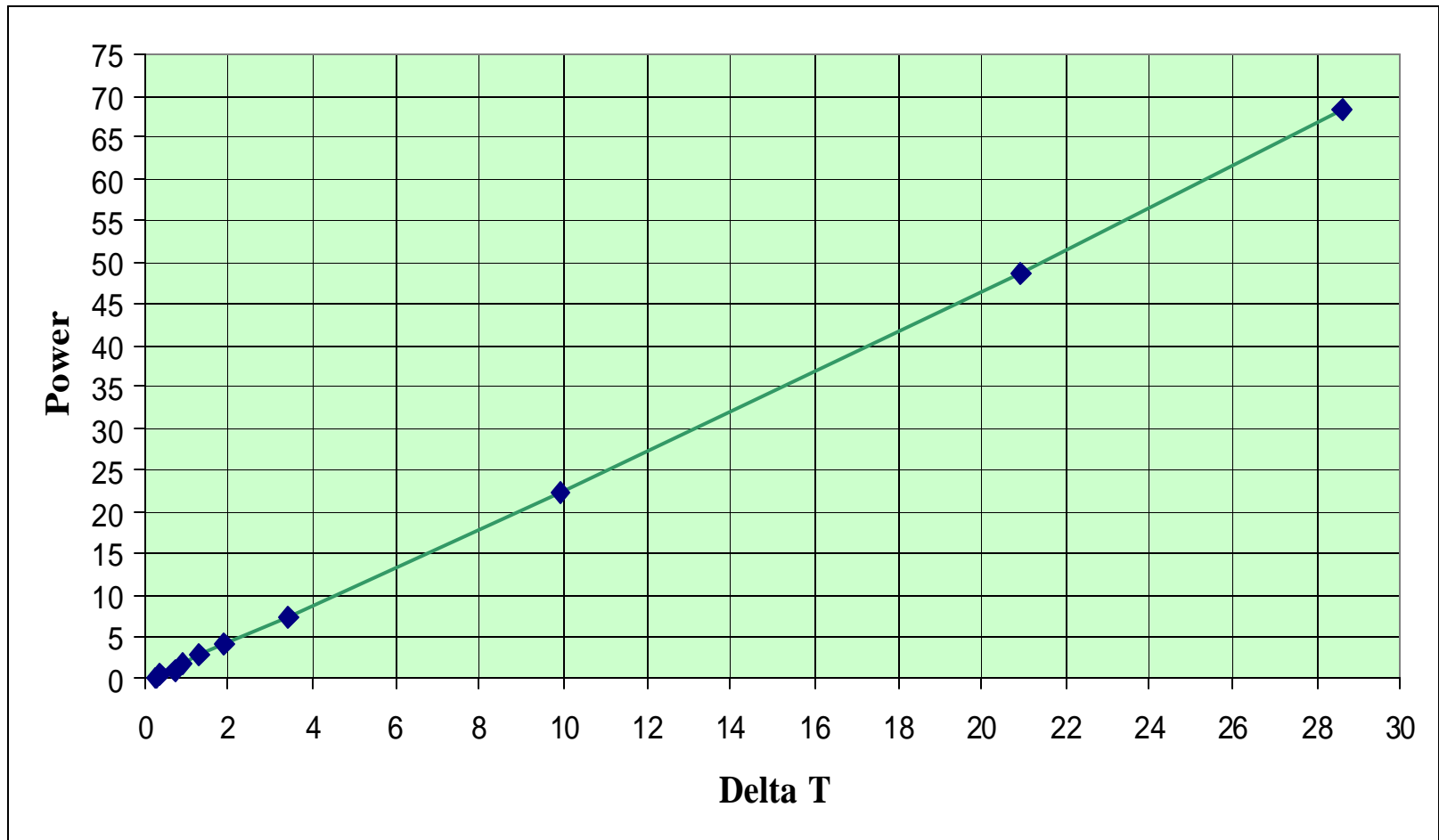

# Block diagram

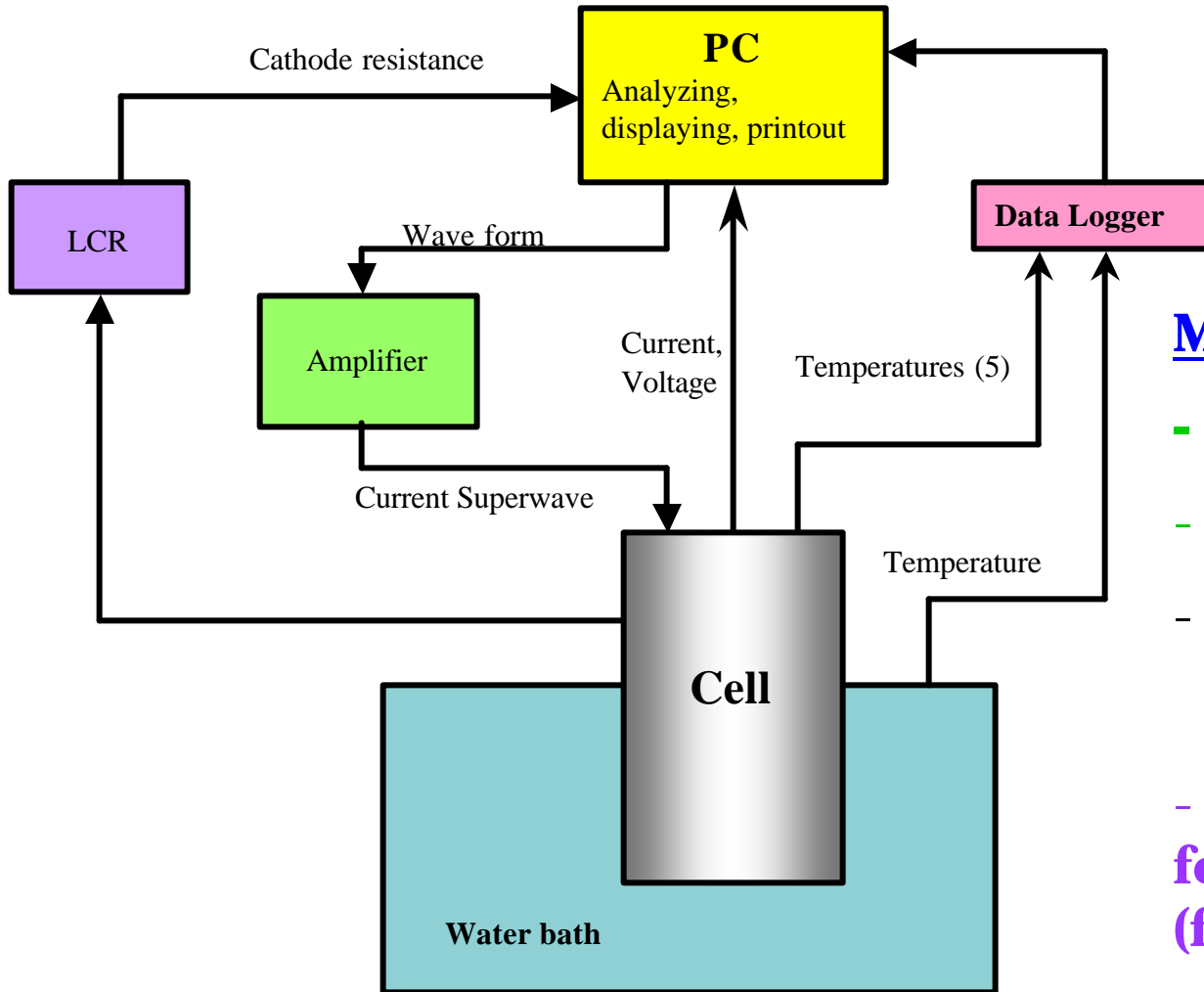

## Measured Parameters:

- **Input Current**
- **Input Voltage**
- **Wall Temperatures**  
 $T_4$  and  $T_5$
- **Resistance of cathode for monitoring loading (four probe AC method)**

# Study of Influence of Modulations on Loading

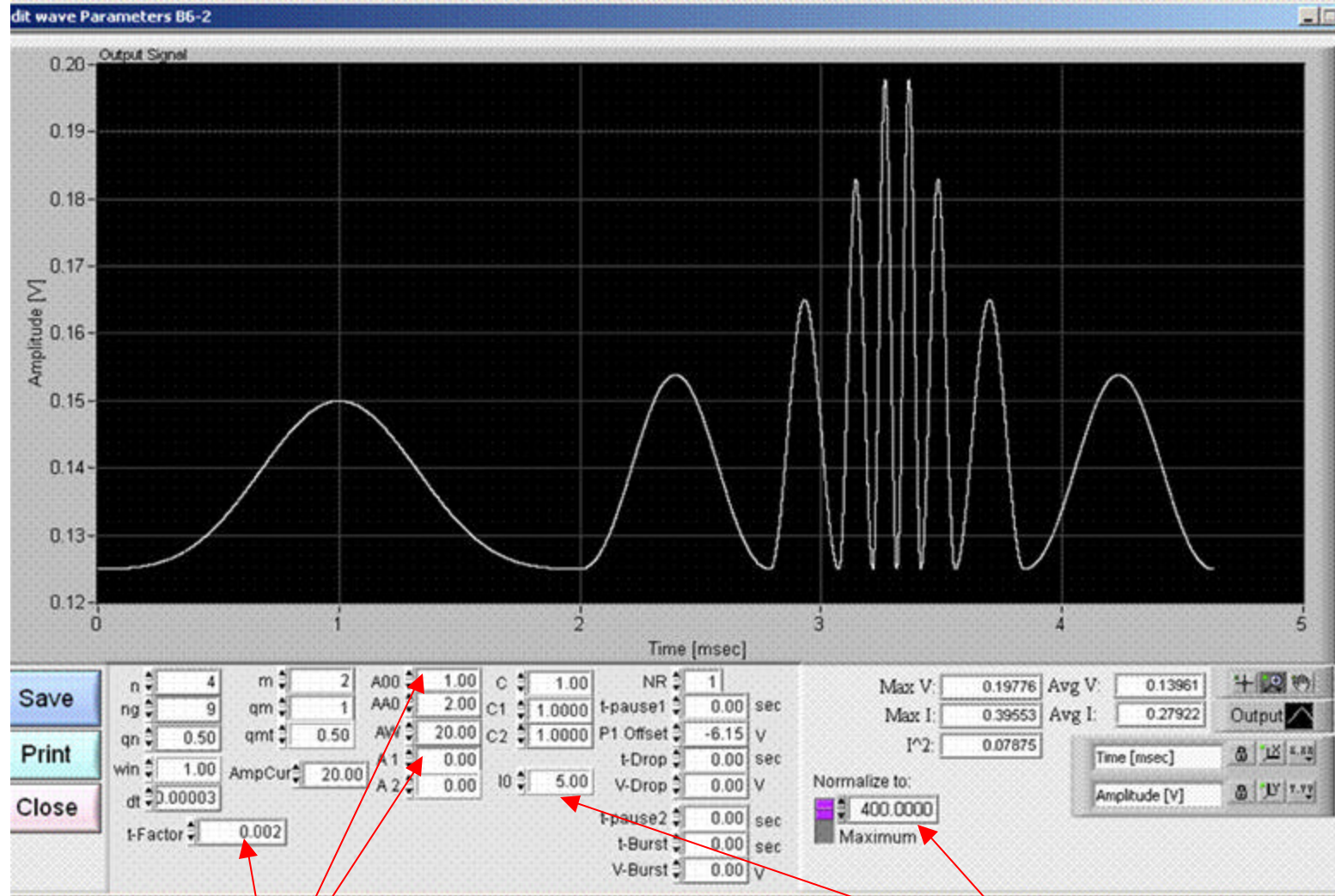

Changeable parameters

1<sup>st</sup> level of modulation

Constant parameters

# Study of Influence of Modulations on Loading

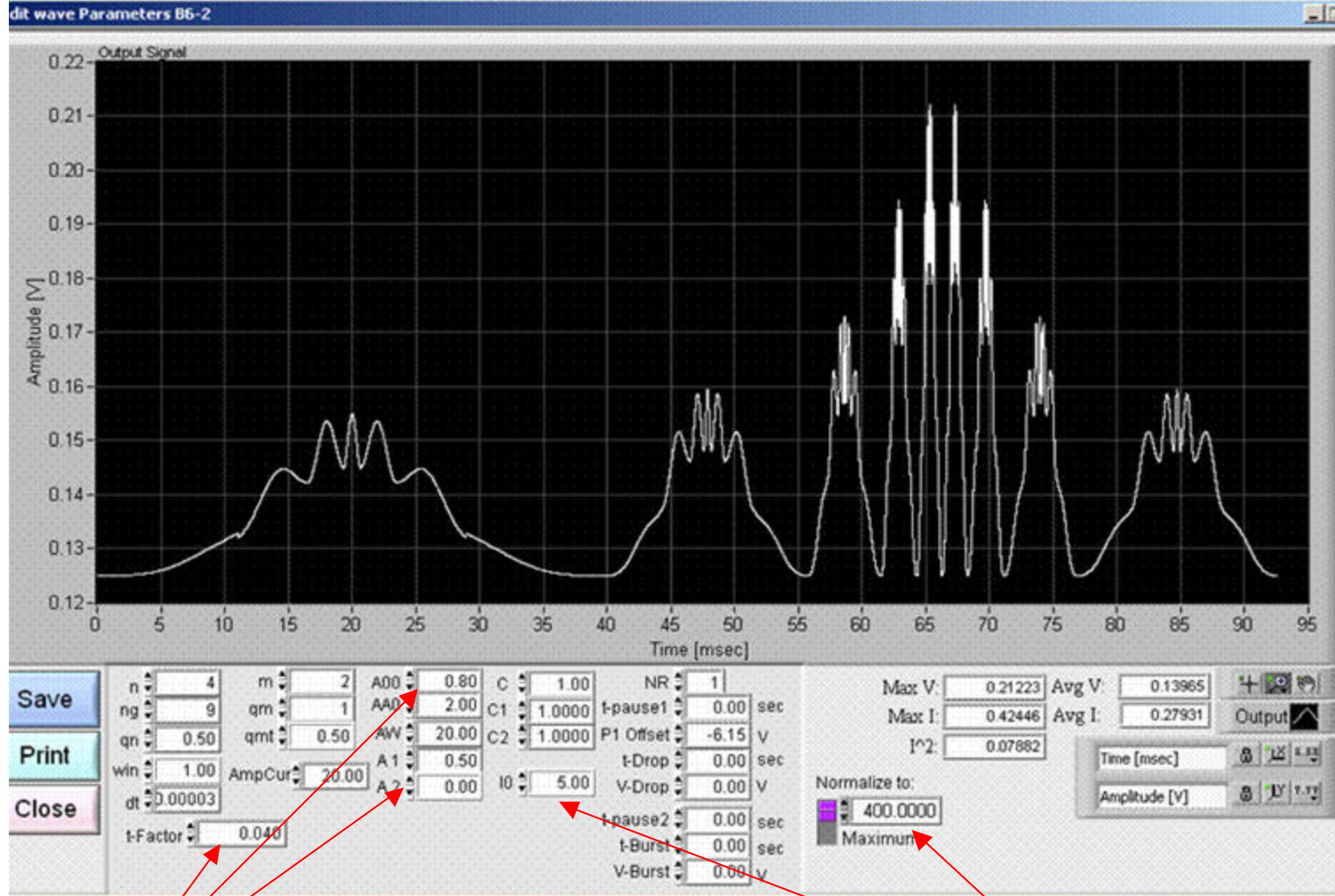

**Changeable parameters**

**2<sup>nd</sup> level of modulation**

**Constant parameters**

# Study of Influence of Modulations on Loading

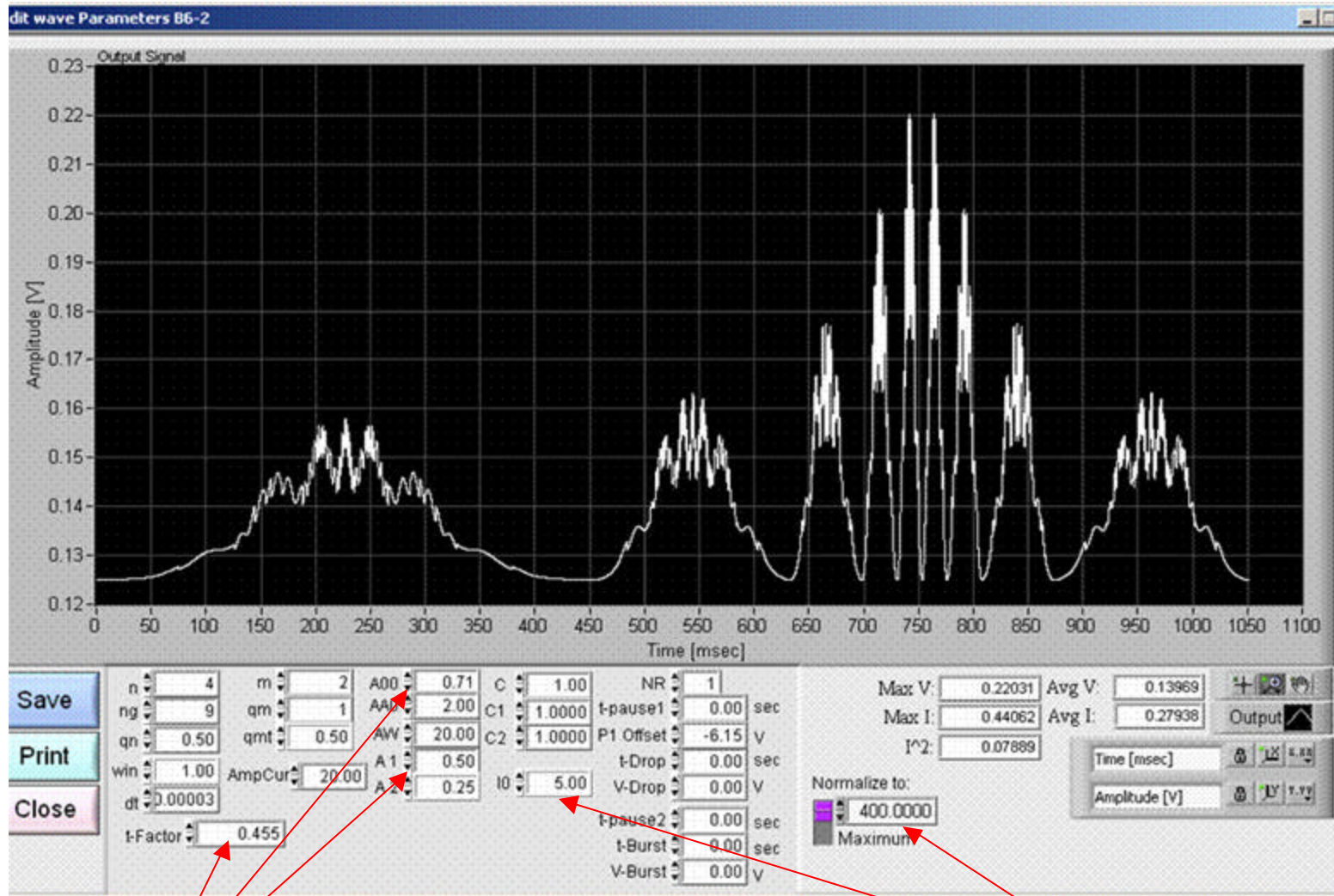

Changeable parameters

3<sup>rd</sup> level of modulation

Constant parameters

# Study of Influence of Modulations on Loading

1.

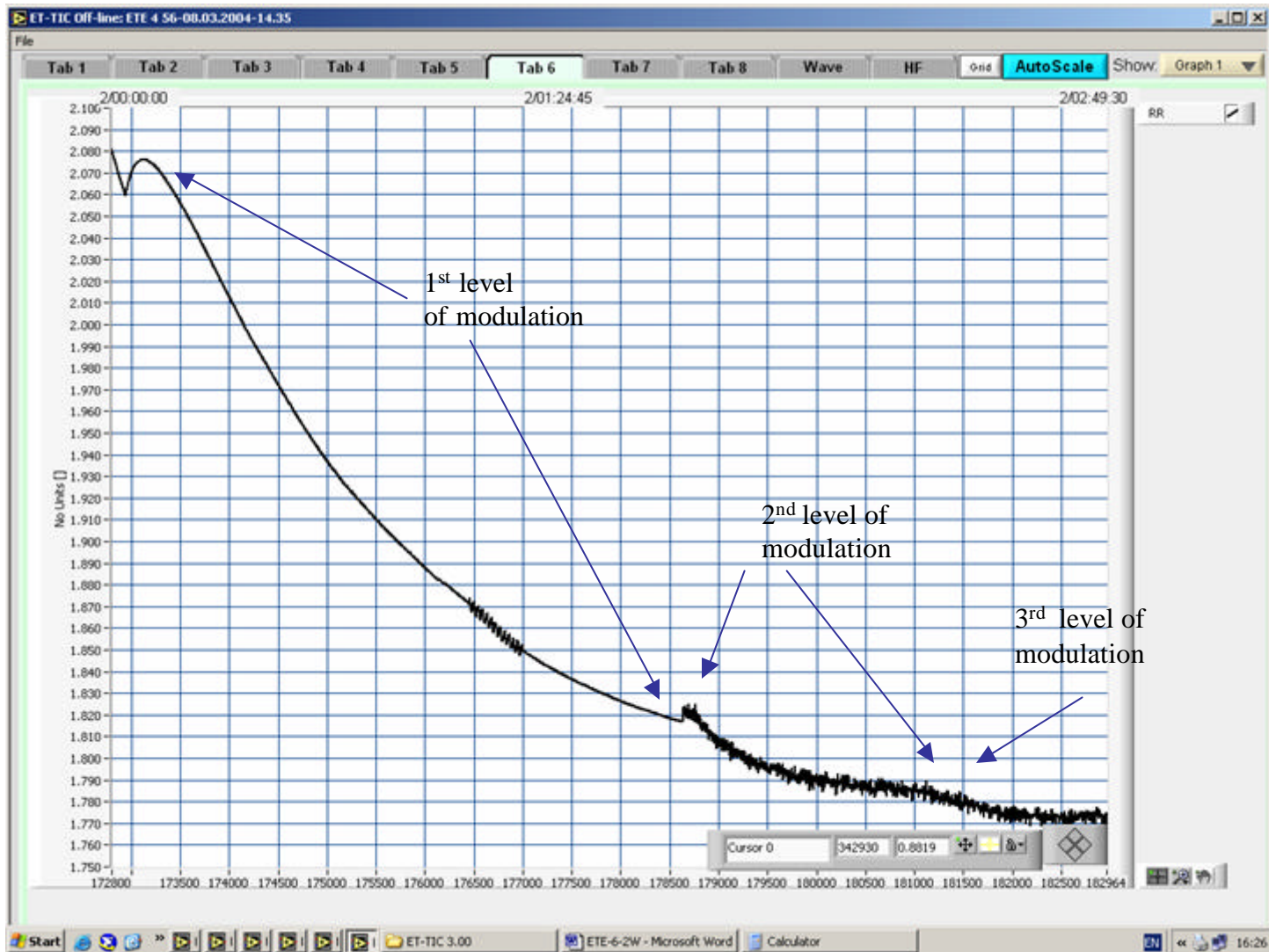

Of-line  $RR_0$  versus time for Foil N<sup>o</sup>56 (Dr. Violante)

# Study of Influence of Modulations on Loading

2.

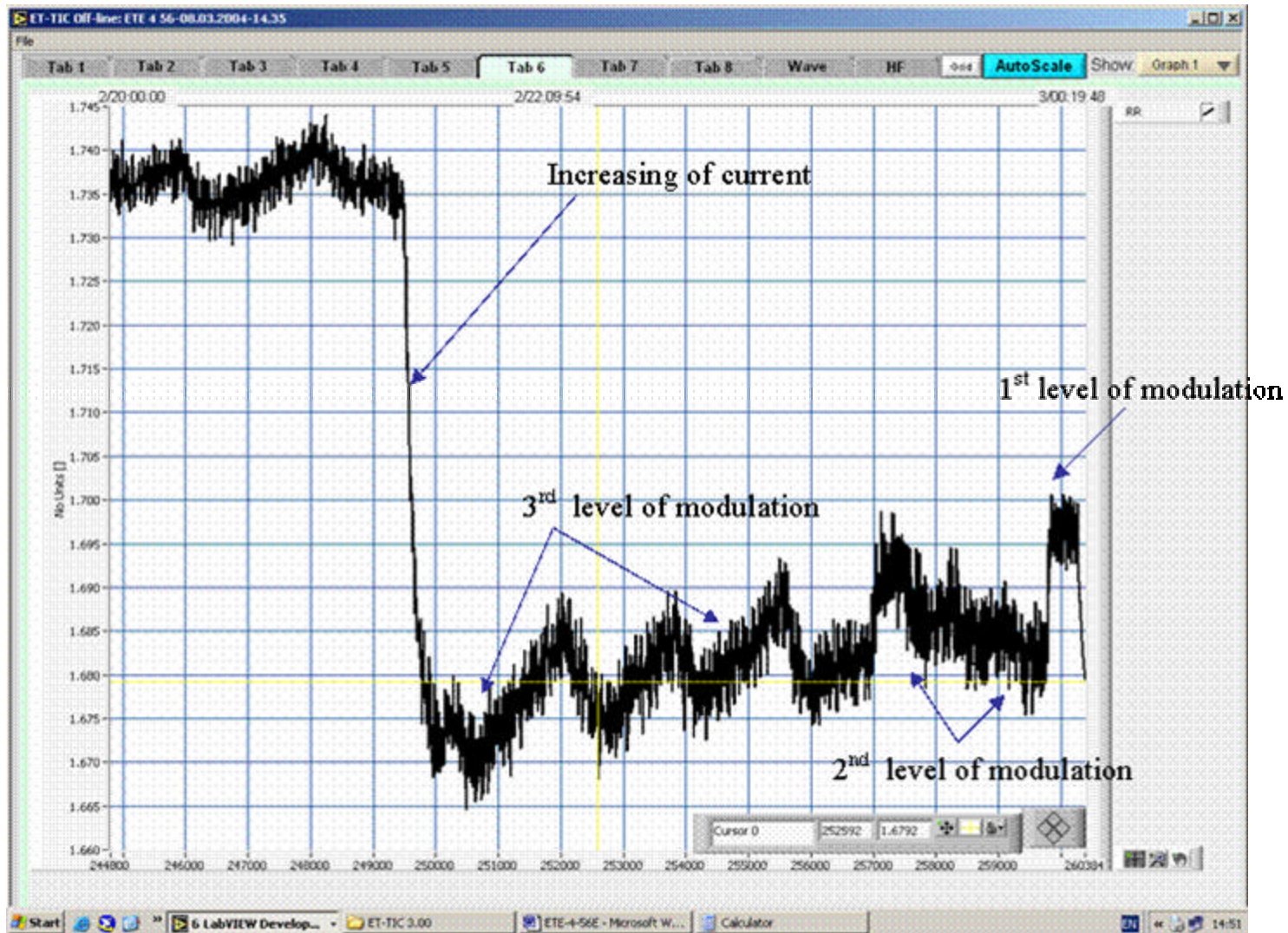

Of-line  $RR_0$  versus time for Foil N<sup>o</sup>56 (Dr. Violante)



# Study of Influence of Modulations on Loading

3.

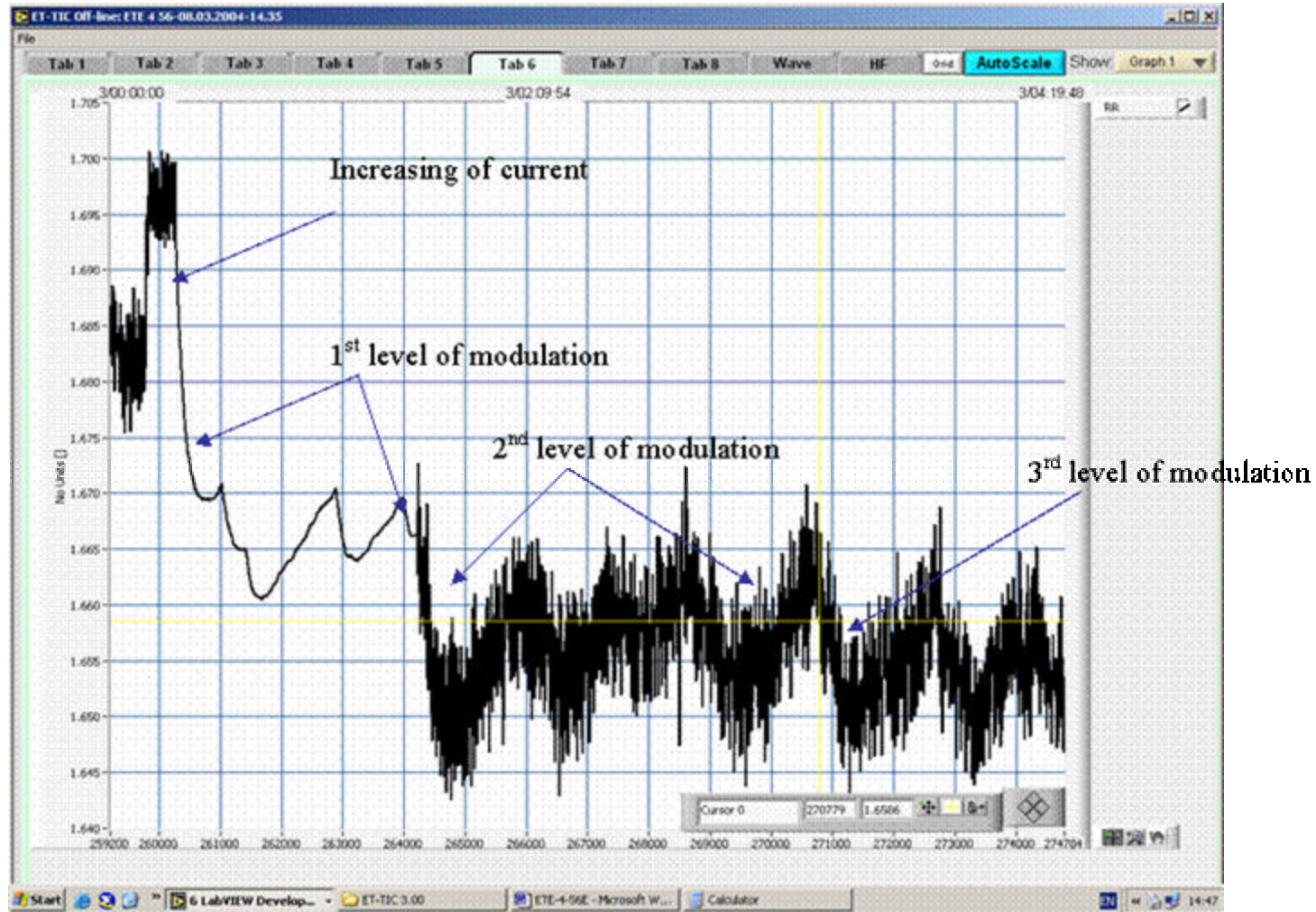

Of-line  $RR_0$  versus time for Foil N°56 (Dr. Violante)

# Study of Influence of Modulations on Loading

## Diagram loading versus level of modulation

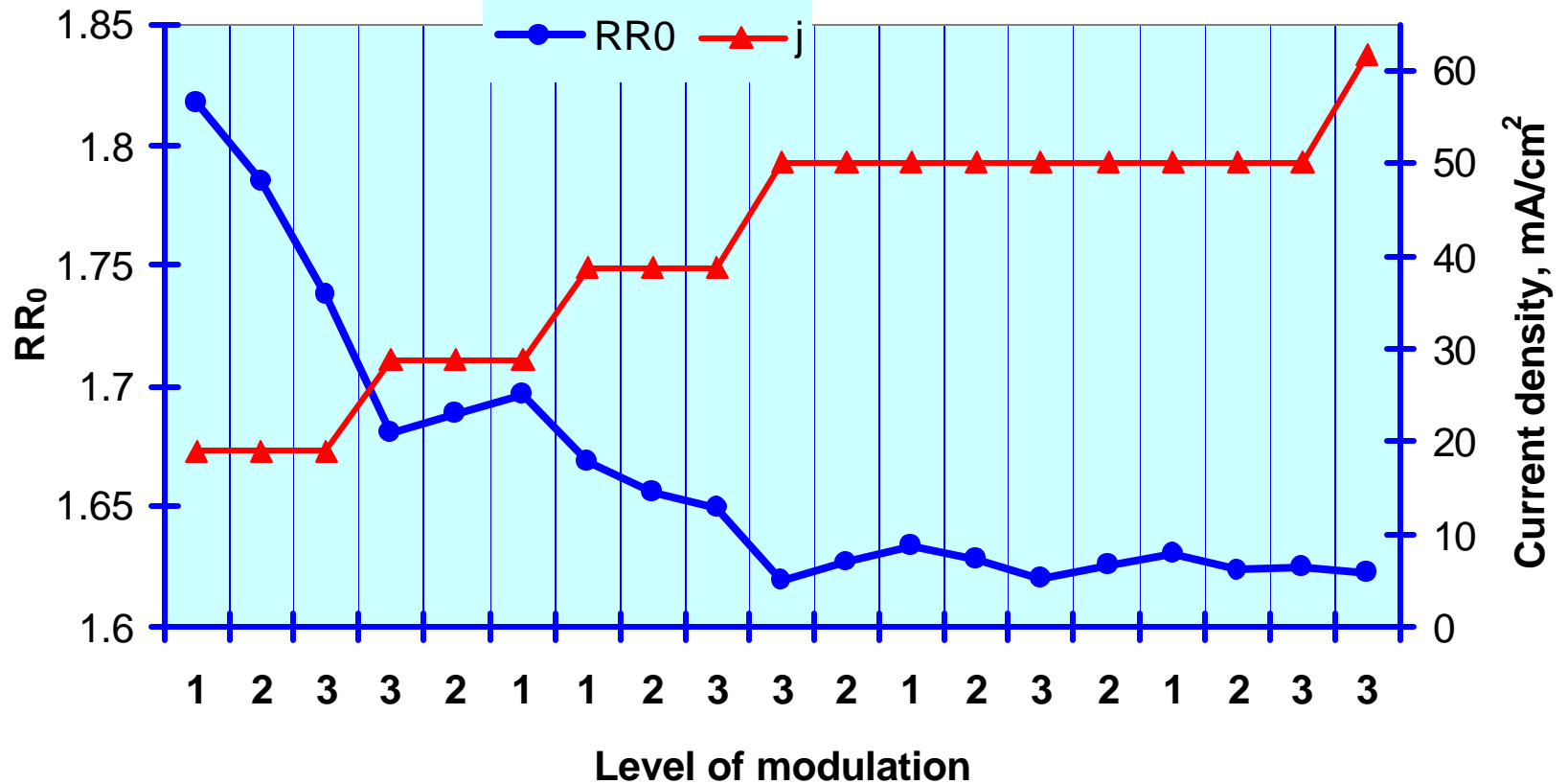

# Study of Influence of Modulations on Loading

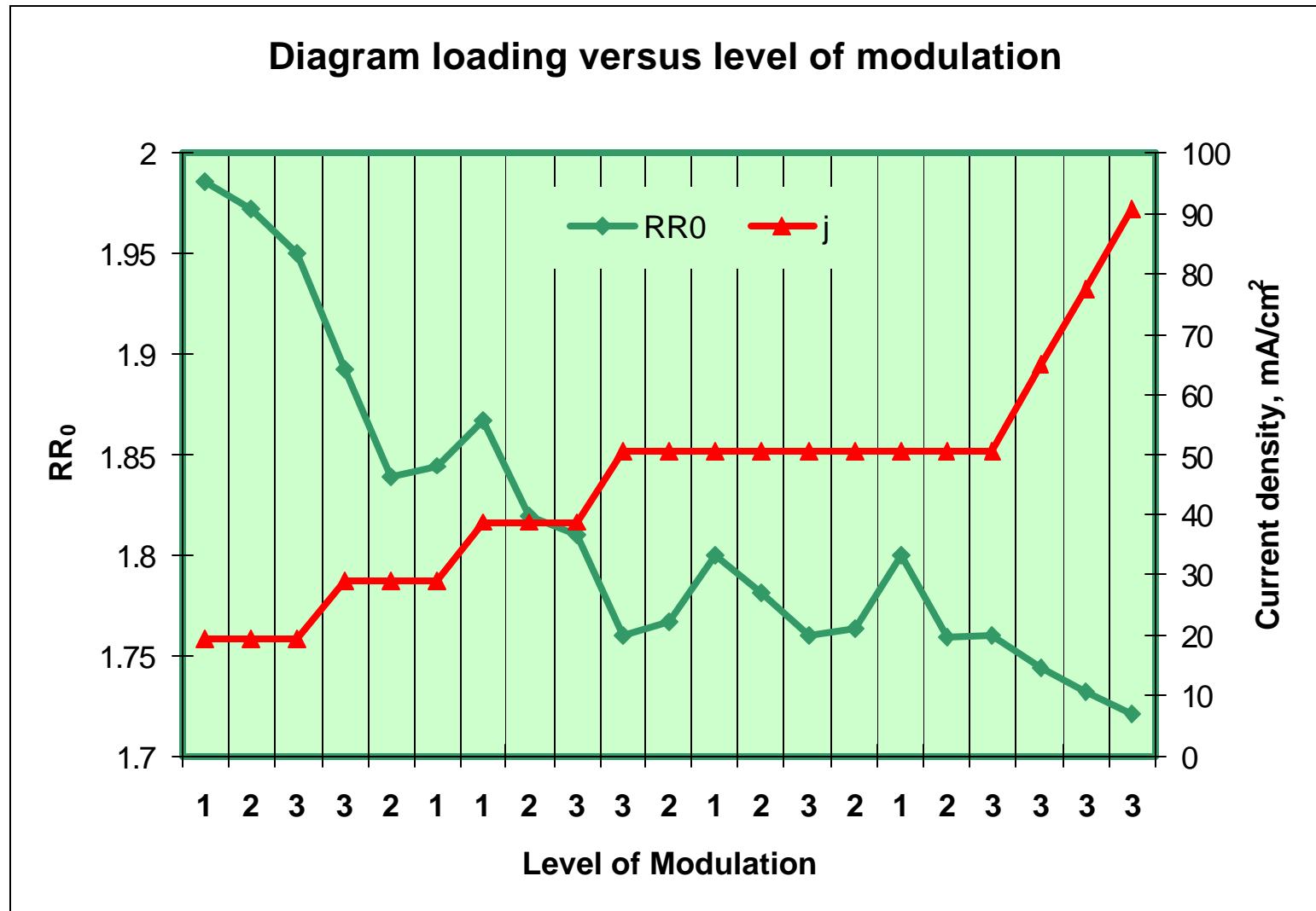

# Excess Power; Exp. # 56

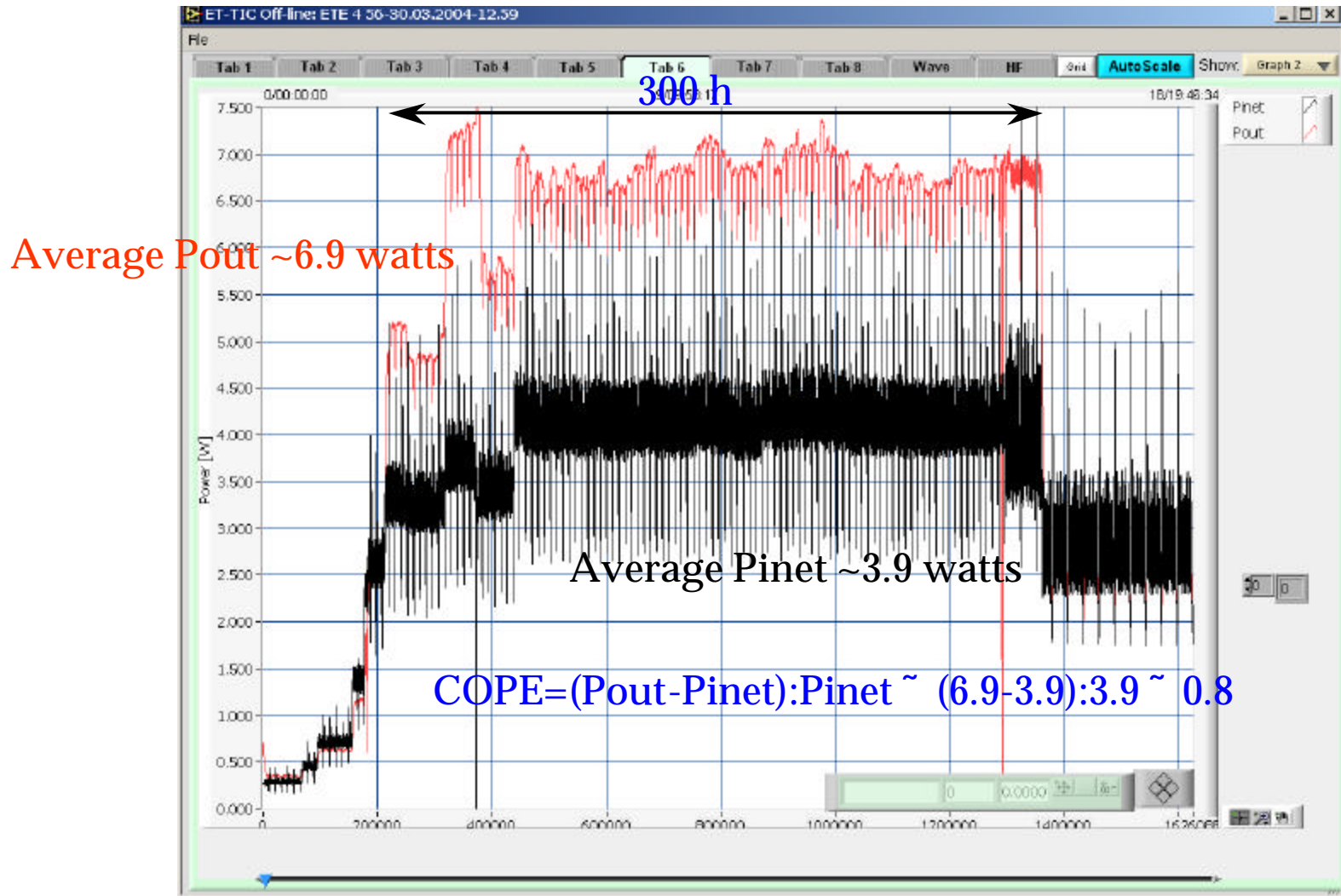

Excess Power of up to ~3.5 watts; Average ~2.7 watts for ~300 h 28

# Excess Energy; Exp. # 56

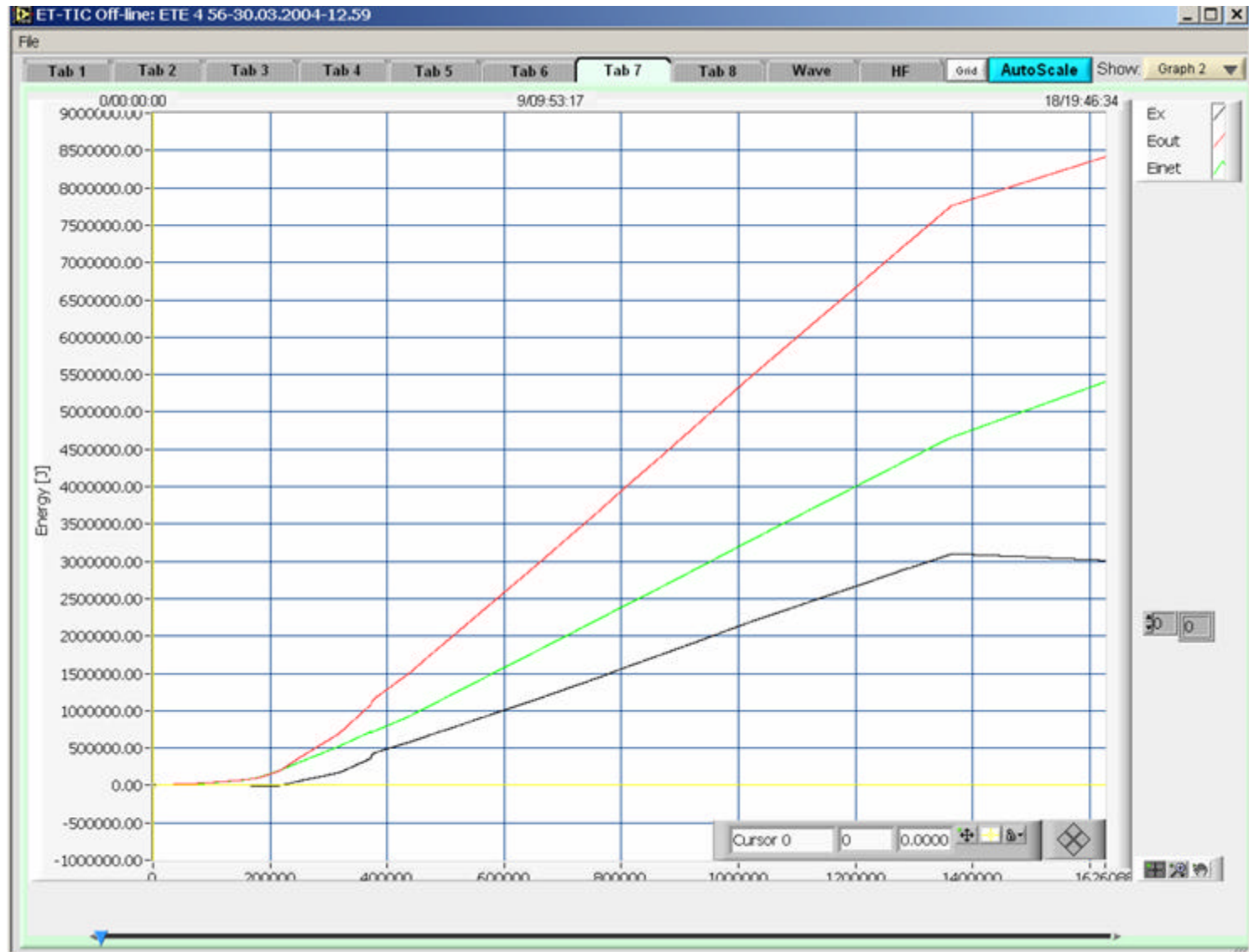

Excess energy of ~3.1 MJ

# Excess Power; Exp. # 64a

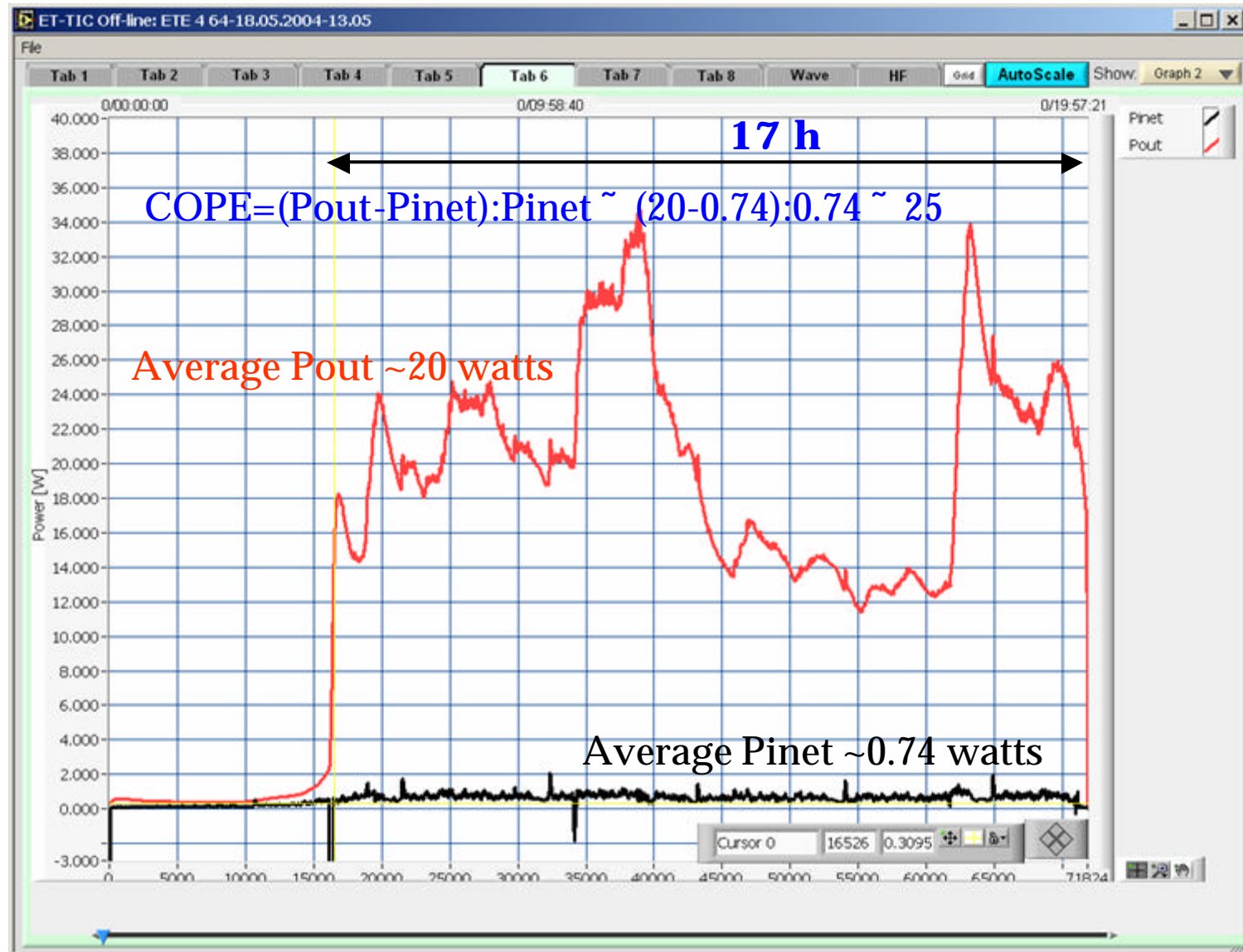

Excess Power of up to 34 watts; Average ~20 watts for 17 h

# Excess Energy; Exp. # 64a

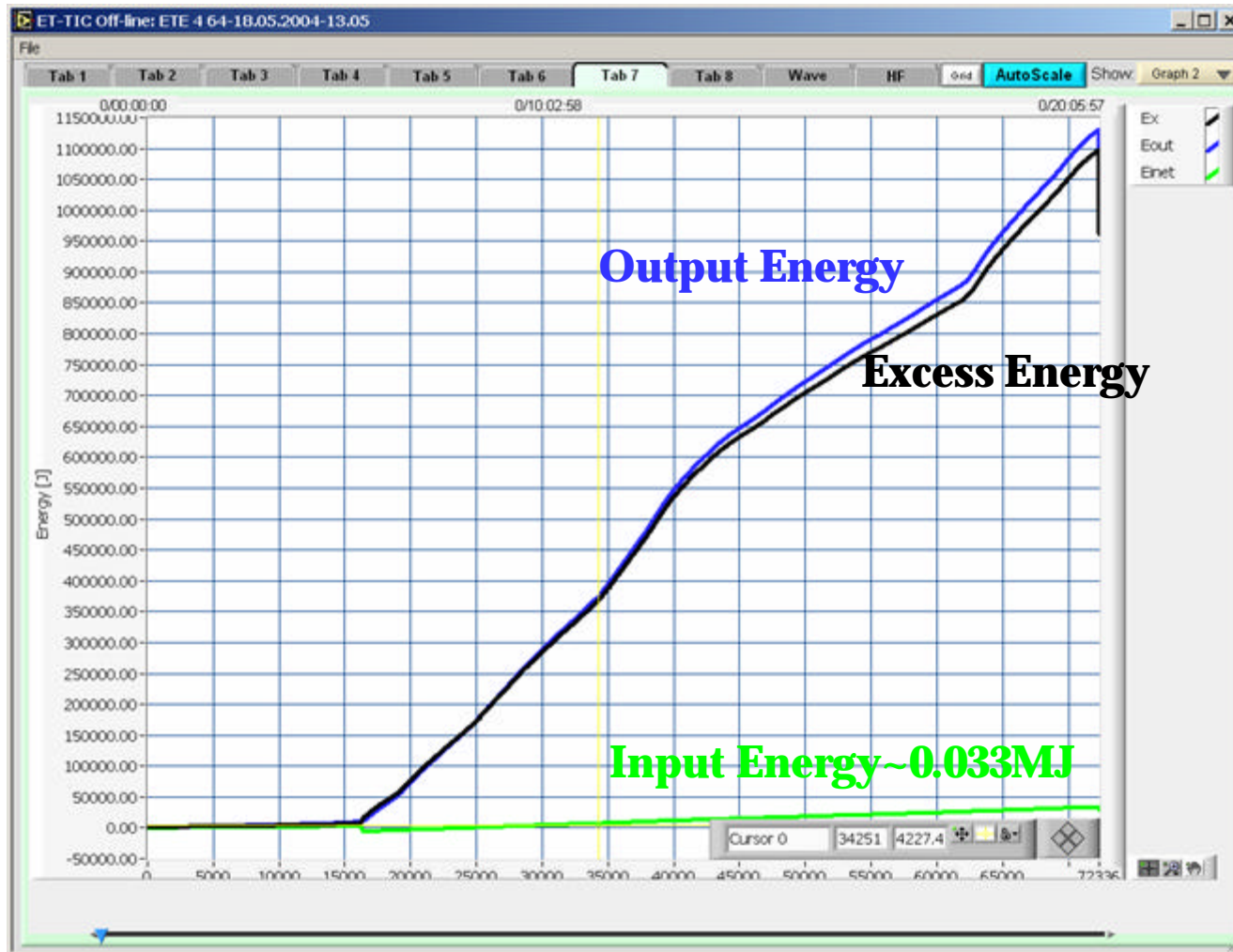

Excess energy of  $\sim 1.1$  MJ

# Temperature Evolution, Exp. # 64a

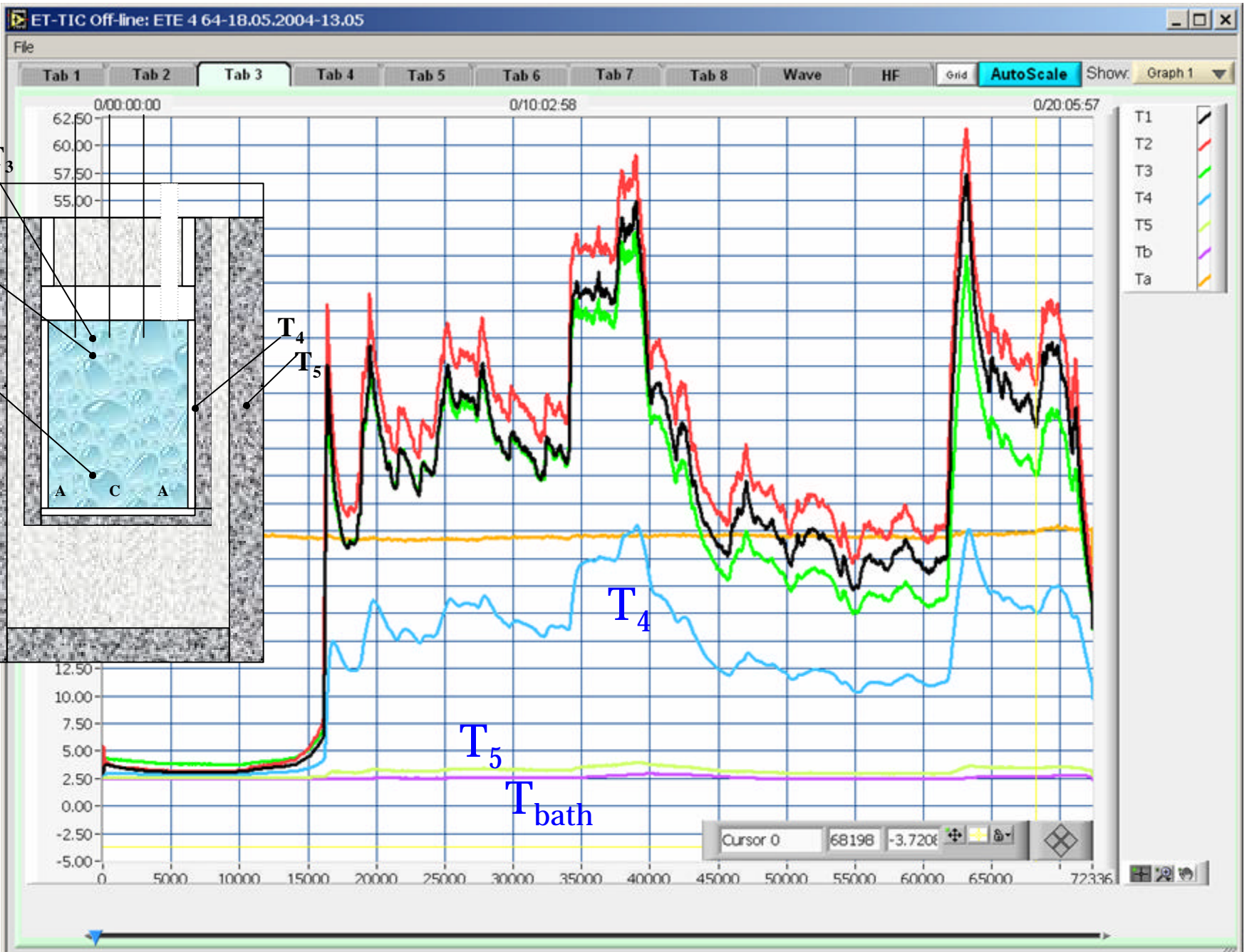



# Current & Voltage; EXP. # 64a

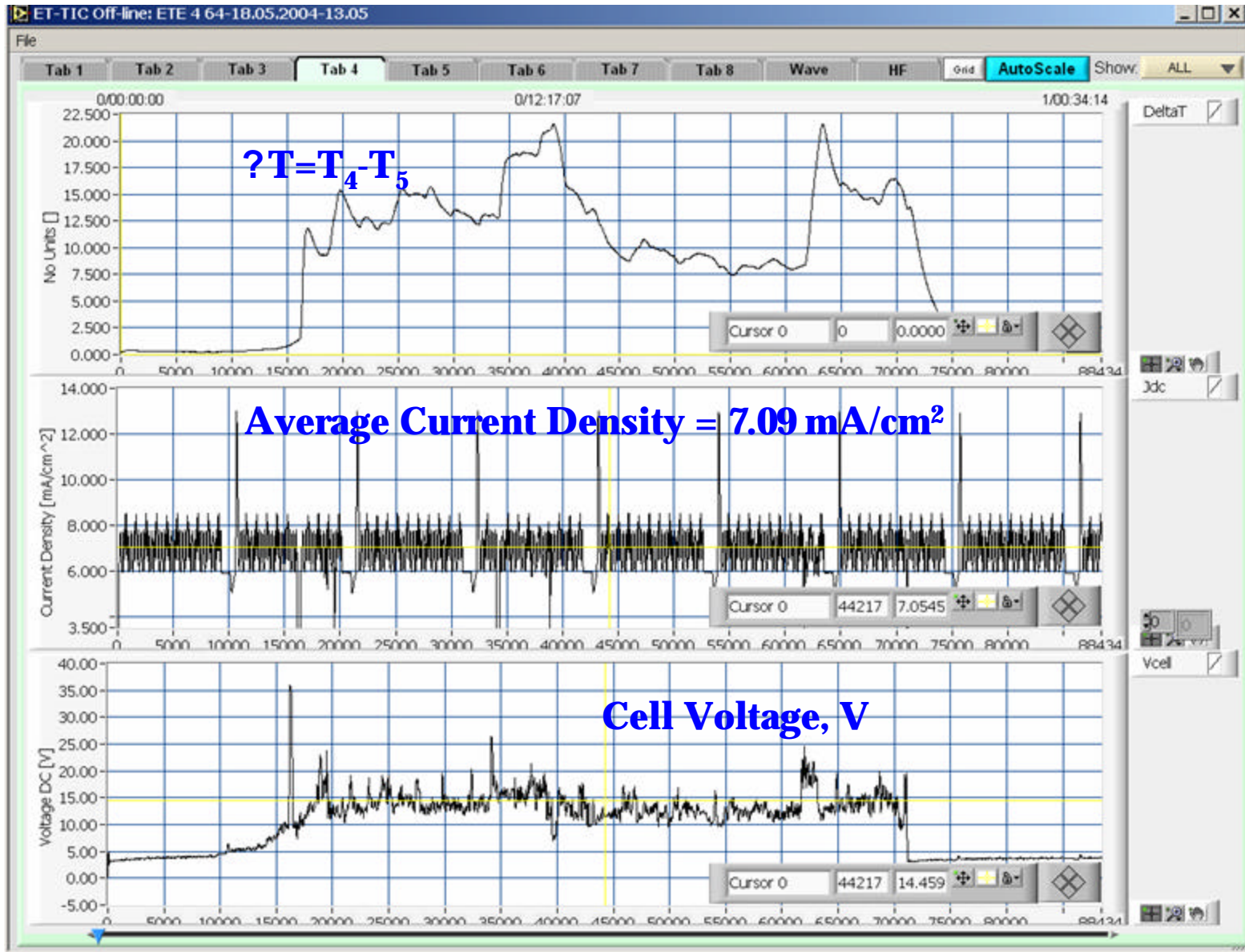

# R/Ro & Power; EXP. # 64a



Loading is relatively low ( $\sim 0.8$ )

# Excess Power; Exp. # 64b

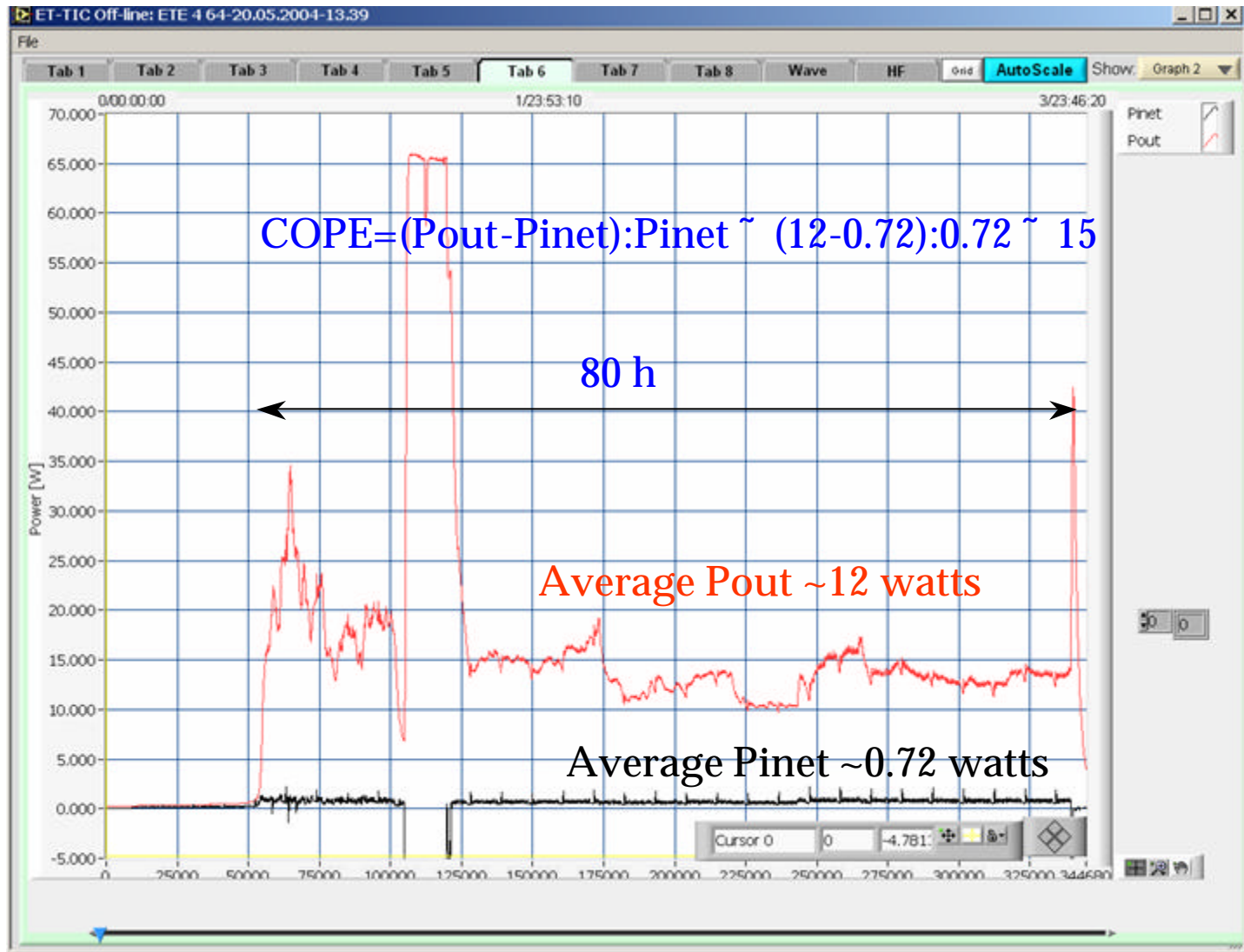

Excess Power of up to 32 watts; Average ~12 watts for 80 h

# Excess Energy; Exp. # 64b

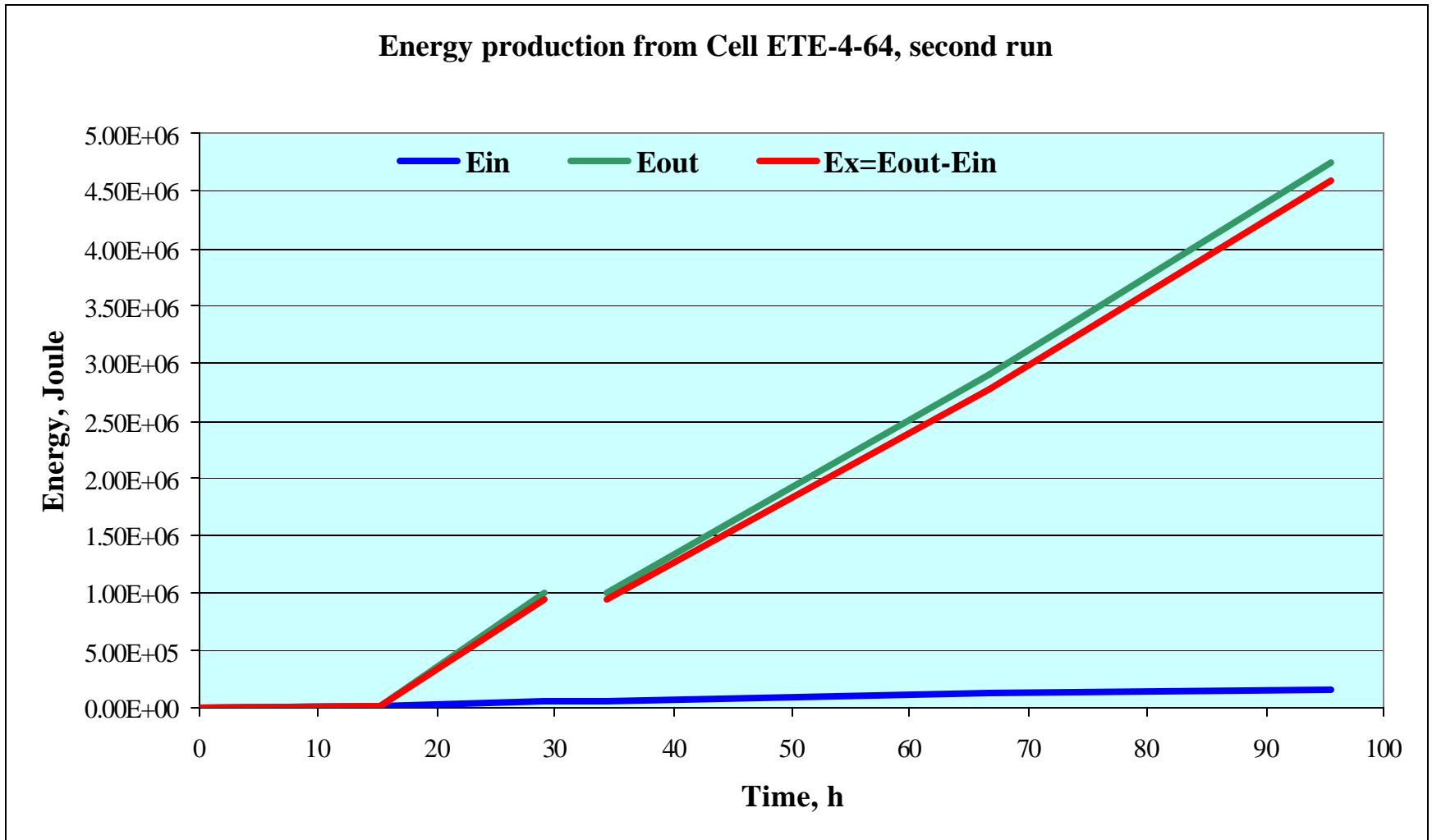

Excess energy of ~4.6 MJ

# Temperature Evolution, Exp. # 64b

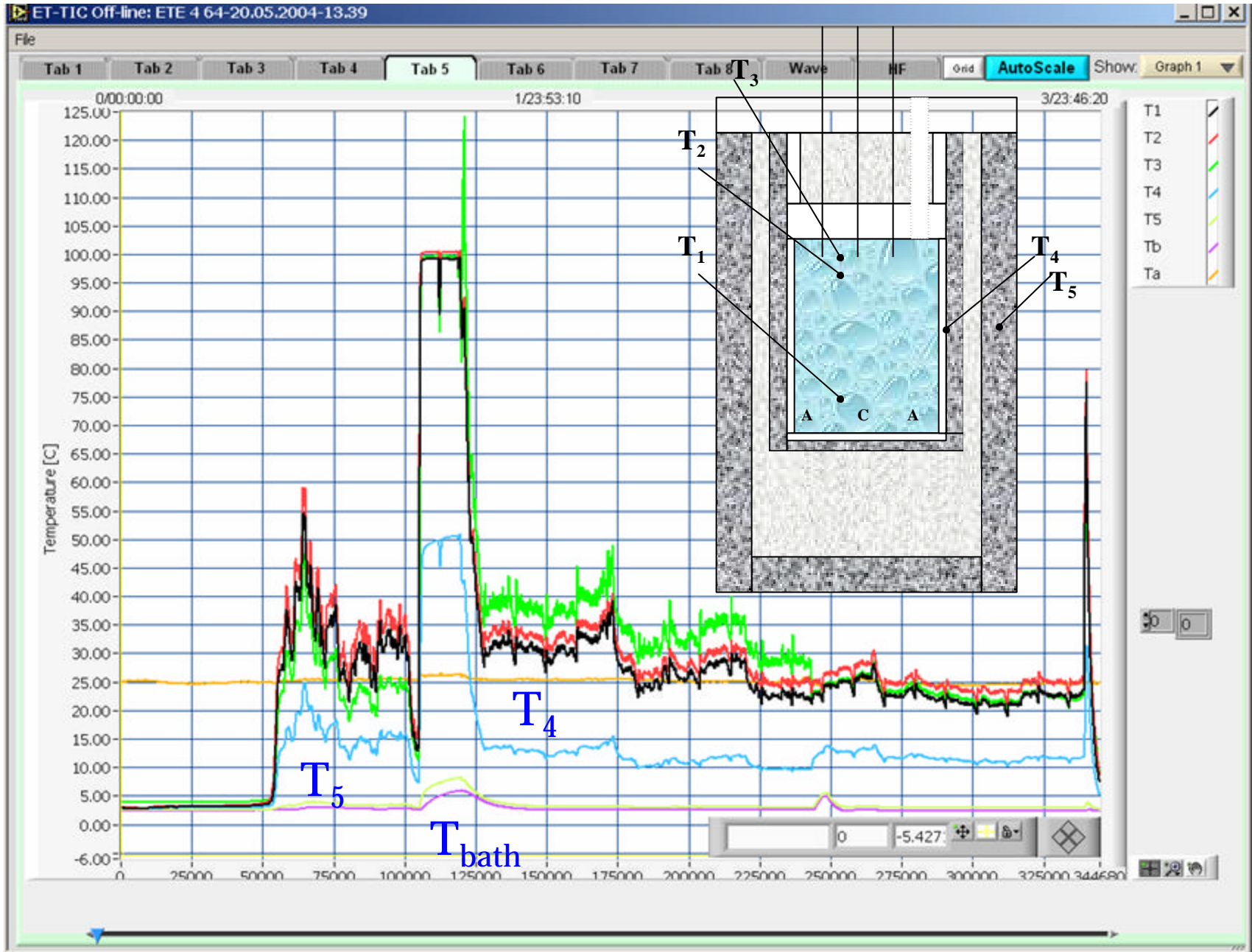

# ?T, Current Density & Voltage ; EXP. # 64b

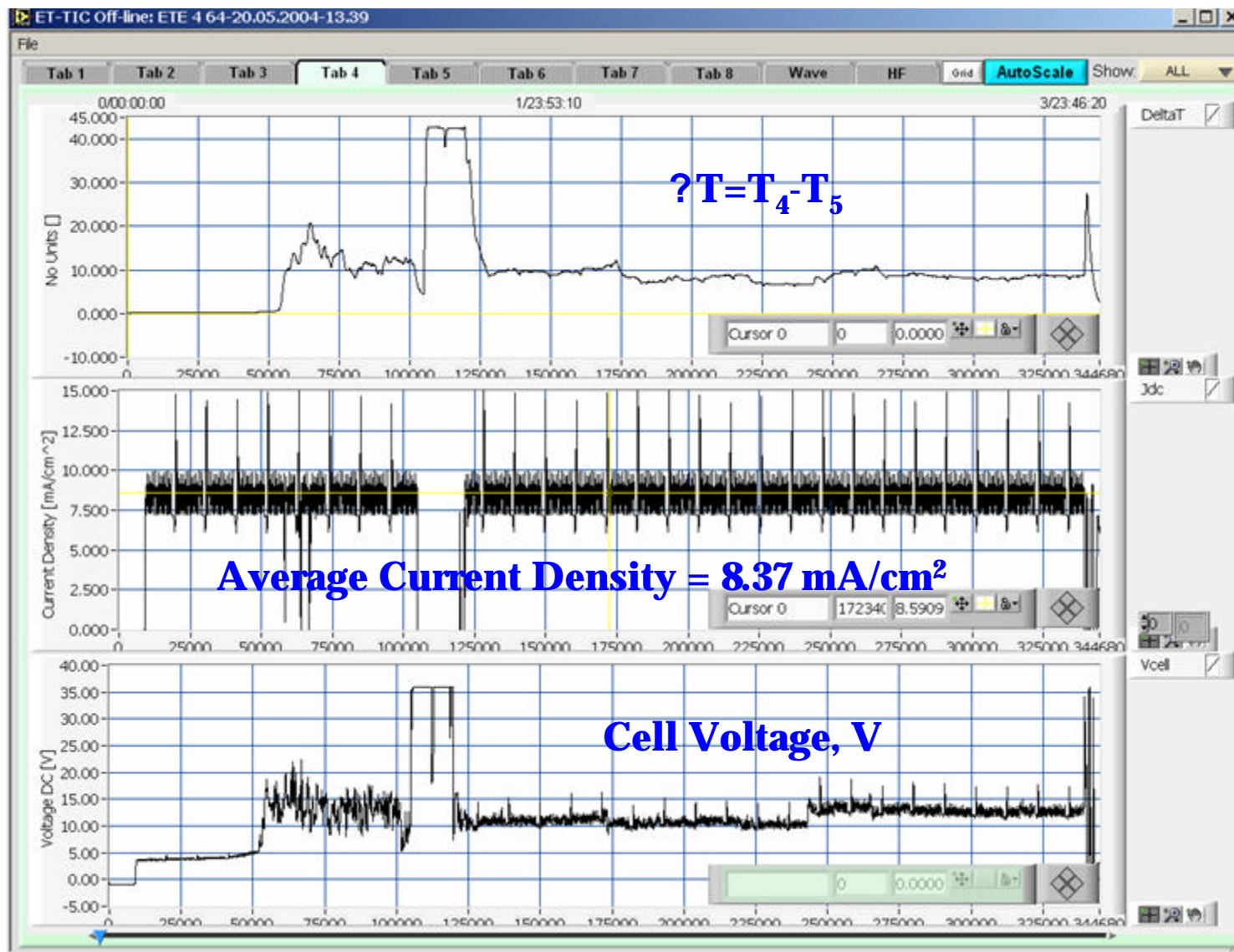

# R/Ro & Power; Exp. # 64b

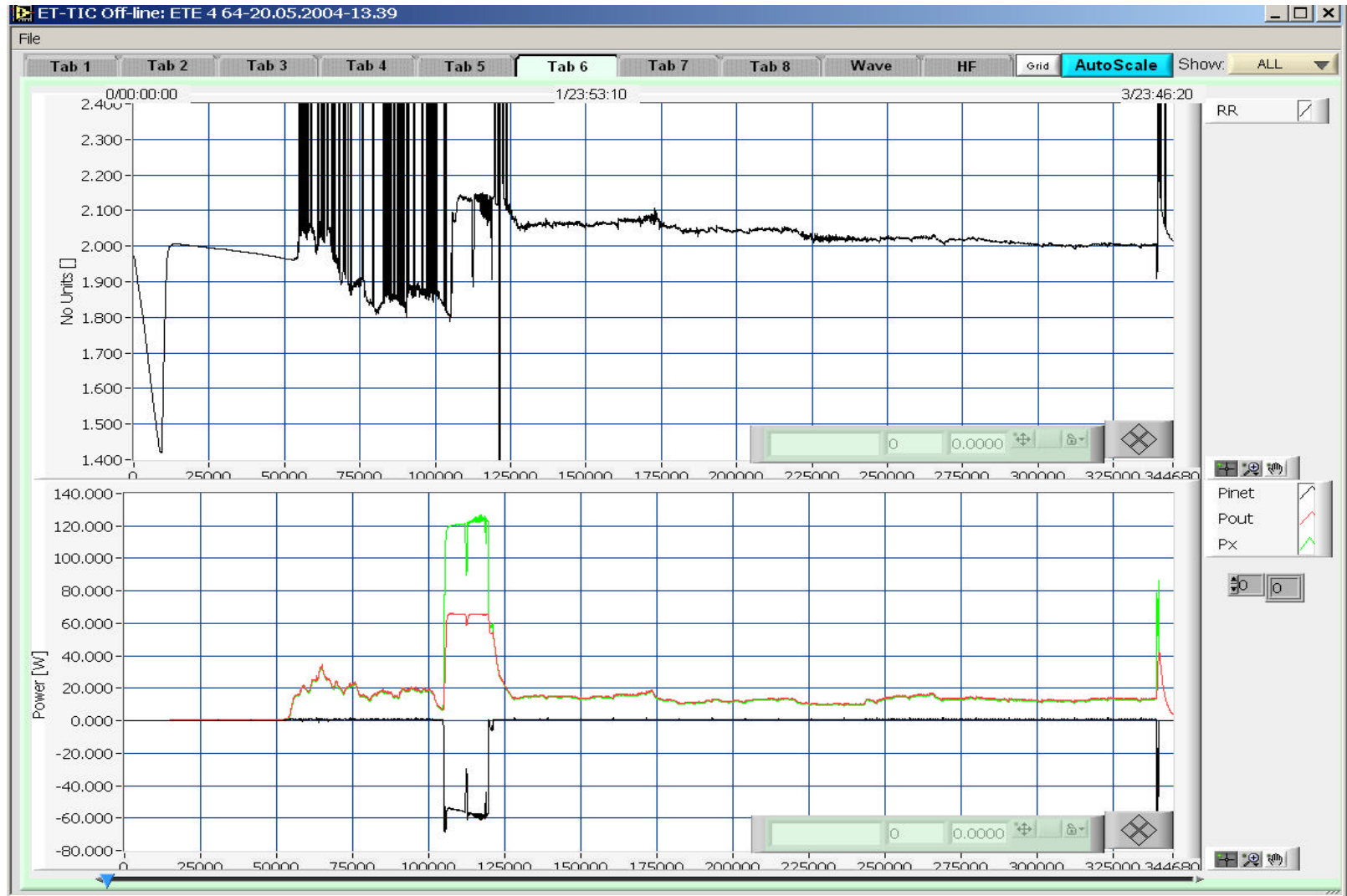

Loading relatively low ( $\sim 0.8$ )

## Excess Tritium in # 64

- Tritium concentration measured at end of #64 analysis ~ 250% of reference
- ~625 cm<sup>3</sup> of D<sub>2</sub>O has been added to make-up for evaporation; initial inventory was 230 cm<sup>3</sup>
- Assuming TDO/D<sub>2</sub>O evaporation rate ~ 1.0
- Estimated T effective concentration ~ 750%
- This amount of tritium corresponds to <1J – negligible as compared with the 5.7MJ excess energy generated.



# Material Analysis

## Diagnostics:

- Auger Electron Spectrometry
- Scanning Electron Microscopy-Energy Dispersive Spectrometry SEM-EDS
- Transmission Electron Microscopy (TEM)
- Secondary Ion Mass Spectrometry (SIMS)

# Material Analysis # 64 vs. 63; SEM-EDS

Surface of Pd foil after rolling and annealing at 870°C:

sample #64

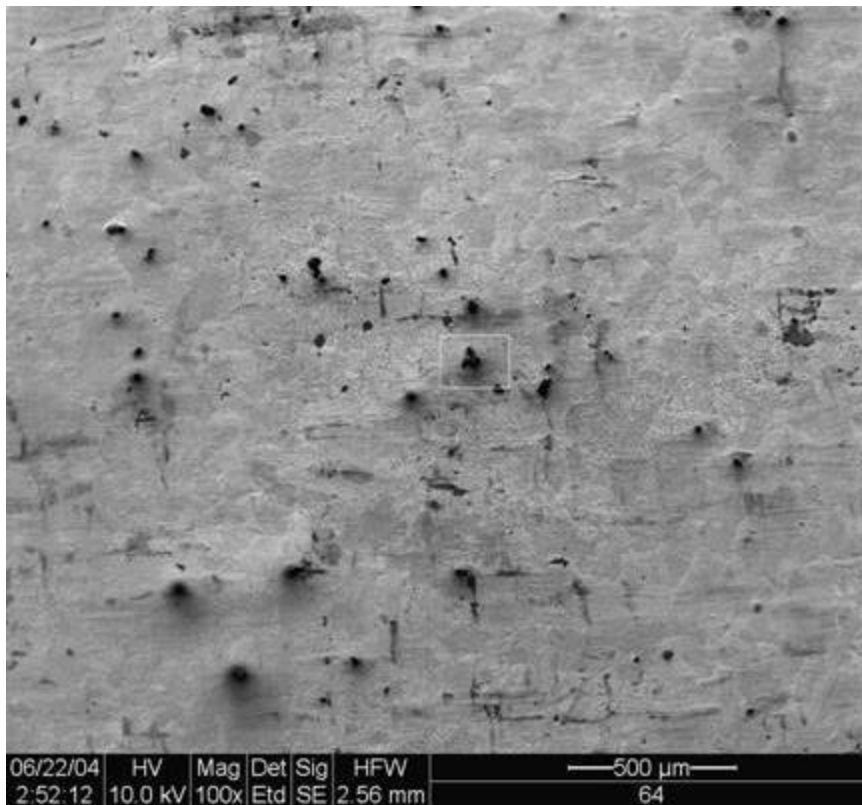

sample #63

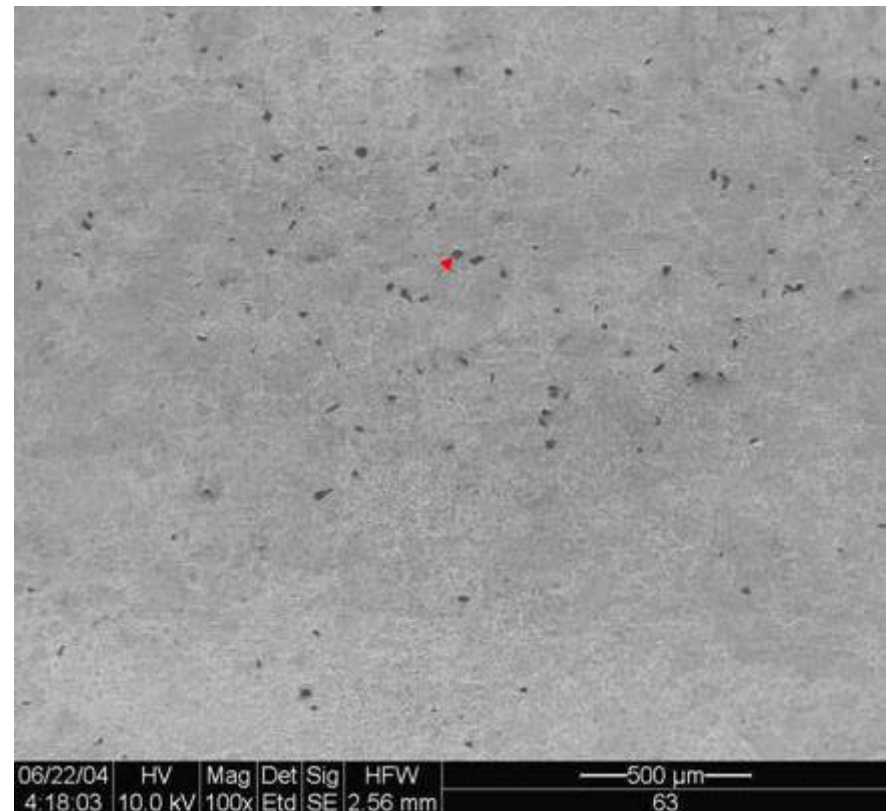

# View of Typical Black Spot on # 64 and its composition

## SEM-EDS

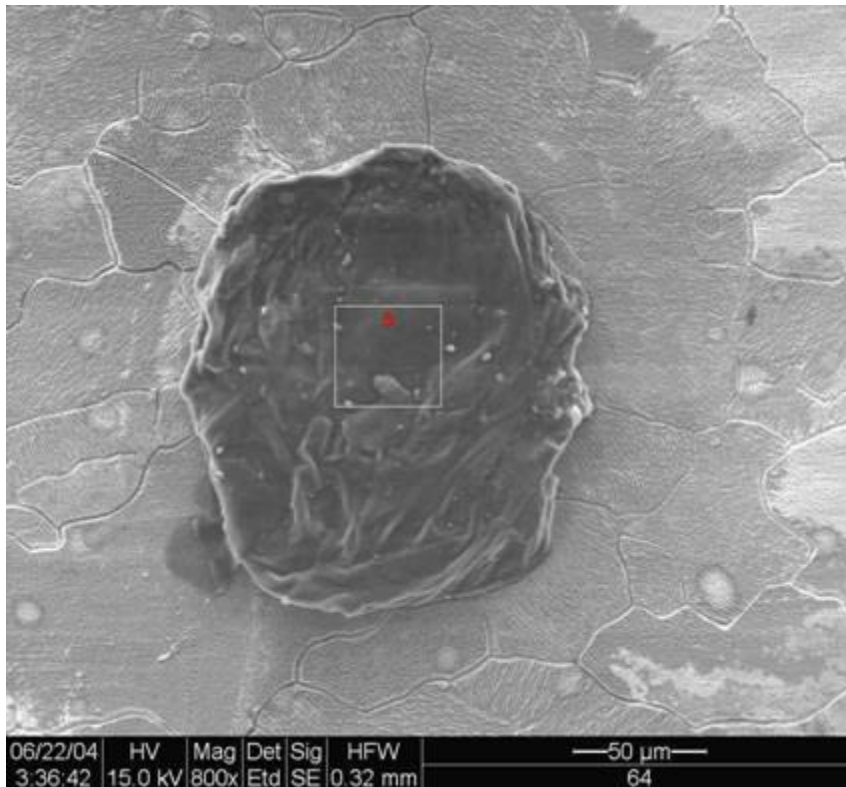

Element	Wt %	At %
C	35.77	52.48
O	26.19	28.84
Na	4.92	3.77
Al	0.43	0.28
Si	1.05	0.66
Pt	0.39	0.04
S	1.44	0.79
Cl	10.68	5.31
Pd	2.55	0.42
K	11.07	4.99
Ca	5.52	2.43
Total	100.00	100.00

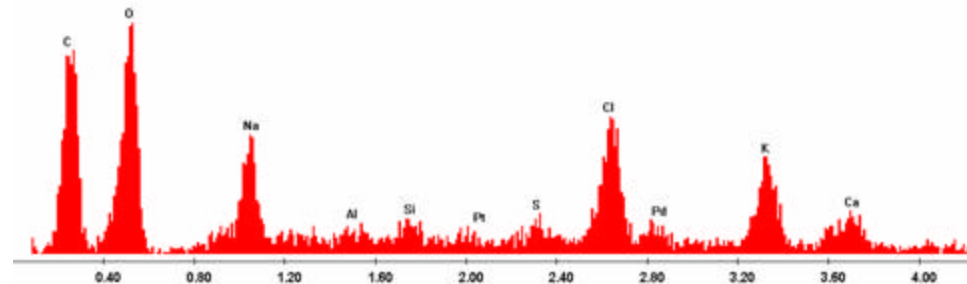

# AES profiles of Pd, C, O and Cl of Pd foils #63 and # 64

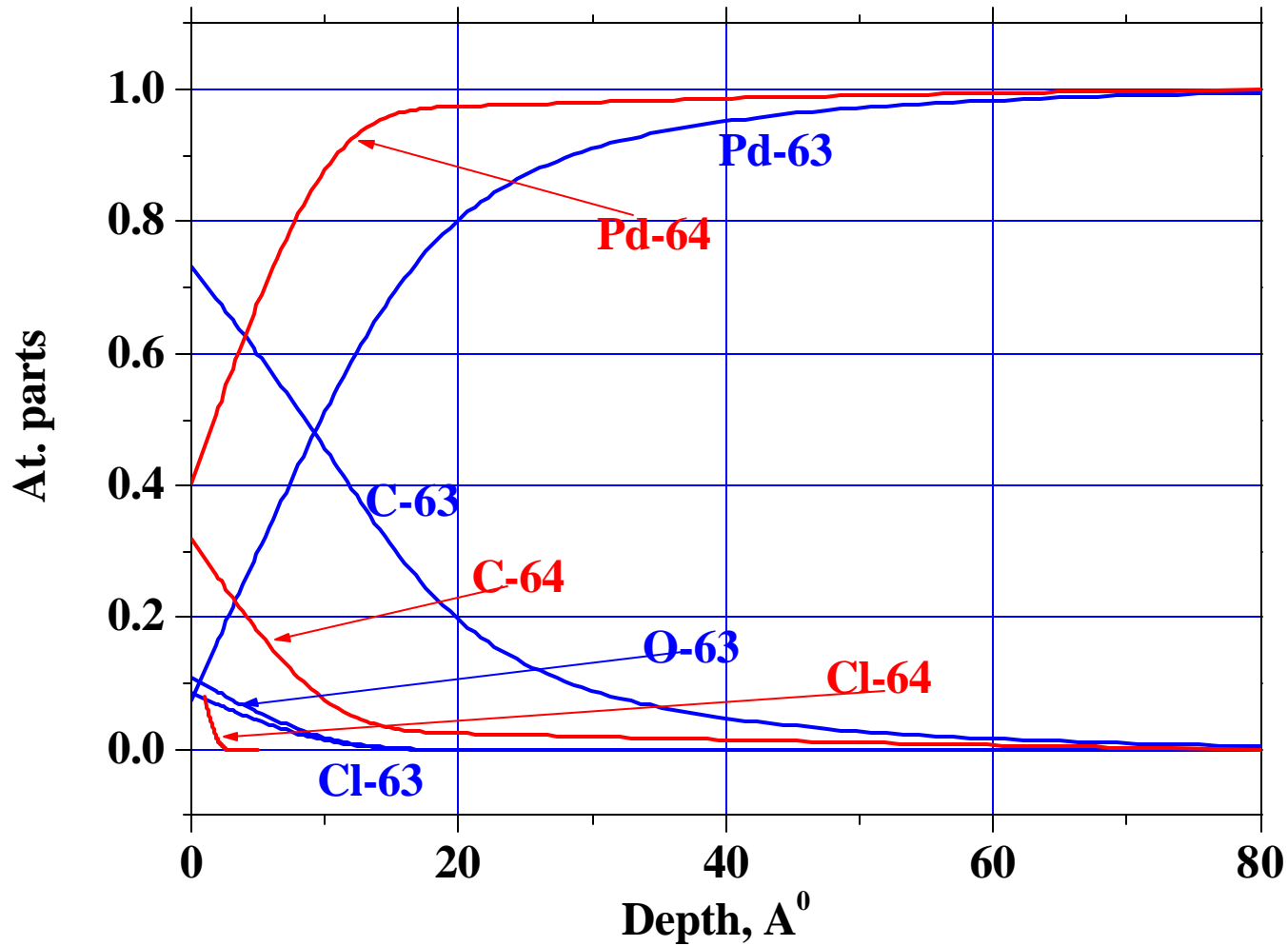

After etching in Aqua Regia

# Sample 64. SIMS depth profiling.

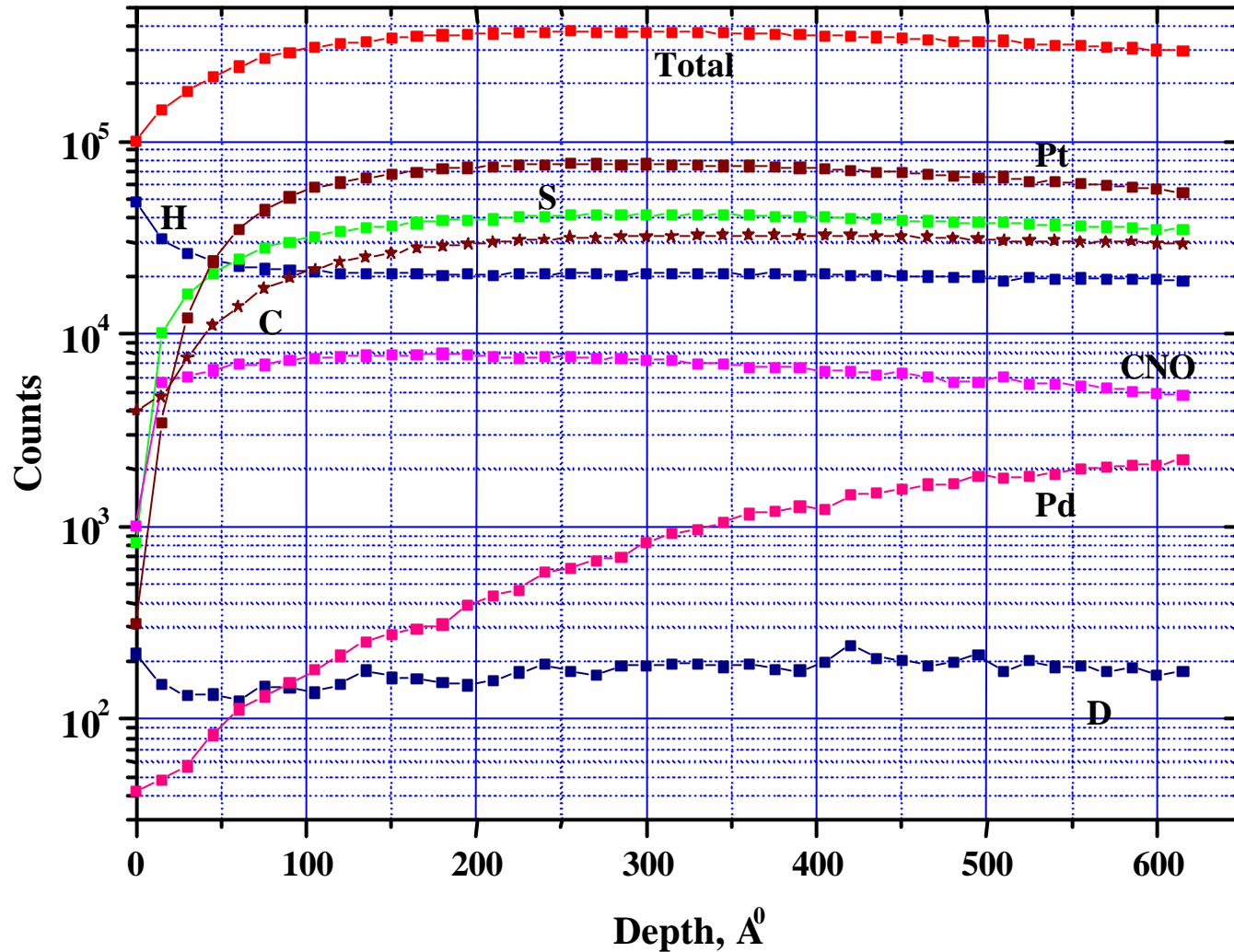

Spatial distribution of selected isotopes measured by SIMS in #64  
a – D, b -  $^{32}\text{S}$ , c - total isotopes content, d -  $^{195}\text{Pt}$ .  
Scale bar - 30  $\mu\text{m}$ .

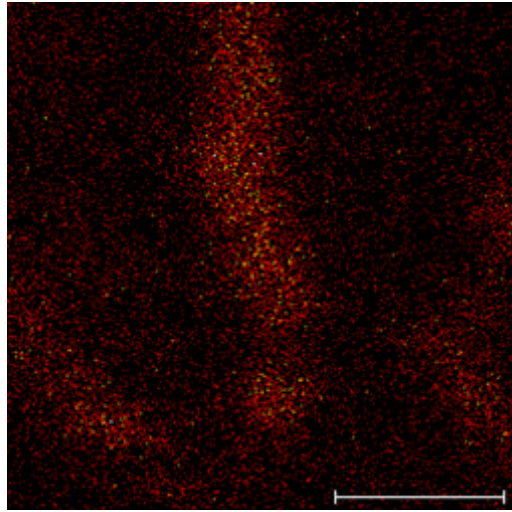

**a**

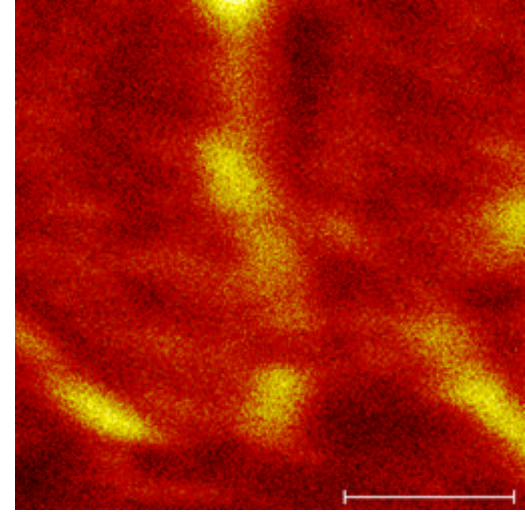

**b**

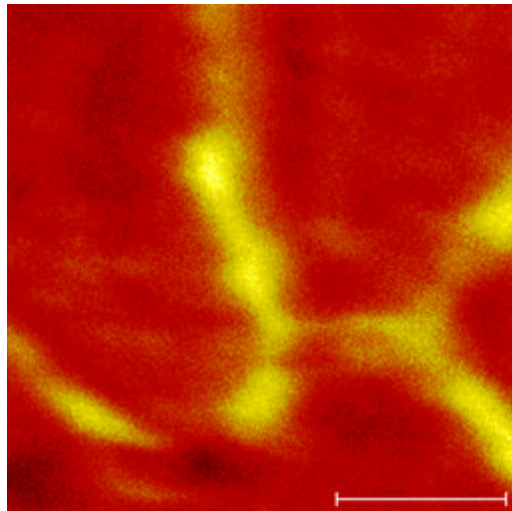

**c**

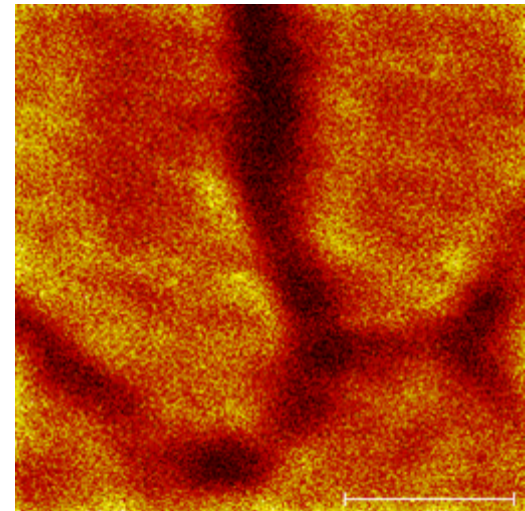

**d**

# The dislocations in Pd foils after annealing.

TEM

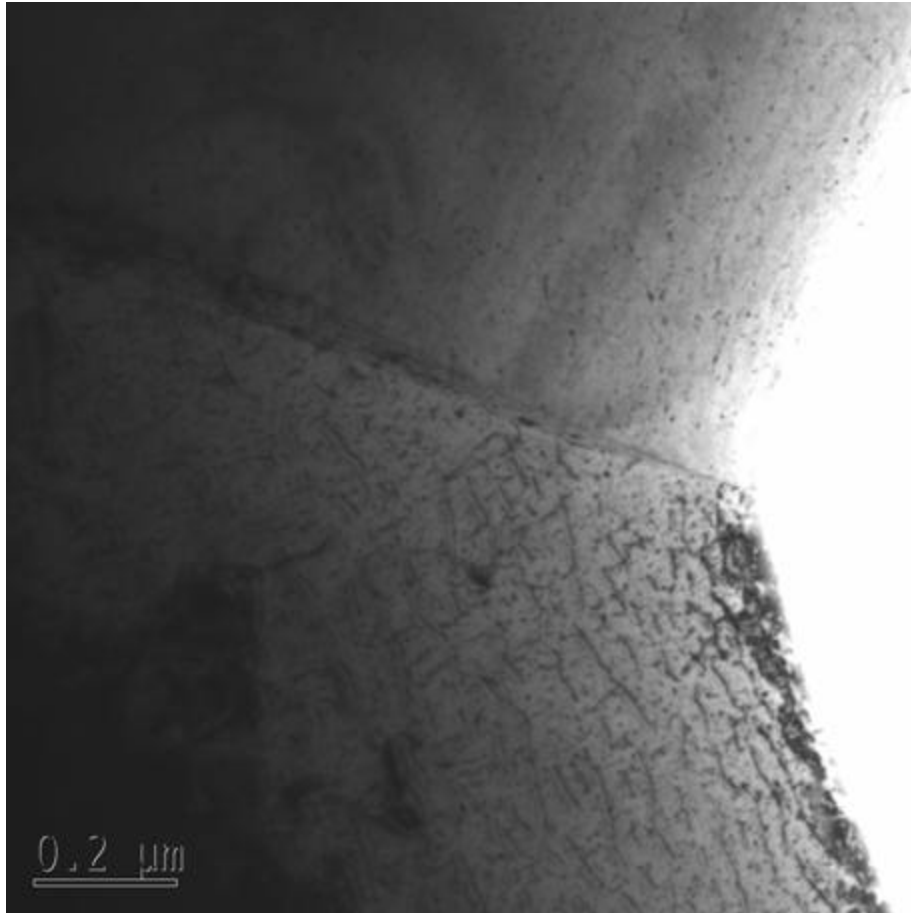

**#63**

**$3 \times 10^{10}, \text{cm}^{-2}$**

**Dislocation density**

**#64**

**$6 \times 10^{10}, \text{cm}^{-2}$**

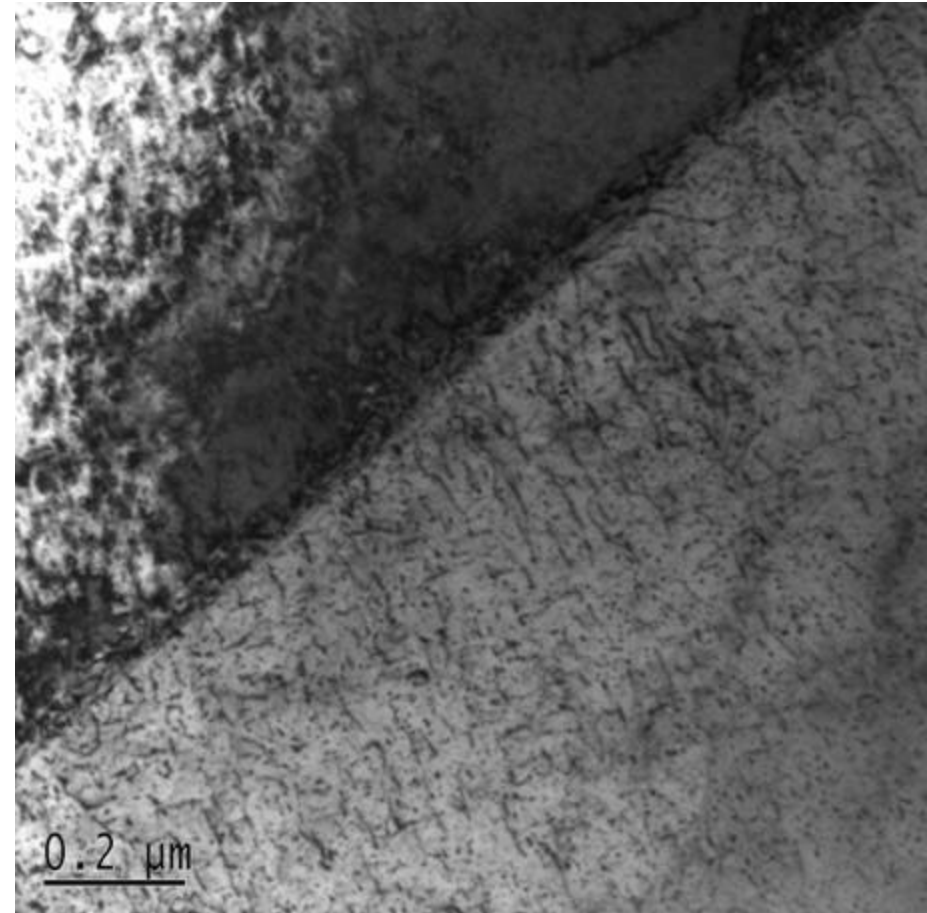

Plastic deformation of Pd foil caused by D<sub>2</sub> absorption.  
Planes of sliding (111) are visible.  
Sample #64

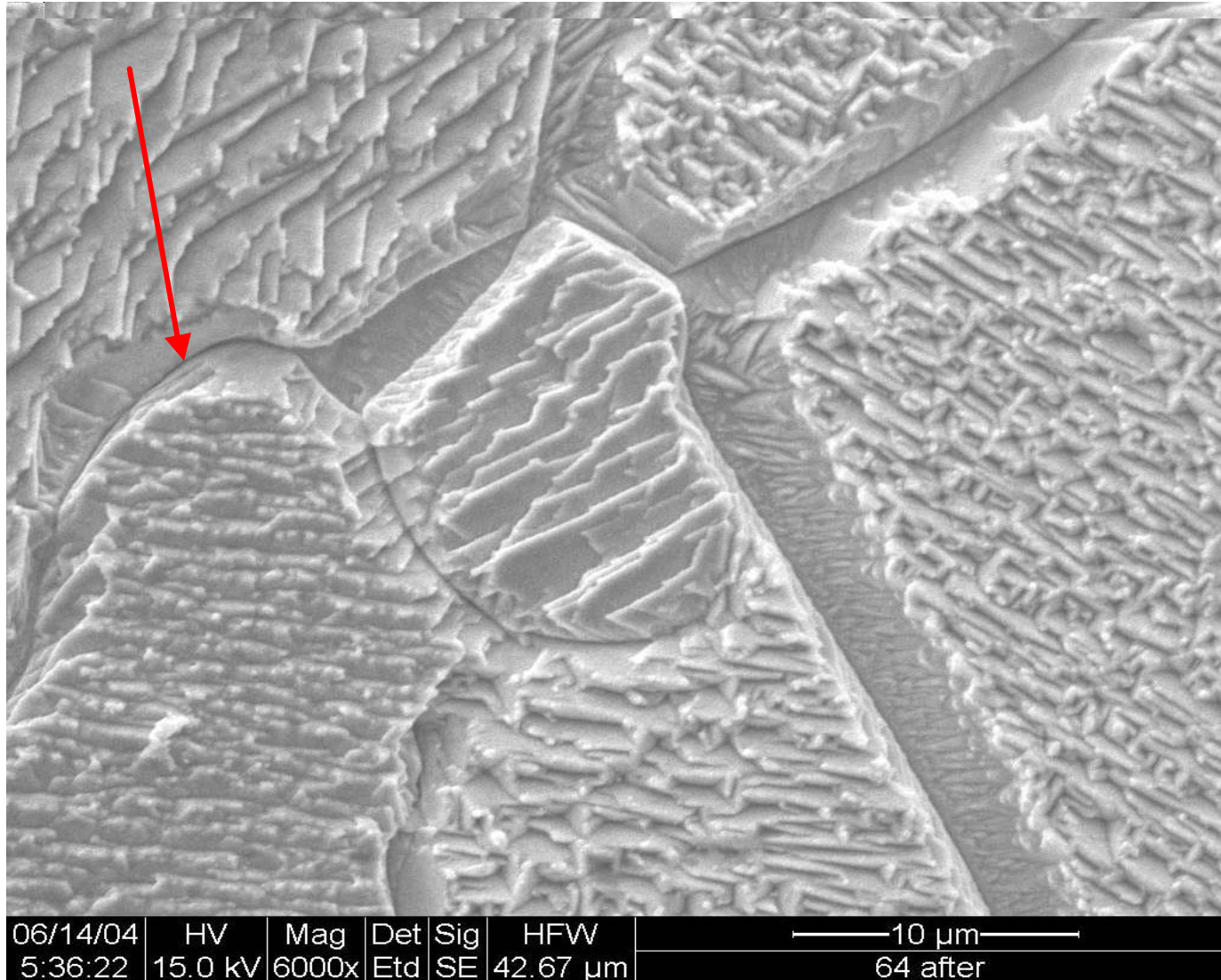



The area that is shown in the previous picture by an arrow.

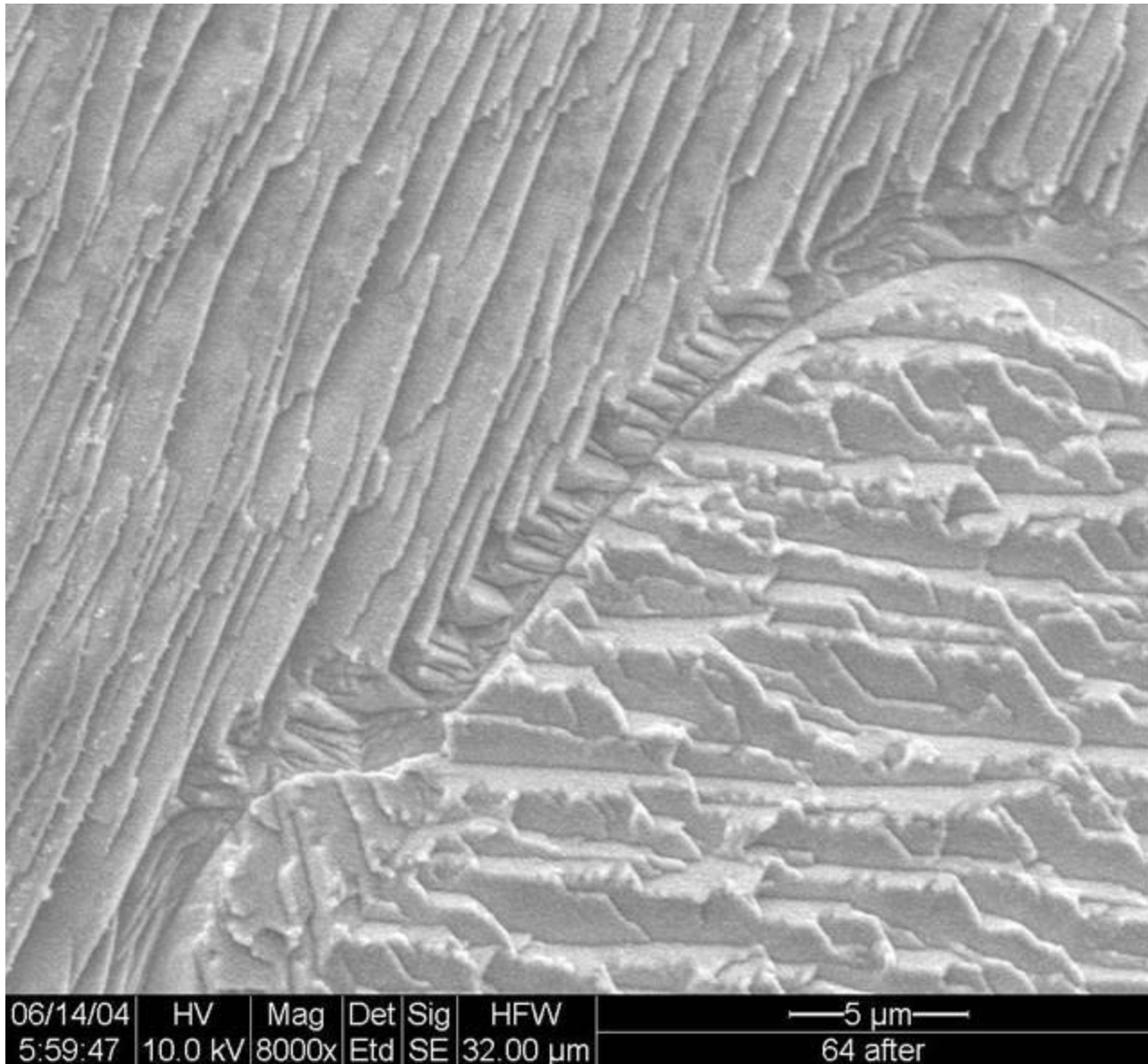

# Sample #56

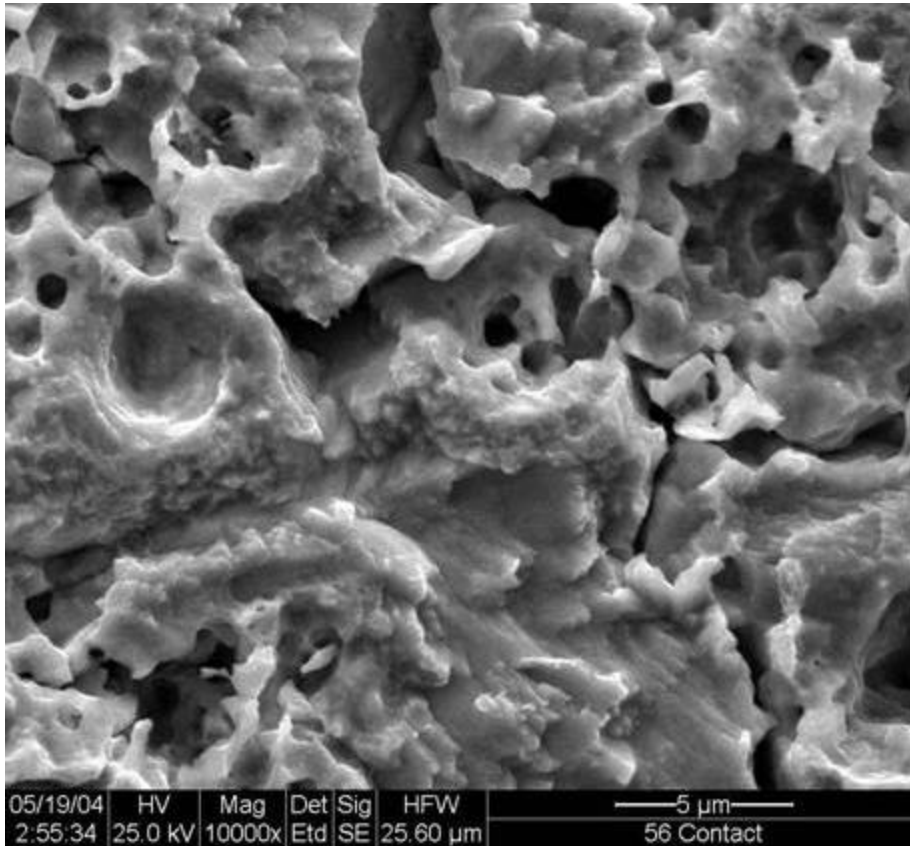

**Contact area**

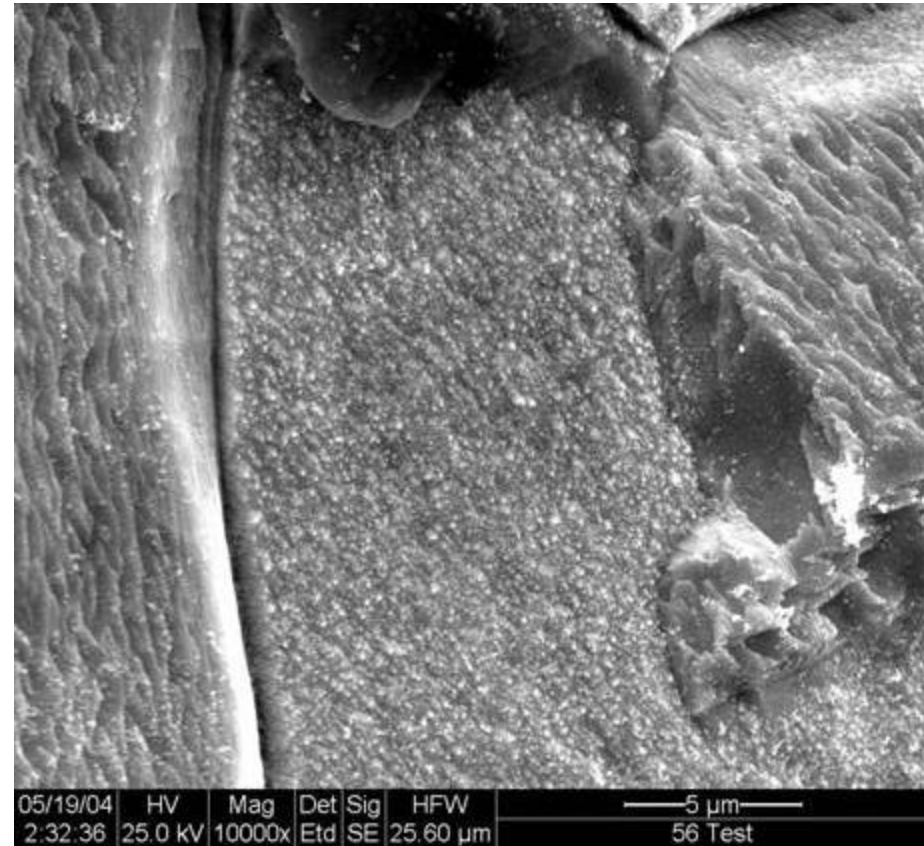

**Working area**

# Brittle destruction of Pt Wire Sample #64

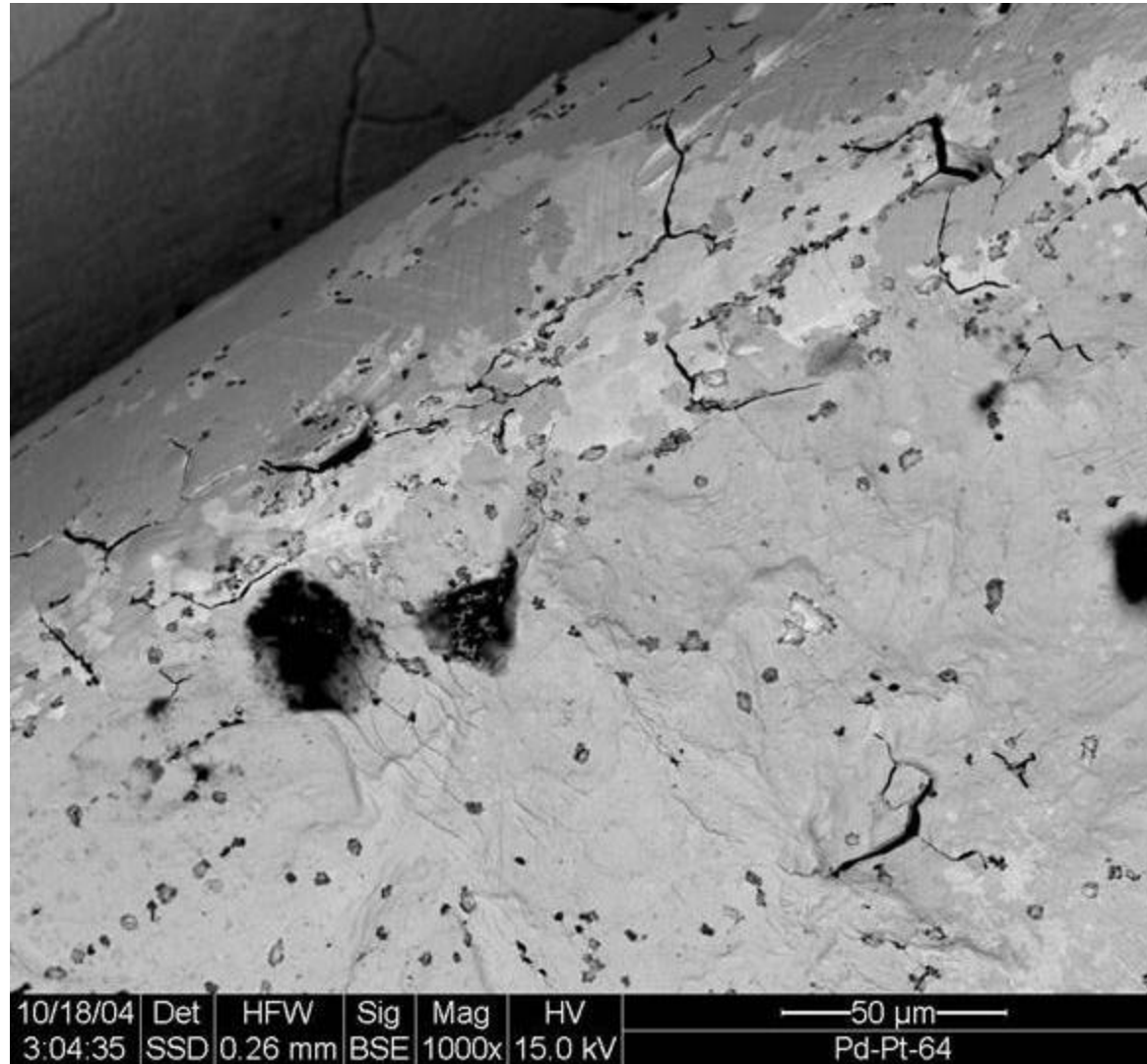

# Summary of Material Analysis

- Pd surface is covered at least with two types of impurities. The first one is a lubricant used at a rolling process with Pd during plastic deformation of the metal. The second one is a result of adsorption of air components by Pd surface.
- The lubricant stains are of various sizes and configurations and present on surface of all samples before and after the electrolysis.
- Annealing at 850<sup>0</sup> does not fully remove the lubricant's components from Pd surface.
- The density of dislocations and the average size of grains in sample # 64 are twice higher, than in the reference sample.
- Nuclear reaction product can not be detected on surface zone due to high concentration of impurities. No He measurement has been attempted.

# SUMMARY

- Significant amount of excess heat has been generated in 3 experiments using 2 Pd foils.
- Dardik's modified SuperWaves have been used for current drive in all the three experiments.
- The average current density was relatively low: < **10 mA/cm<sup>2</sup>**
- The maximum excess power was **2500%**. This range of excess power is suitable for commercial applications (although the operating temperatures were too low for such applications).
- The maximum excess energy generated with a single Pd foil is **5.7 MJ**.
- This corresponds to a specific energy of **24.8 KeV per Pd atom**.
- The highest average power density obtained is **~70 W/g Pd** (versus 20 to 50 W/g U in commercial fission reactors).

## SUMMARY (cont.)

- Significant increase in the tritium concentration in the electrolyte has been observed. However, the amount of tritium produced is negligible as compared with the excess energy generated.
- No measurement of He has been attempted.
- The Pd cathode surface was contaminated by what appears to be lubricant from the roller used for pre-treatment as well as impurities adsorbed from the air.