

Review of Recent Work at ENEA

M. Apicella*, E. Castagna*, L. Capobianco*, L. D'Aulerio*, G. Mazzitelli*, M. McKubre***, F. Sarto*, C. Sibilia**, A. Rosada*, E. Santoro*, F. Tanzella***, V. Violante*

(*) ENEA Frascati Research Center, V. le E. Fermi 45 00044 Frascati (Roma) Italy

(**) La Sapienza University, Via Scarpa, 14 00100 (Roma) Italy

(***) SRI International 333 Ravenswood Ave, Menlo Park CA 94025 USA

Topics

1) Material Science & Reproducibility

2) Calorimetry

3) Laser Triggering of Excess of Power

4) ^4He Measurements

Excess of Power is a Threshold Effect

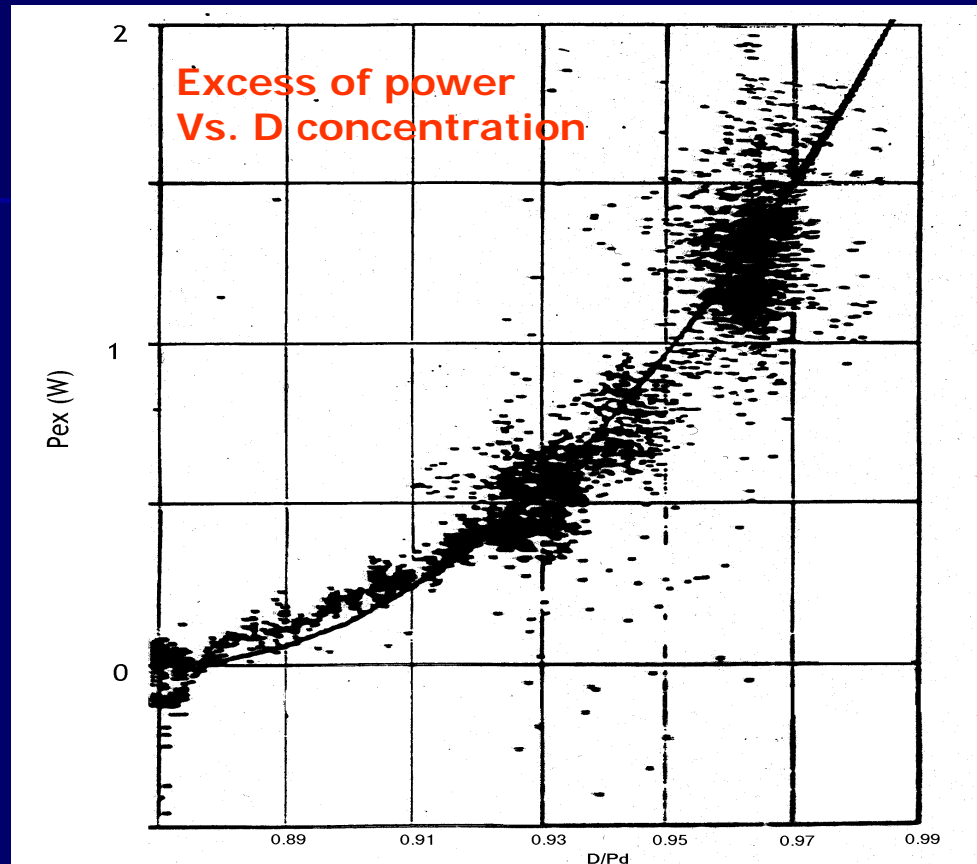

Excess of power vs. D concentration: milestone in the history of CMNS.
1992: McKubre (SRI, USA), Kunimatzu (IMRA, Japan).

Excess of power reproducibility requires reproducibility of high loading of deuterium.

High Loading Reproducibility and then Excess of Power Production within Deuterated Metals are Controlled by Equilibrium and not Equilibrium Phenomena

$$\mu_H = \frac{1}{2} \mu_{H_2}$$

Equilibrium condition

Chemical potential of hydrogen in the metal lattice is strongly affected by the force fields that modify the free energy of the system like stress:

$$\mu_H^* = \mu_H - \bar{V} \text{tr} \bar{\sigma}_h$$

Absorption of hydrogen isotopes inside a metal lattice is also a **not - equilibrium** problem because of the diffusive process produced by a chemical potential gradient. In presence of stress mass transfer is described by:

$$\frac{\partial \bar{c}}{\partial \tau} = \frac{\partial^2 \bar{c}}{\partial \bar{x}^2} - (1 - \eta) b \frac{\bar{V} E}{RT} \left(\frac{\partial \bar{c}}{\partial \bar{x}} \right)^2 - (1 - \eta) b \frac{\bar{V} E}{RT} \bar{c} \frac{\partial^2 \bar{c}}{\partial \bar{x}^2} - b \frac{\bar{V} E}{RT} \frac{\partial \eta}{\partial \bar{x}} \bar{c} \left(\frac{\partial \bar{c}}{\partial \bar{x}} \right)$$

(η =% of relaxed stress)

Calculations Results

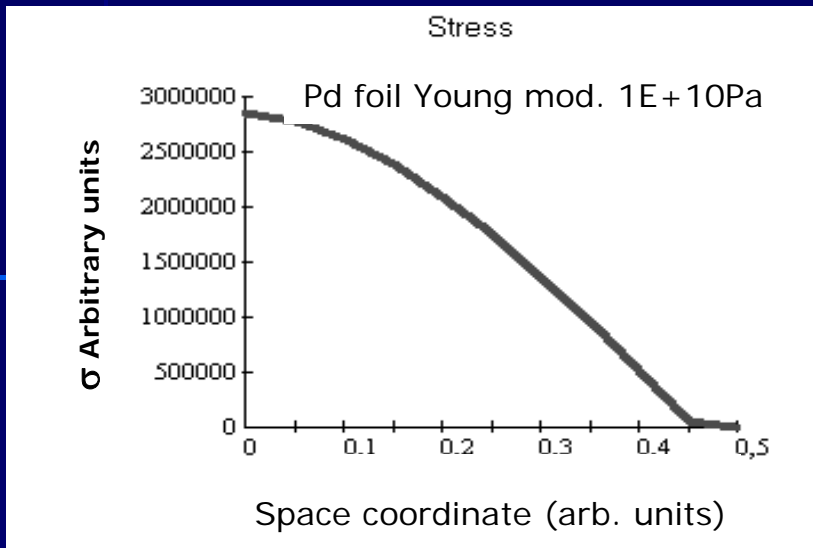

Equilibrium stress profile for high H solubility in Pd.

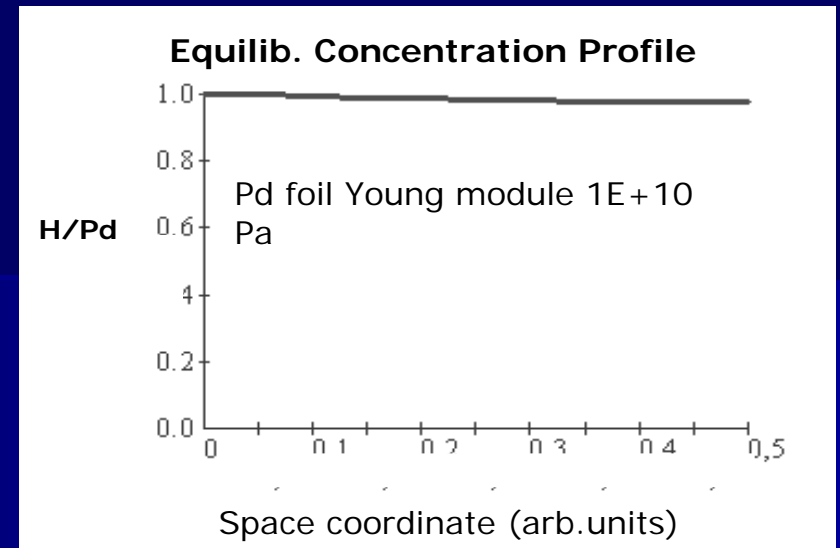

Equilibrium conc. profile for high H solubility in Pd.

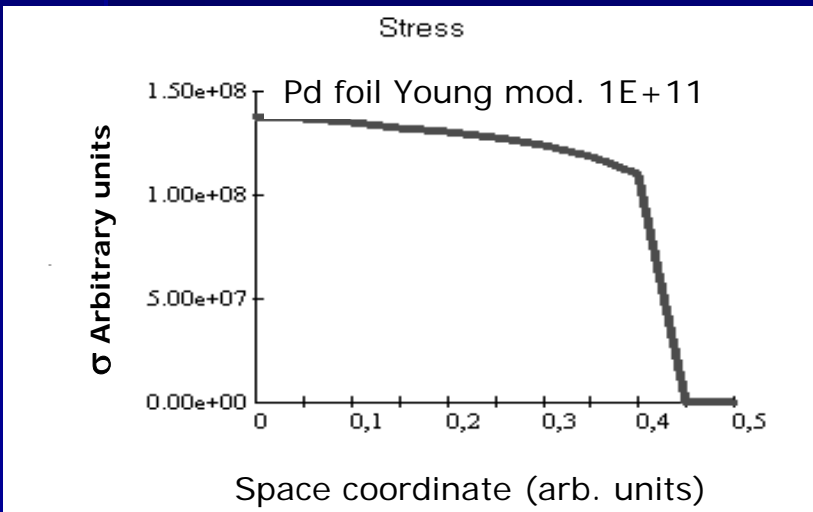

Equilibrium stress profile for low H solubility in Pd.

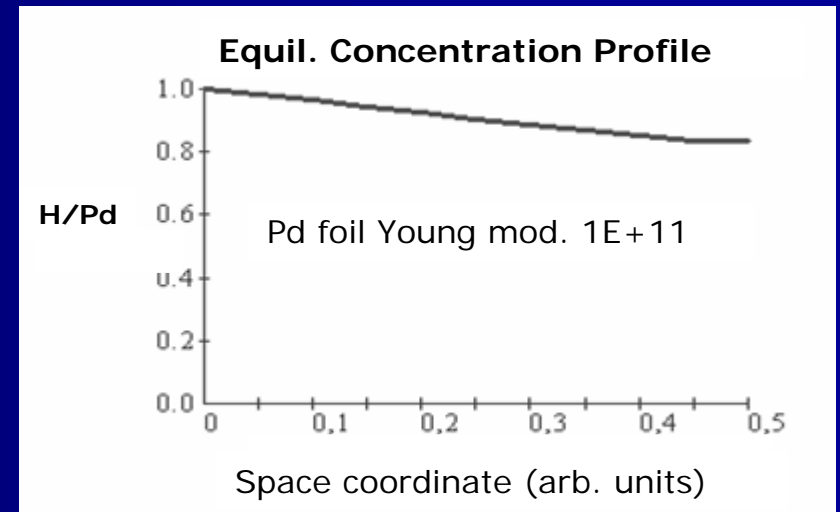

Equilibrium conc. profile for low H solubility in Pd.

Metallurgy and Loading

Theory showed that self induced stress, created by concentration gradients, reduce hydrogen solubility in metals.

Metallurgical treatments have been studied to reduce the above mentioned effects.

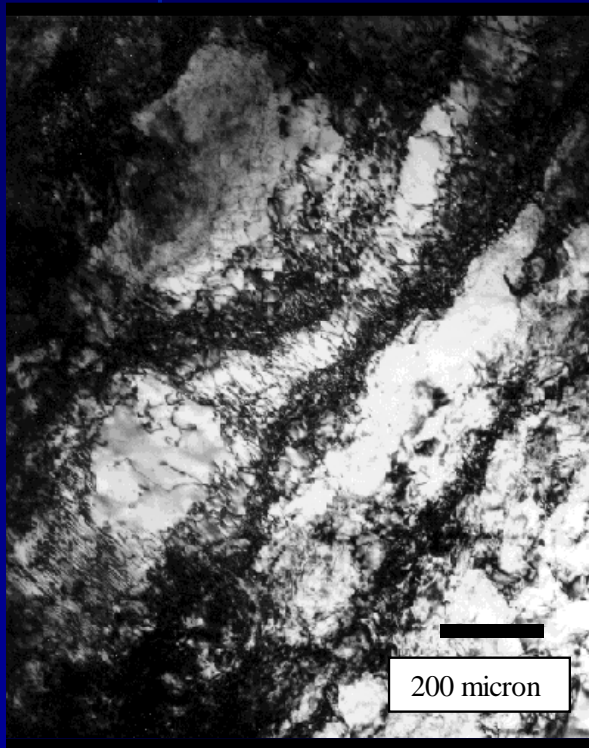

Cold worked Pd foil.

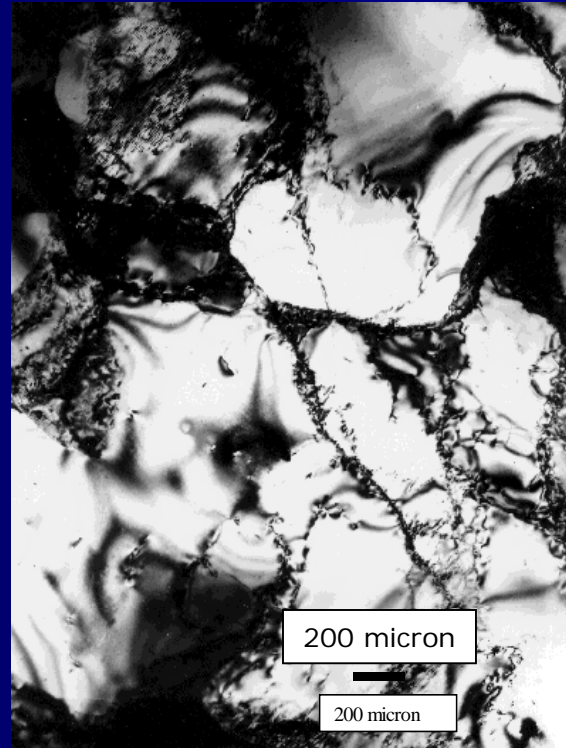

Cold worked and annealed at 1100 °C for 5 hr Pd foil.

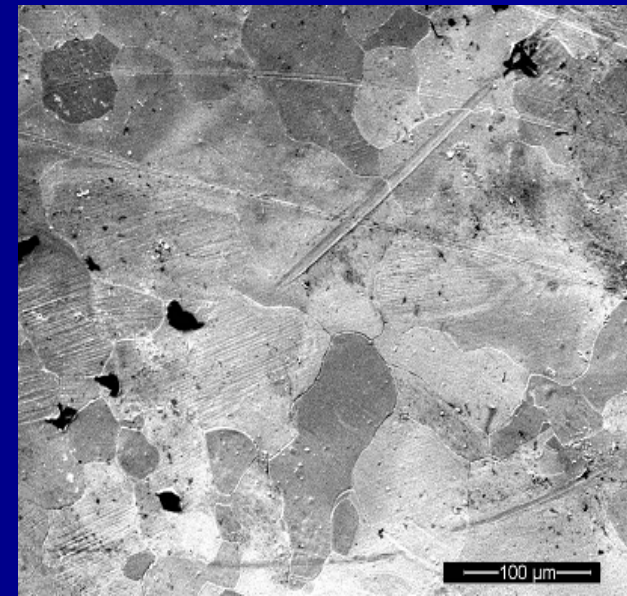

Cold worked and annealed at 850 °C for 1 hr.

D/H Concentration Measurement as Resistance Measurement

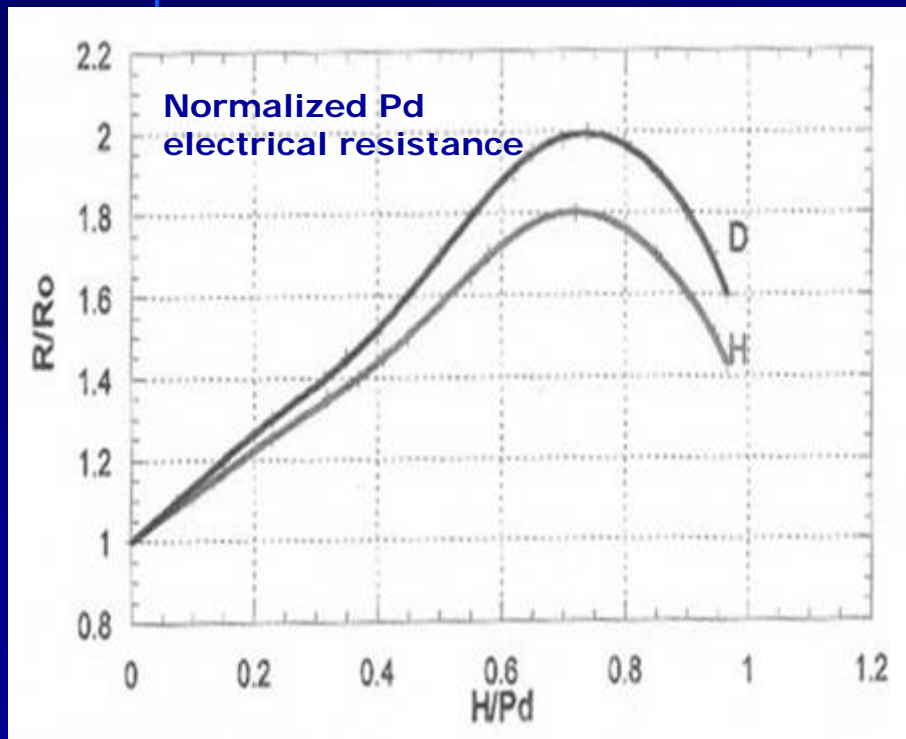

Baranowsky curves.

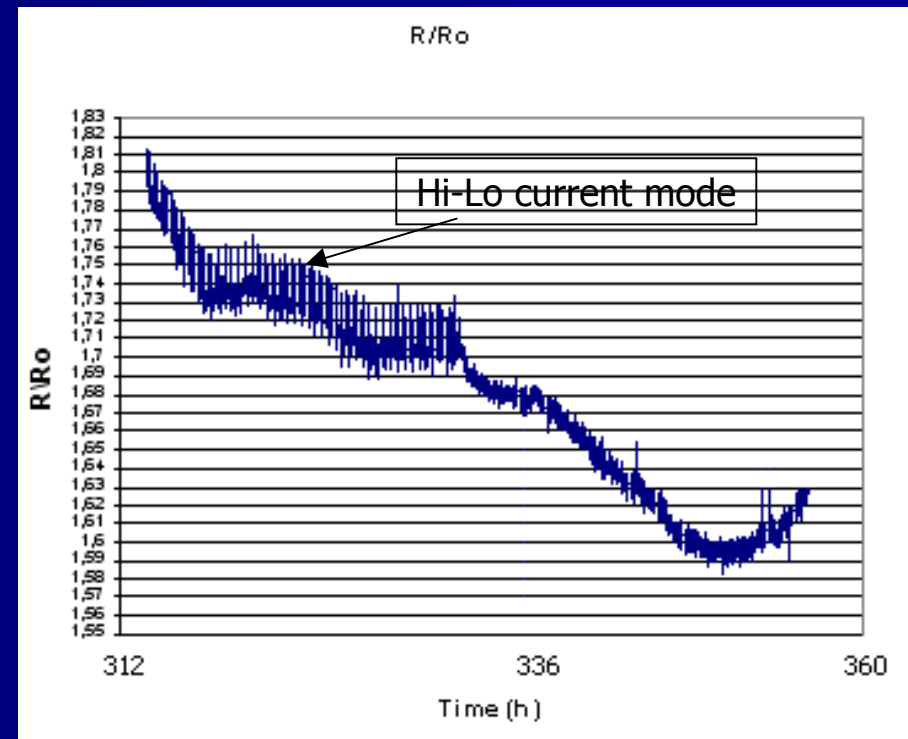

Loading evolution into a treated Pd sample.

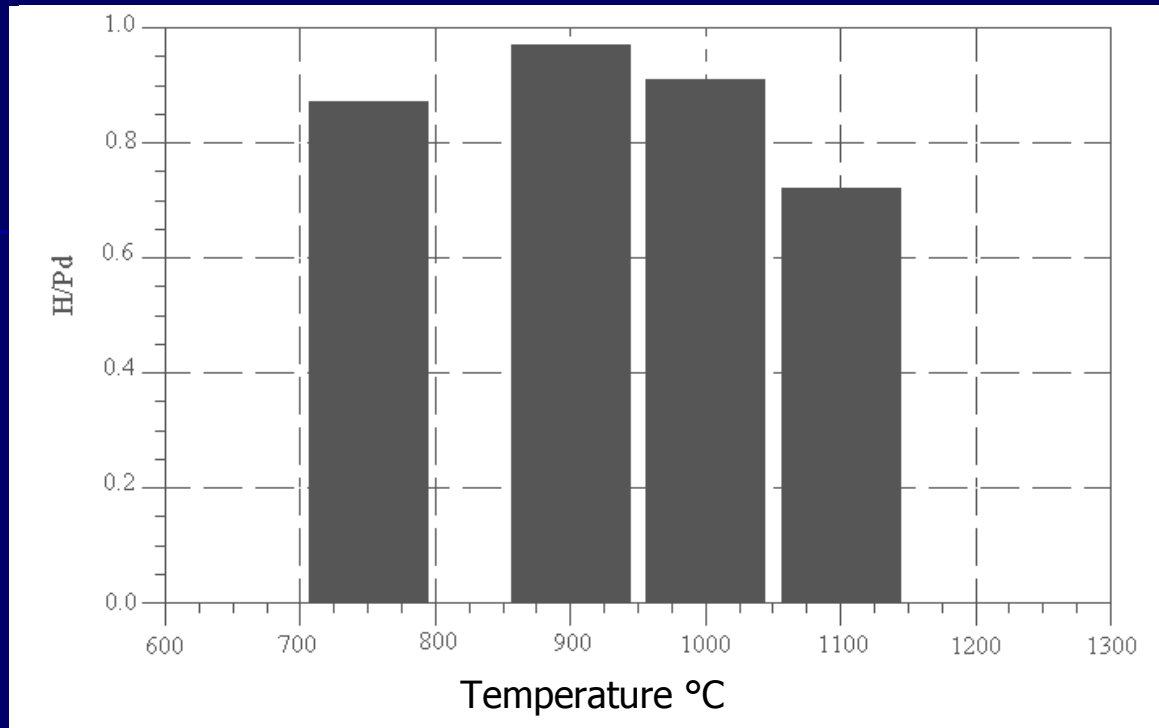

Annealing temperature effect on H loading in Pd.

Self induced stress, created by very steep concentration gradients, makes impossible to achieve the concentration threshold $D/Pd > 0.95$ giving excess of power production.

A Proper microstructure of Pd due to metallurgical treatment allows high D loading.

References

- A. De Ninno, V. Violante et Al., Consequences of Lattice Expansive Strain Gradients on Hydrogen Loading in Palladium. Phys. Rev. B, Vol. 56, N. 5 (1997) 2417-2420.
- A. Adrover, V. Violante et Al. Stress induced diffusion of hydrogen in metallic membranes, Cylindrical vs. planar formulations I, J. Of Alloys and Compounds I(2003).
- A. Adrover, V. Violante et Al. Stress induced diffusion of hydrogen in metallic membranes, Cylindrical vs. planar formulations II, J. Of Alloys and Compounds I(2003).
- A. Adrover V. Violante et Al. Effects of self-stress on hydrogen diffusion in Pd membranes in the coexistence of α and β phases. J. of Alloys and Compounds II (2003).

Flow Calorimetry on Closed Cells with Recombiner

$$P_{In} = V I$$

$$P_{Out} = W c_p (T_{Out} - T_{In})$$

W = coolant mass flow rate

ENEA Flow Calorimeter

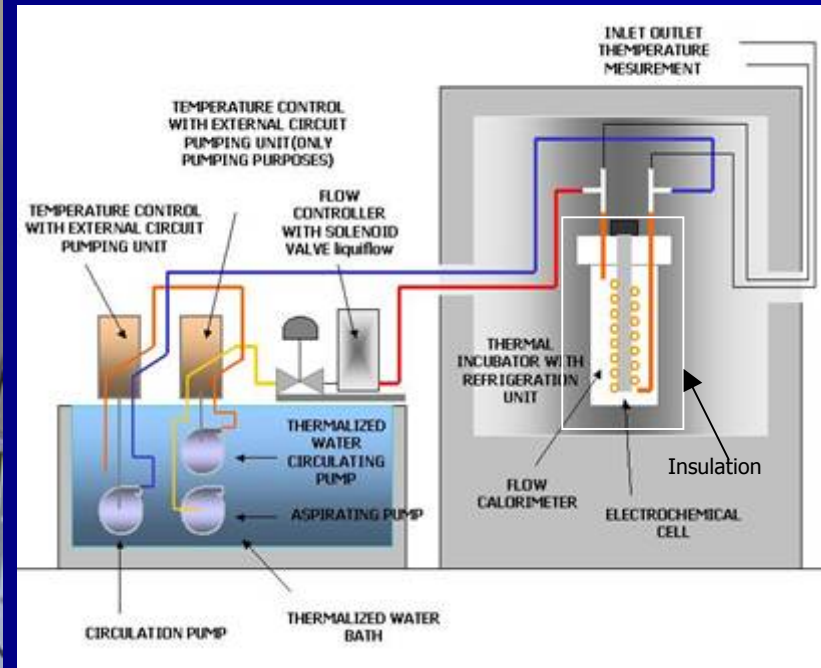

Memmert Calorimetric box ($\pm 0.05^\circ\text{C}$) + Haake thermostatic bath + Bronkhorst high precision mass flow meter + HP-4263 LCR Meter. Measure limit: $50 \pm 15 \text{ mW}$

Flow Calorimeter FEM Analysis

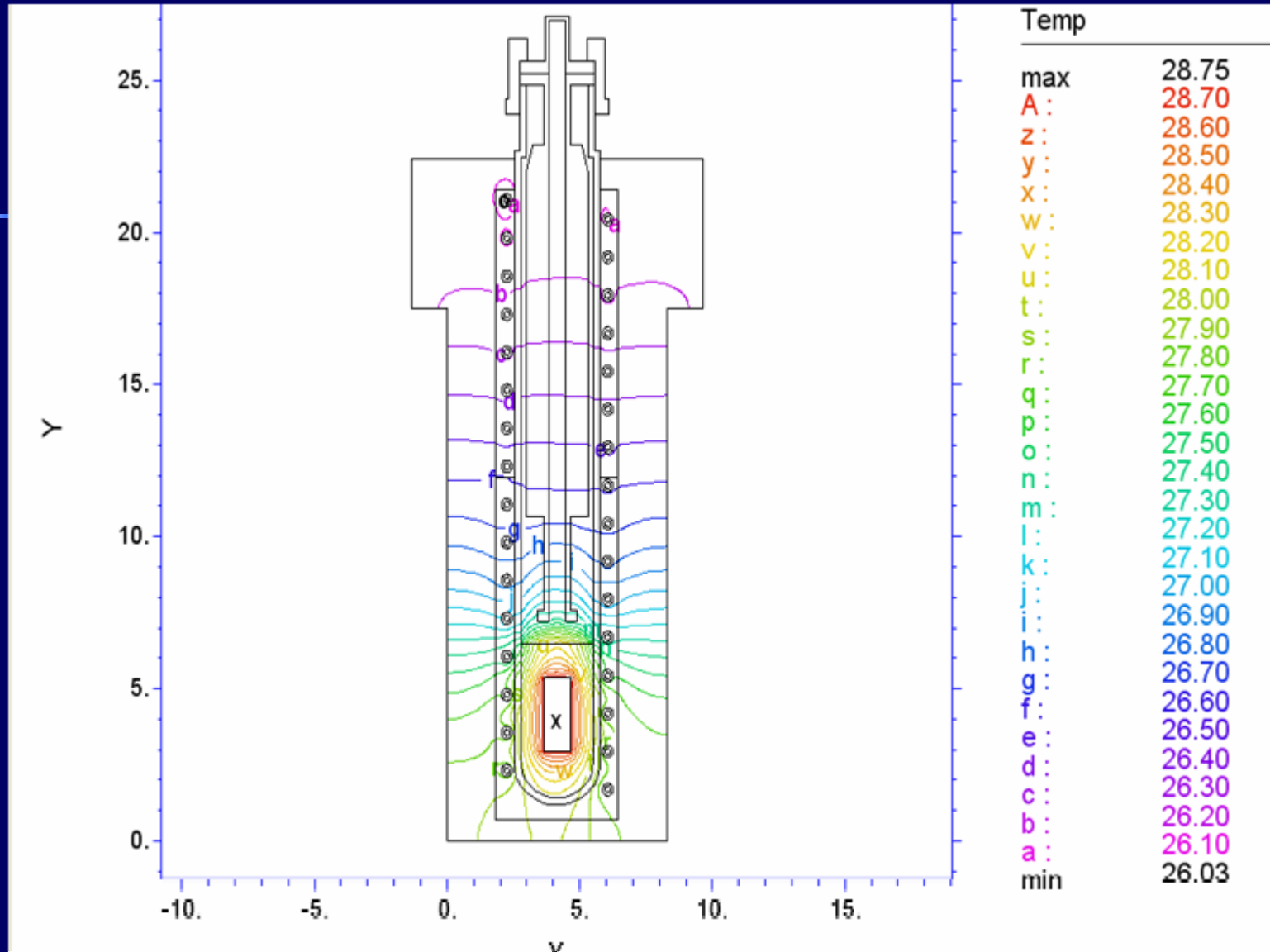

Finite element modelling has applied to design the calorimetric system

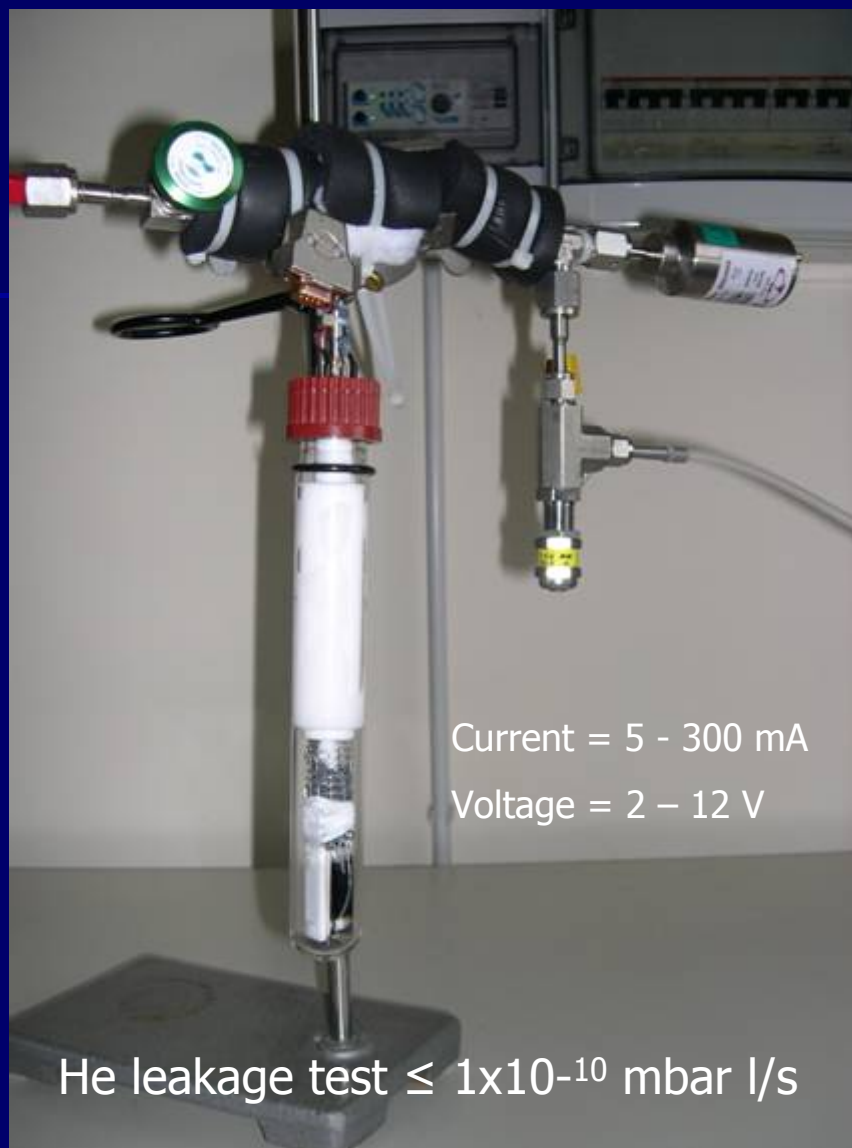

Symmetric electrochemical cell :Pt-foil/Pd-foil/Pt-foil
(20x10mmx50 μ m Pd).

Reference Experiments with Hydrogen at ENEA

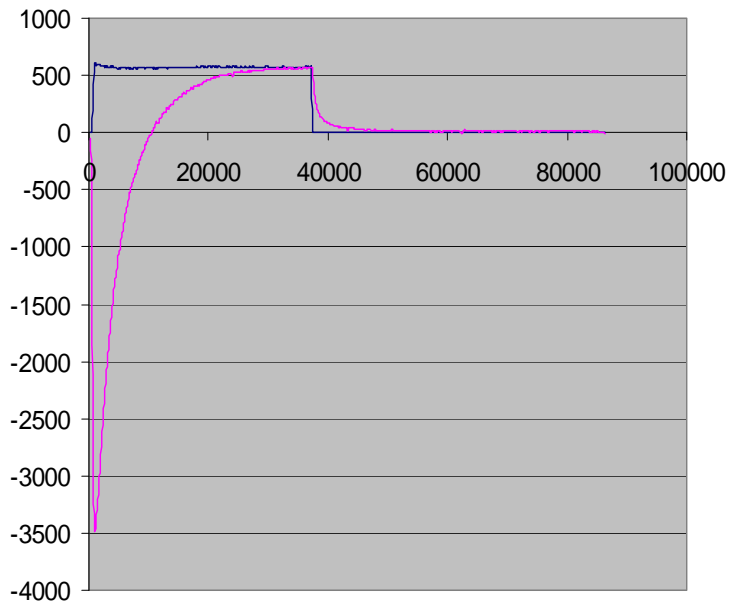

— Pin (mW)
— Pout (mW)

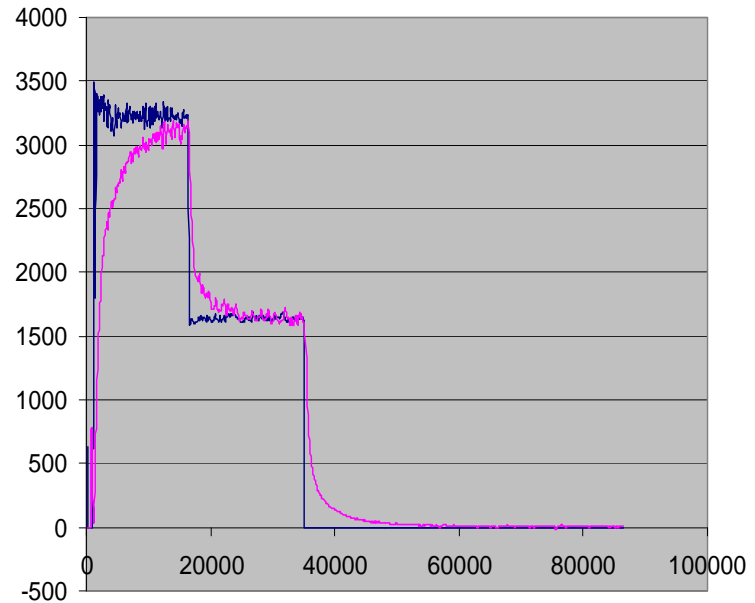

— Pin (mW)
— Pout (mW)

Input and output of power during electrochemical loading of hydrogen into Pd foils. Calorimeter efficiency = 97.5%.

Energy & power (input and output) during calibration with H₂O 0.1 M LiOH

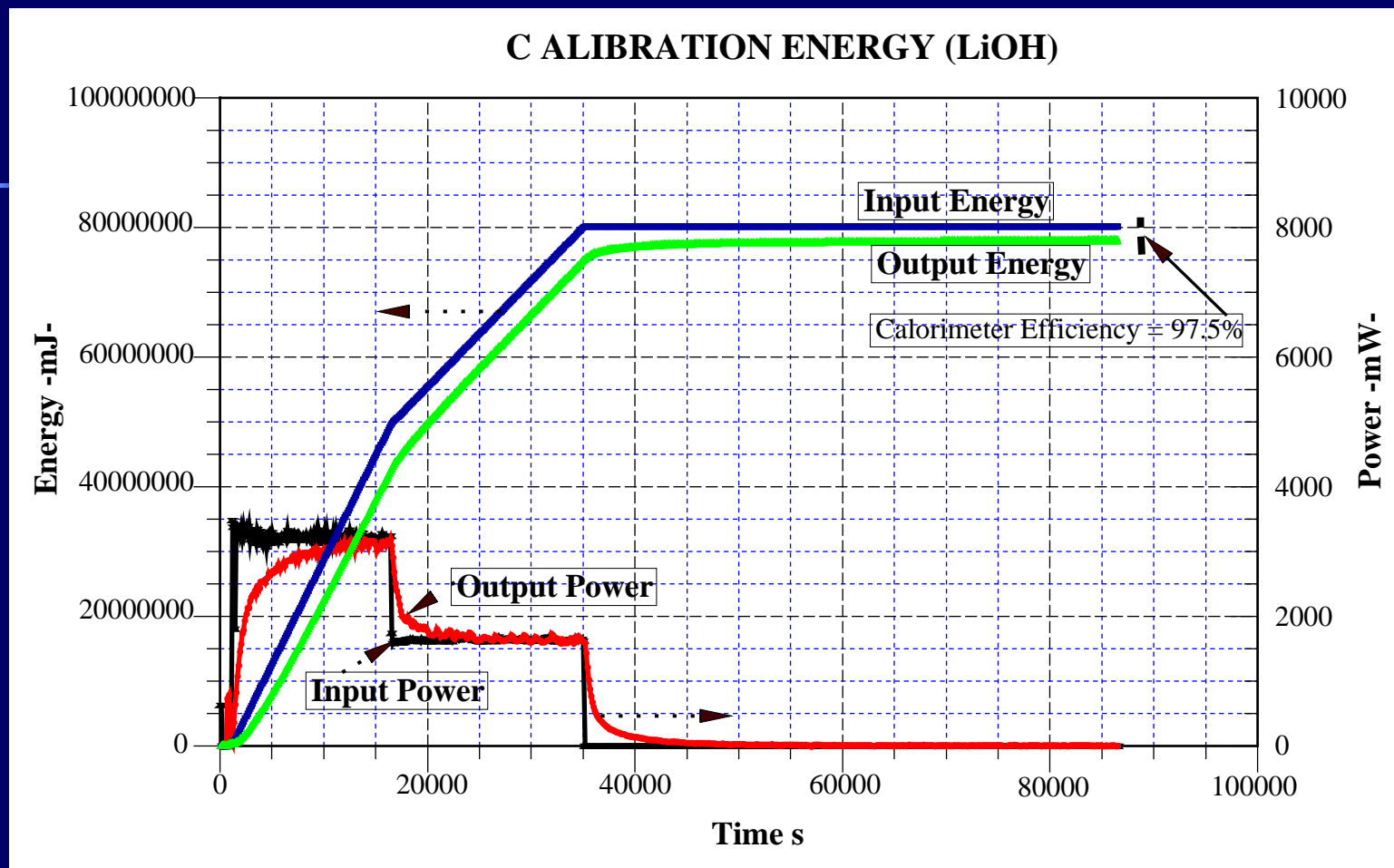

Plot of energy & power (input and output) for calibration with H₂O 0.1 M LiOH.

Flow Calorimeter Calibration Curve

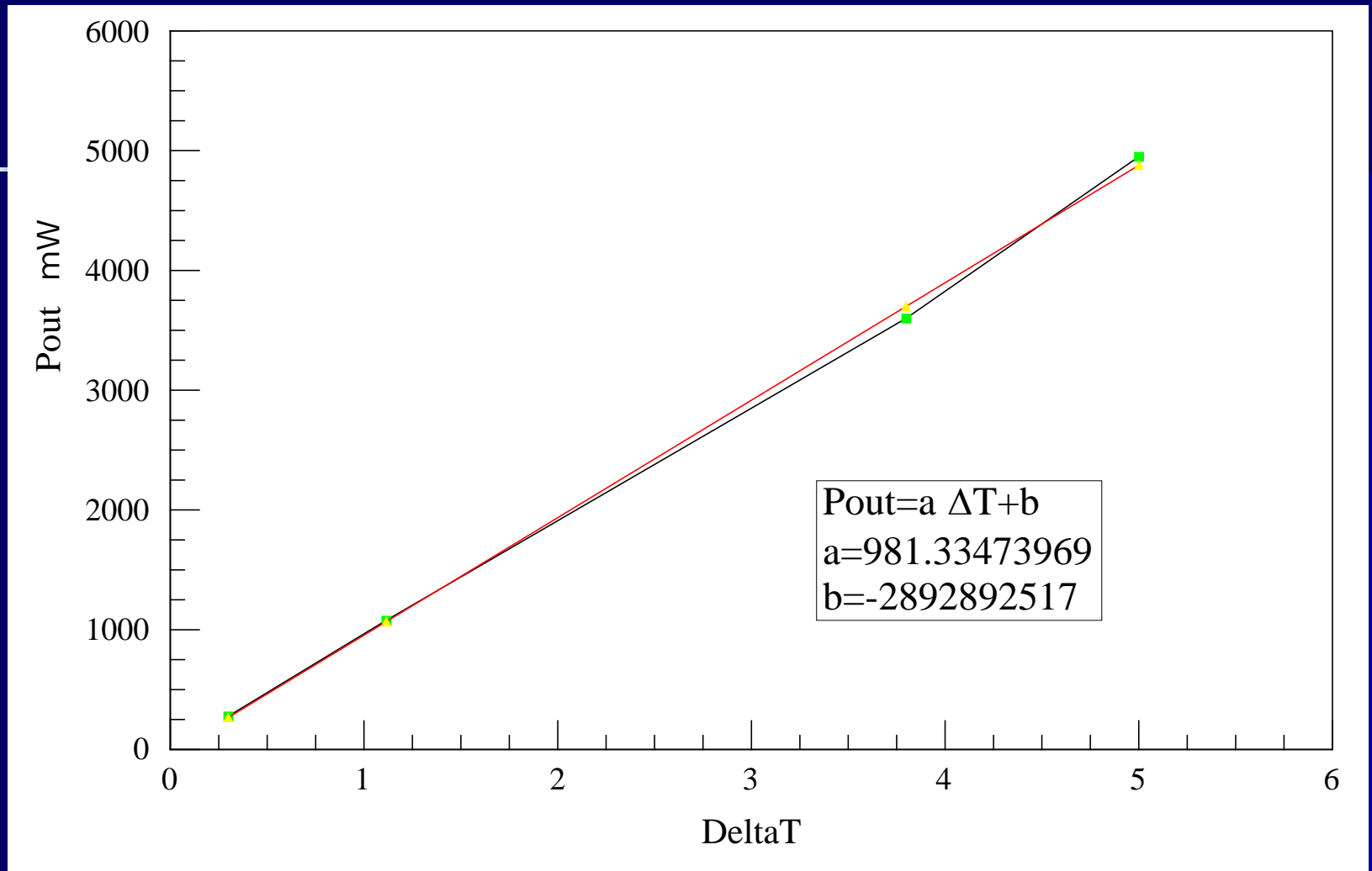

In principle flow calorimetry doesn't require calibration

Excess of Power

C1 and C3 Experiments

Excess of Power Experiment C1

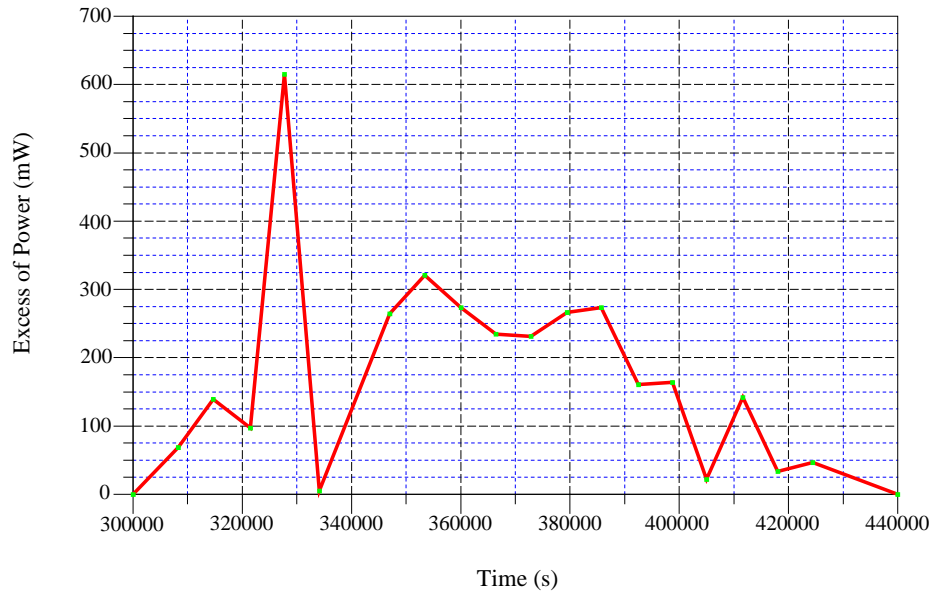

Experiment C1: excess of power vs time (45 KJ of produced energy = 35 MJ/mol Pd)

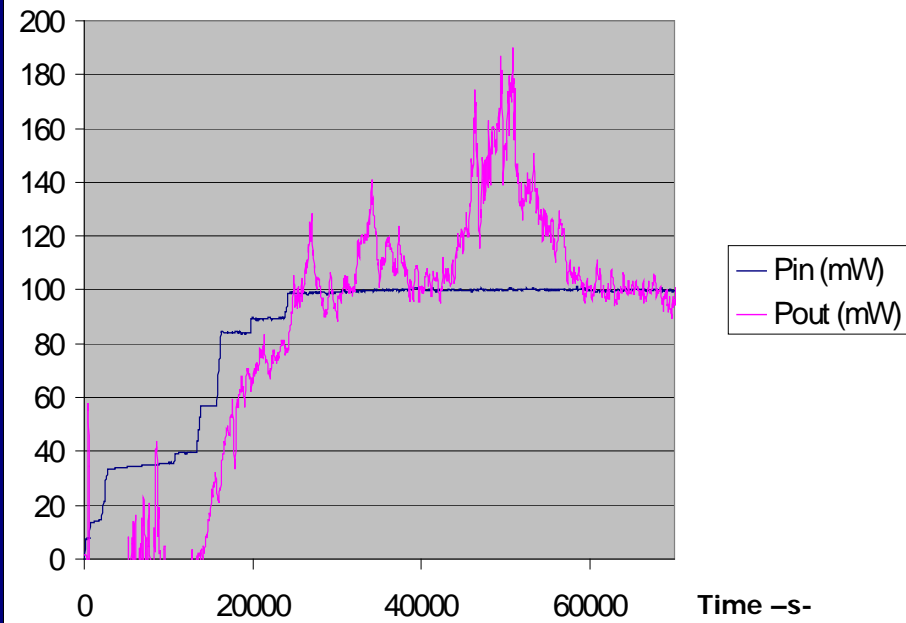

Experiment C3: excess of power vs time

Excess of Power and Excess of Energy in C3 Experiment

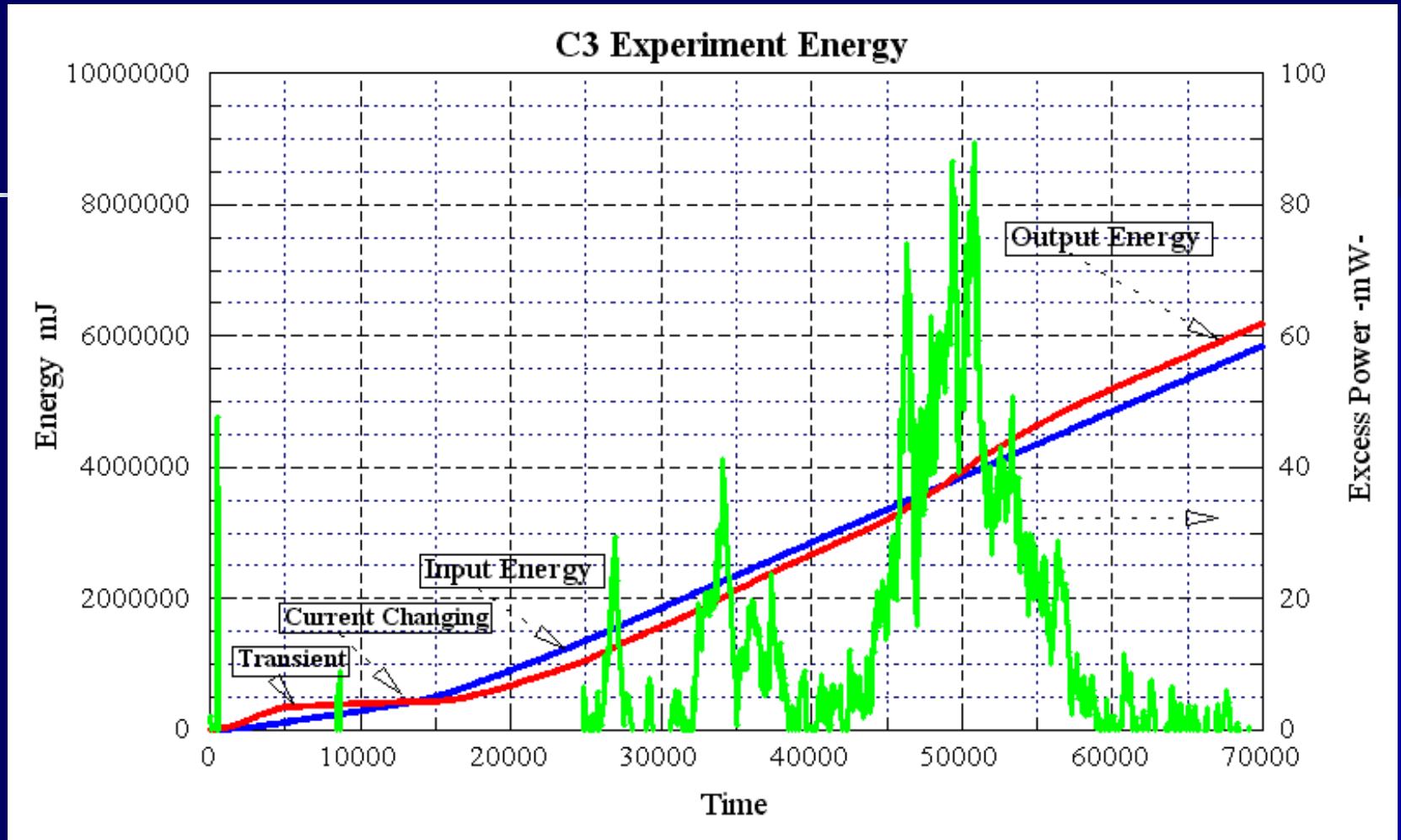

C3 experiment: plot of energy & power (input and output)

Excess of Power at SRI

Excess of Power mW

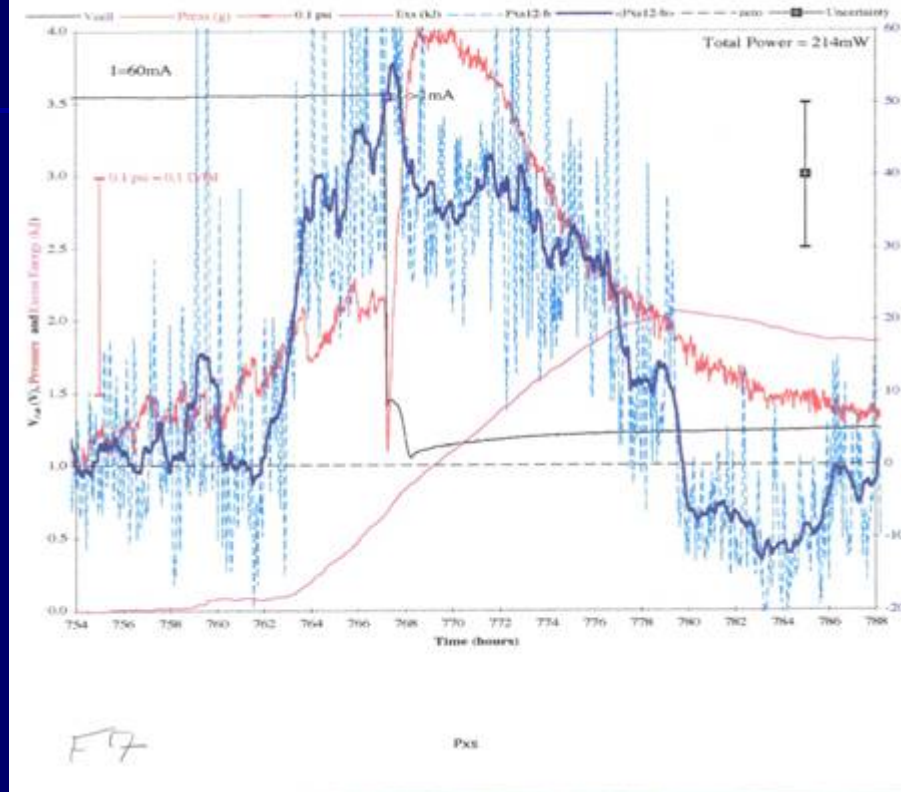

SRI results by using a treated Pd foil.

Similar and enhanced results have been obtained by Dr. T. Zilov (Energetics Technology) by using the same materials.

Remarks

Why a trigger ?

Two excesses of power have been observed over 9 experiments although the achieved D concentration in Pd (atomic fraction) has always been larger than 0.9.

The loading threshold $D/Pd > 0.9$ is clearly only a *necessary condition*.

Plasmons-Polaritons Laser Triggering

According to the idea that collective electron oscillations have a key role in LENR processes a proper trigger has been introduced to create surface plasmons (polaritons).

Surface plasmons are quantum of plasma oscillations created by the collective oscillation of electrons on a solid surface.

Surface plasmons may be generated by mechanisms able to produce charge separation between Fermi level electrons and a background of positive charges (i.e. lattice atoms):

- 1) Electrons beam.
- 2) Laser stimulation.
- 3) Lattice vibrations.
- 4) Charged particles interacting with a surface.

Coupling by Roughness

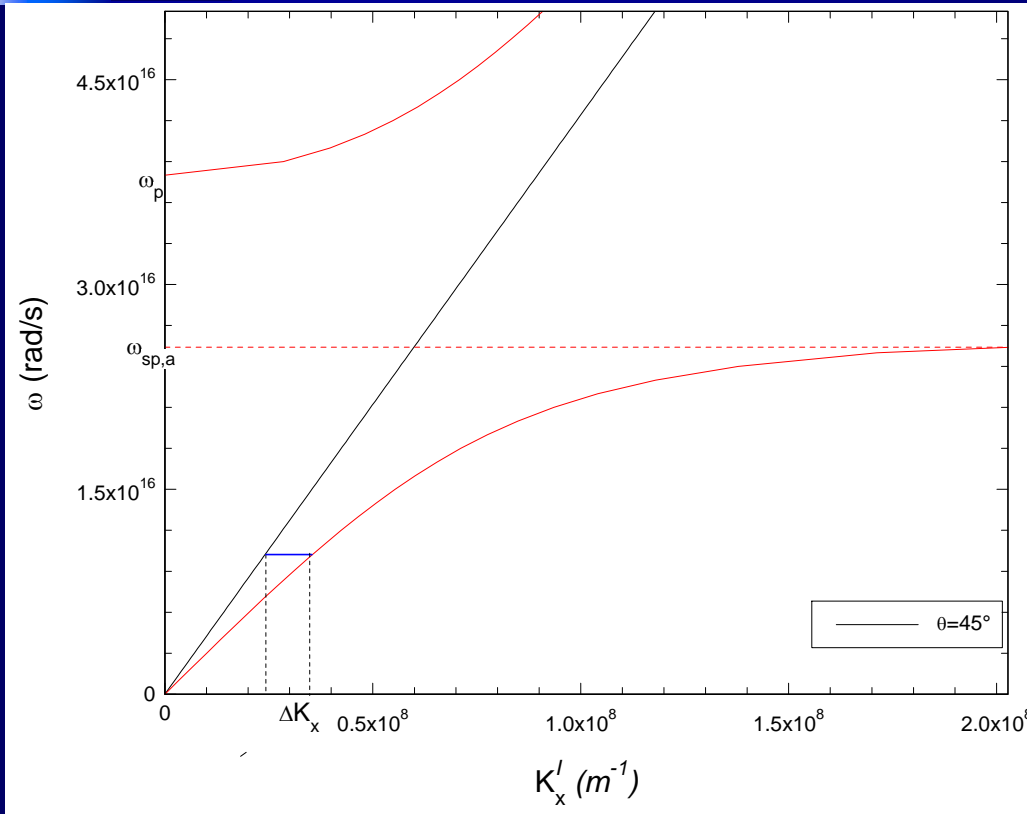

$$K_x = \frac{\omega}{c} \sin \theta \pm \Delta K_x = K_{sp}$$

Where:

$$\Delta K_x = \pm n g$$

$$g = \frac{2\pi}{a}$$

$n=1,2,\dots$

a is the surface corrugation lattice parameter.

Shift of the incident radiation wave vector produces plasmons excitation: a proper corrugation of the surface creates the required shift.

Isoperibolic Calorimetry under Laser Triggering

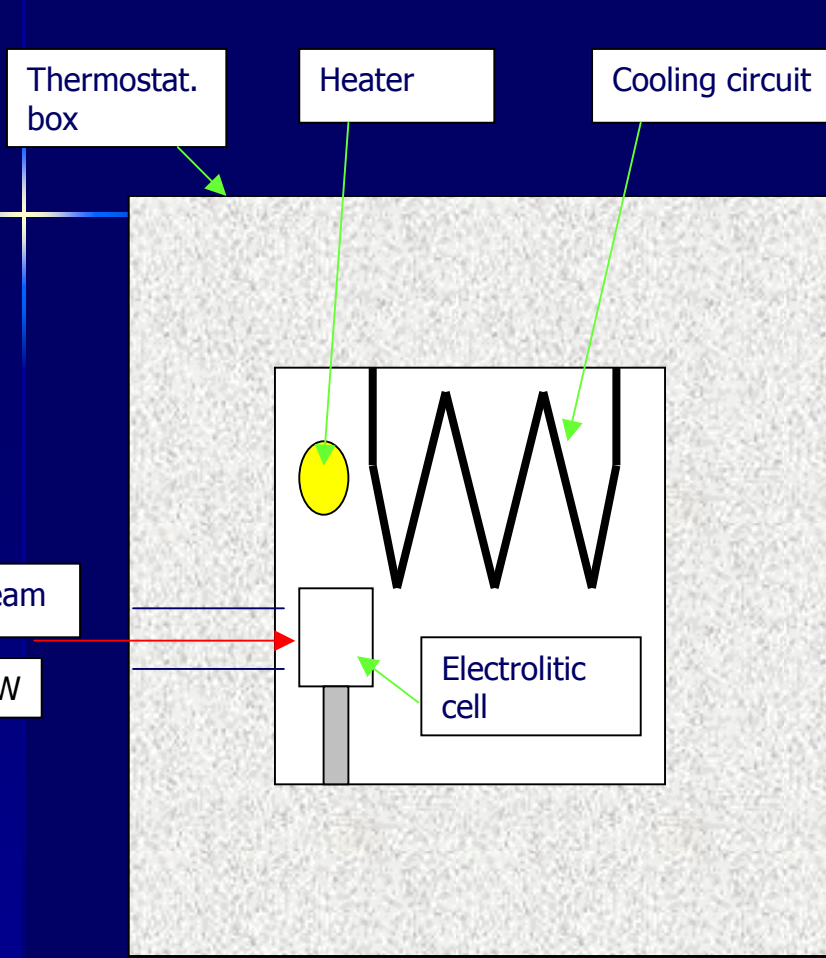

Calorimetric system for laser triggering experiments (T Box = Set p. ± 0.15 °C)

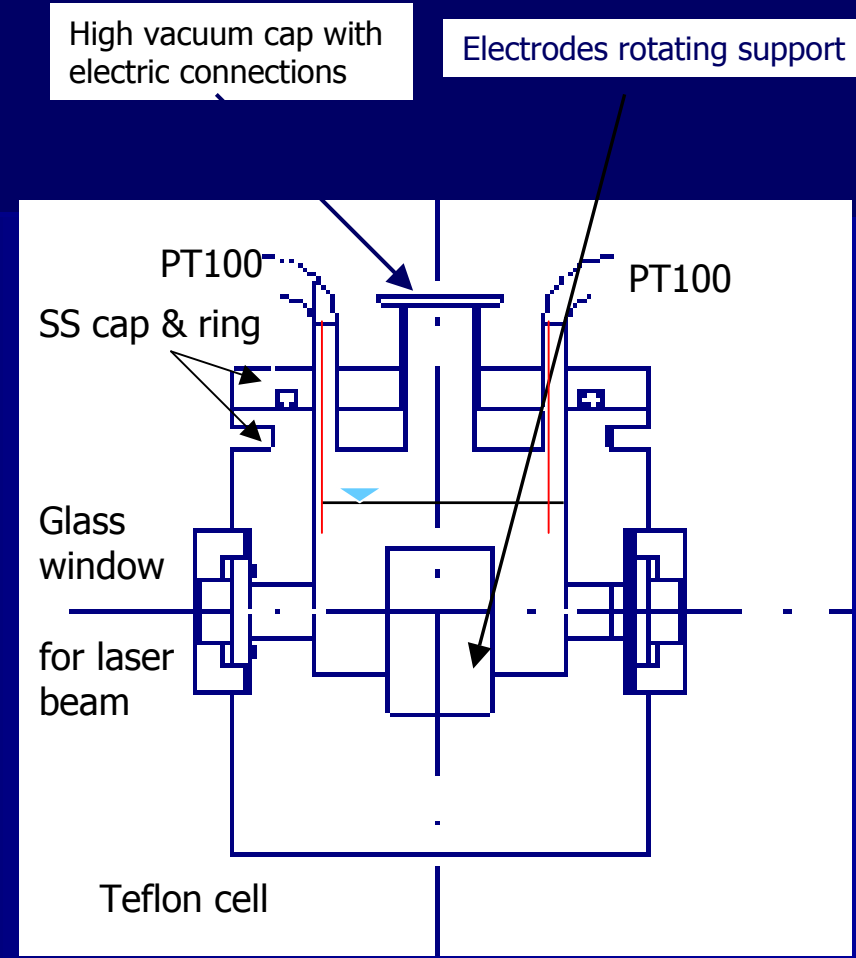

Electrochemical cell for laser triggering Experiments. He leakage $\leq 10^{-10}$ mbar l/s.

Pd foil (20x10 mm x 50 μ m) cathode, spiral Pt wire anode.

Current = 5 - 400 mA
Voltage = 2 - 15 V

Electrochemical Cell FEM Analysis to Design the Calorimetric System

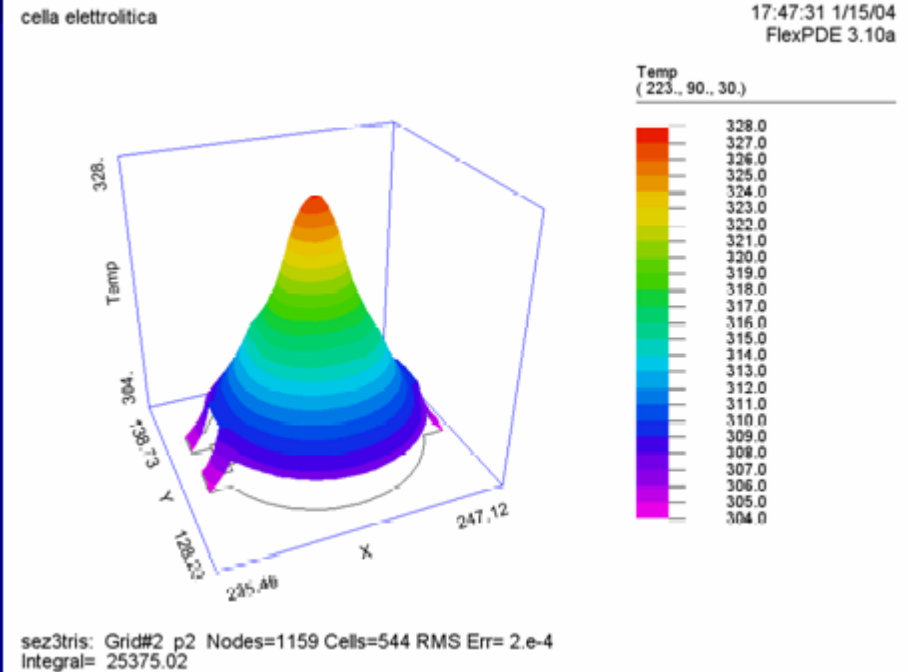
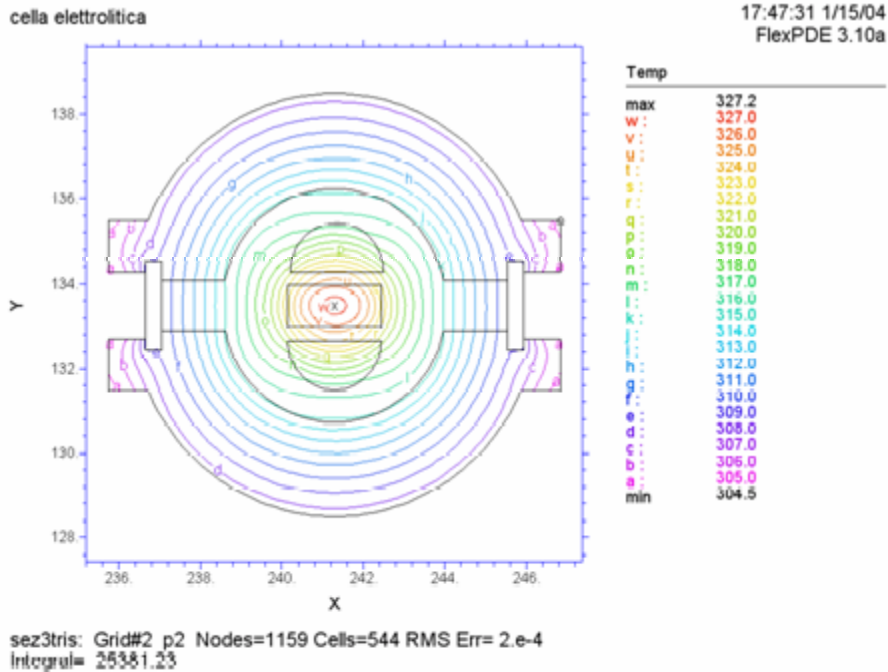

Calculated temperature profiles.

Electrochemical Cell FEM Analysis to Design and Optimize the Isoperibolic Calorimetric System for Laser Triggered Experiments

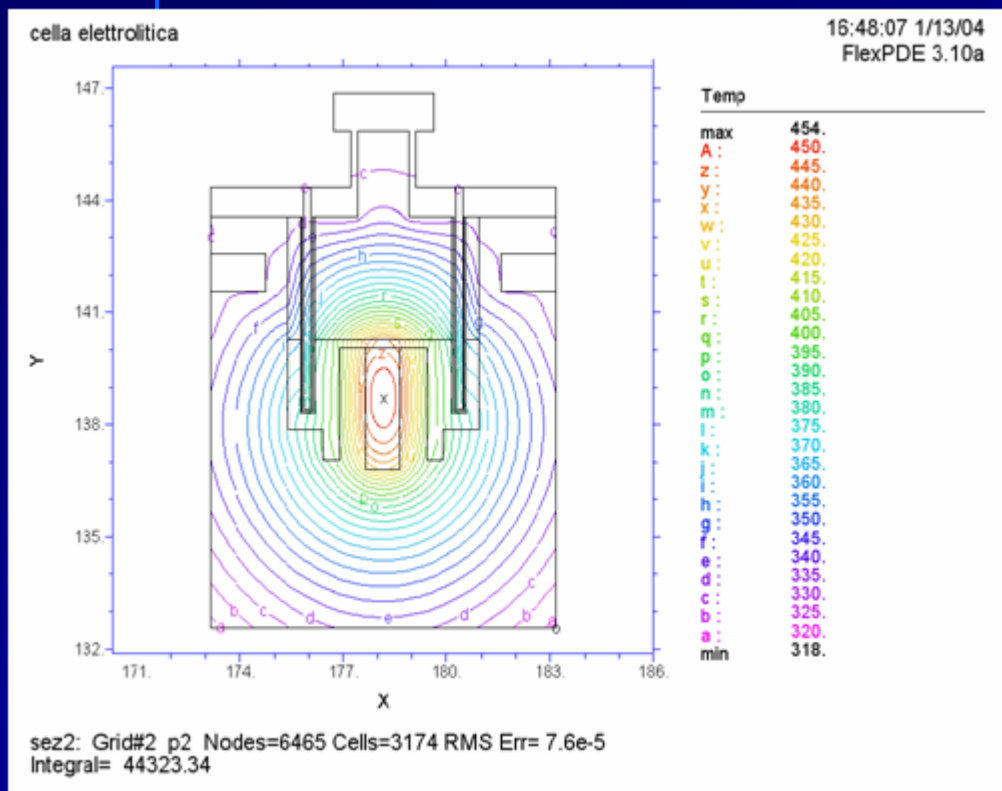

Simulated cell and experimental cell (closed cell with recombiner)

Isoperibolic Calorimetry for Laser Triggered Experiments.

Calibration is mandatory

Calibration based on the average of the 2 PT-100 temperature values obtained by means of electrolysis in LiOD.

Calibration 25-05-2004

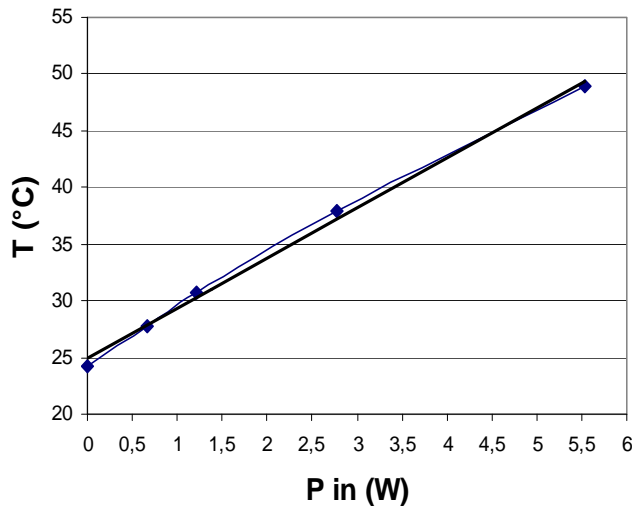

$$y = 4,4232x + 24,923$$
$$R^2 = 0,9968$$

Calibration 25-5-2004

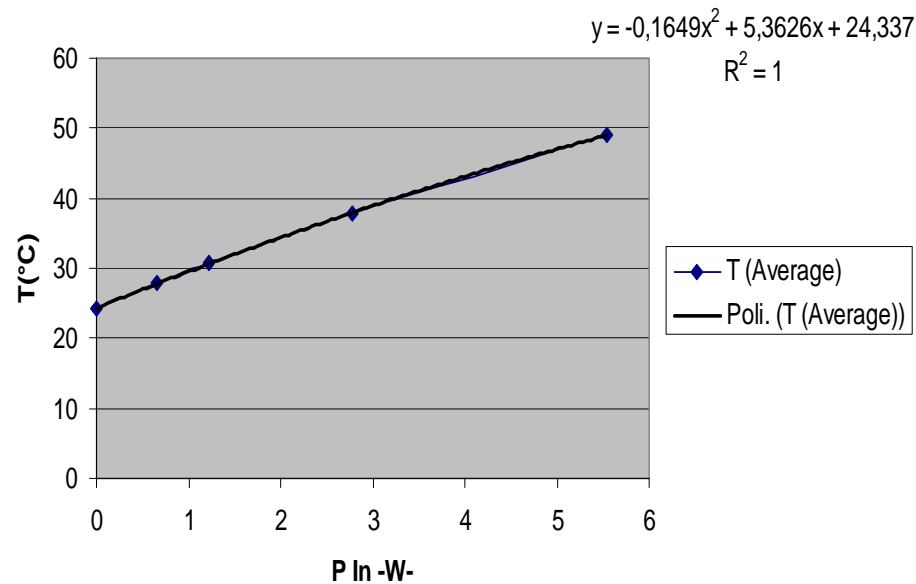

Calibration of the isoperibolic calorimeter

Laser2 Experiment

23.5 kJ of produced energy: 17.3 MJ/ mol Pd

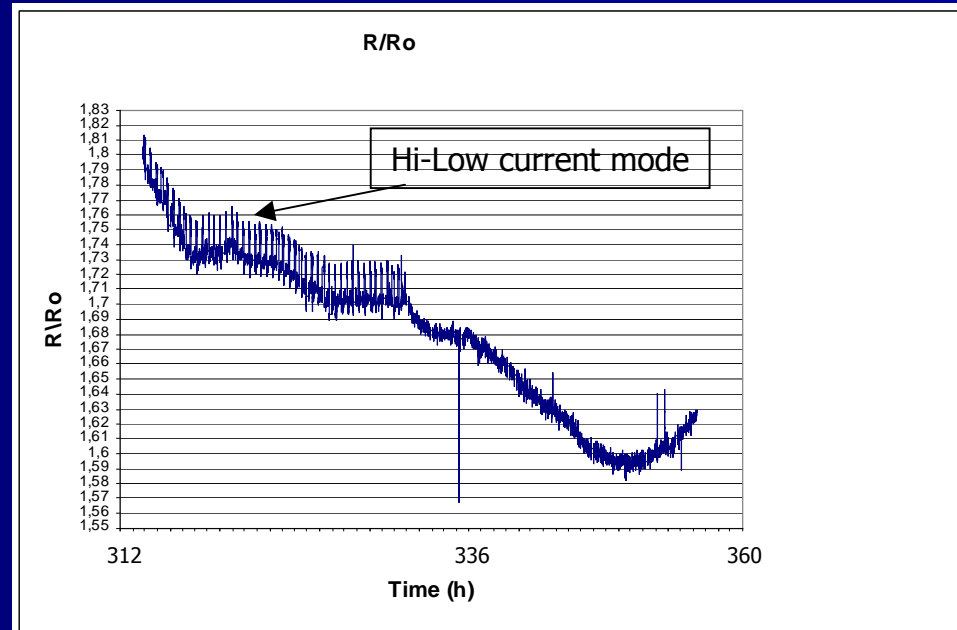
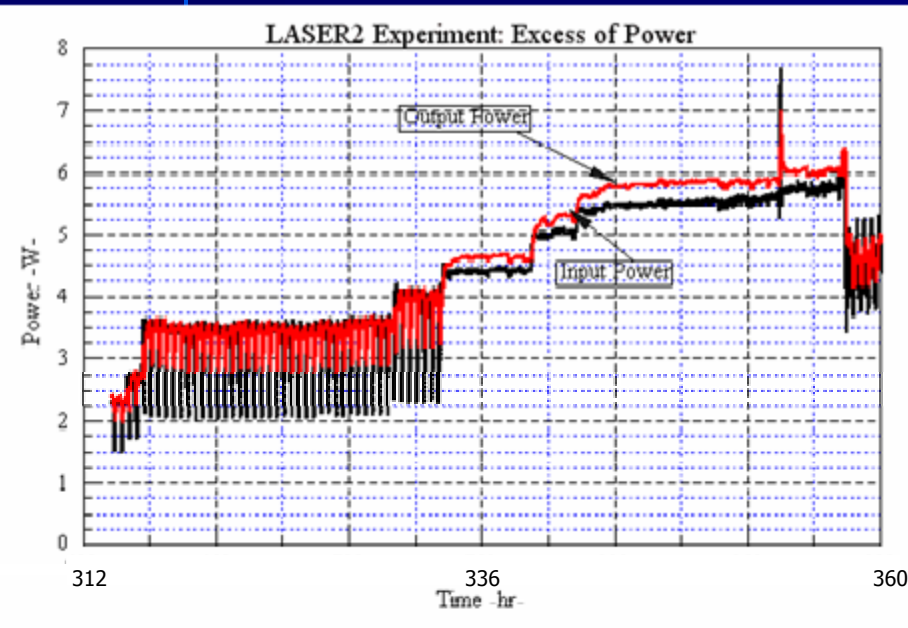

Evolution of the input and output power, last 300 hr under laser irradiation (P-polarization), 632 nm, 5 mW. ${}^4\text{He}$ production estimate $6.12\text{E}+15$.

Evolution of loading (normalized resistance).

Laser3 Experiment: Calorimetric Results

3.4 kJ of produced energy: 2.5 MJ/ mol Pd

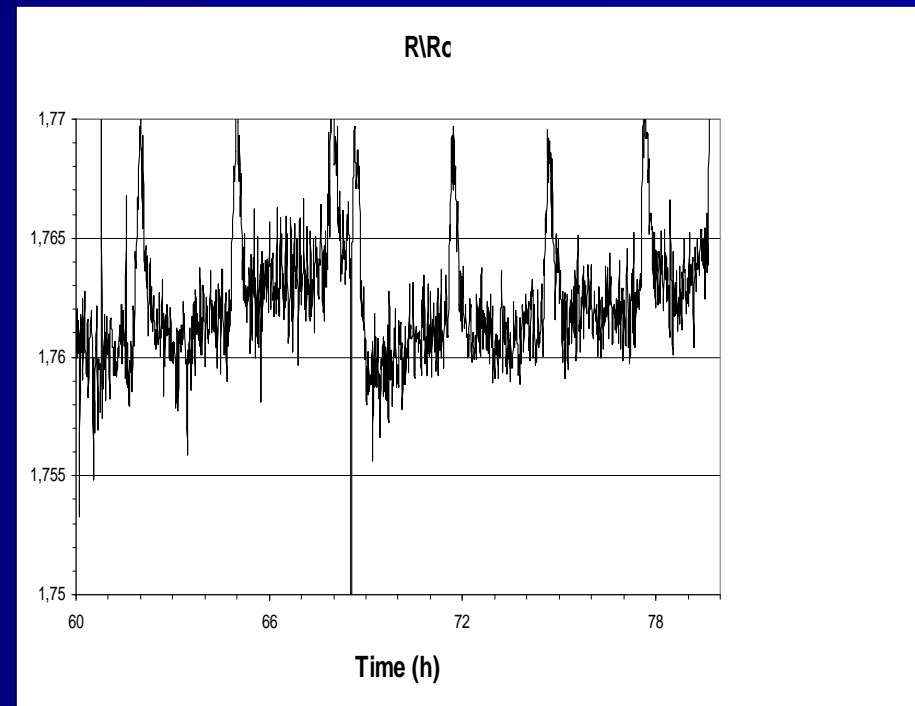
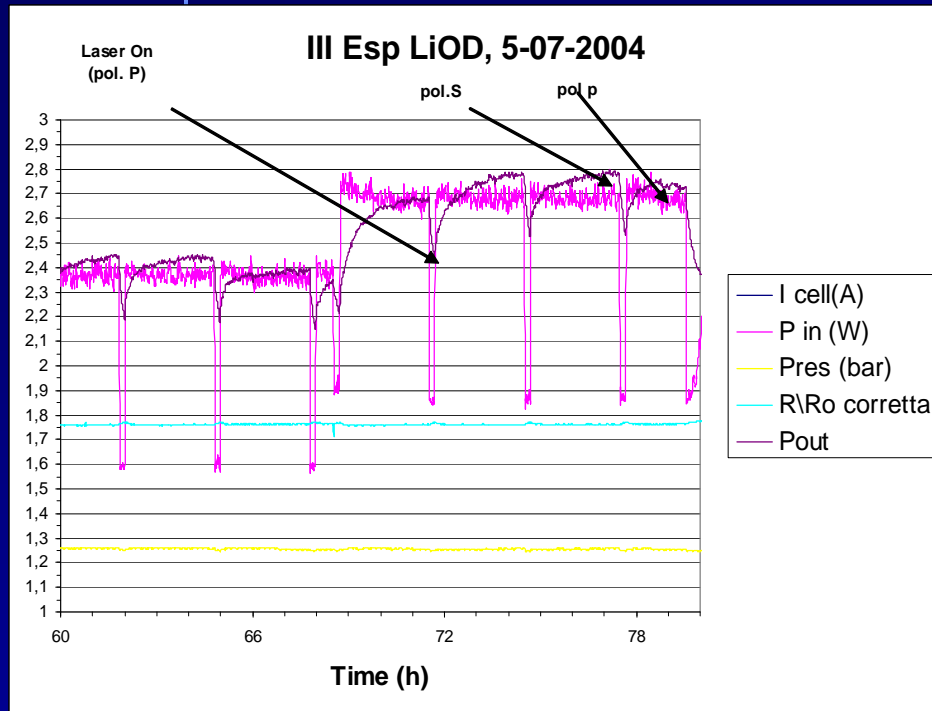

Excess of power under laser triggering (P and S polarization effect). 632 nm, 33 mW Hi-Lo current mode.

Loading evolution (normalized resistance)

Laser3 Experiment: Calorimetric Results

3.4 kJ of produced energy: 2.5 MJ/ mol Pd

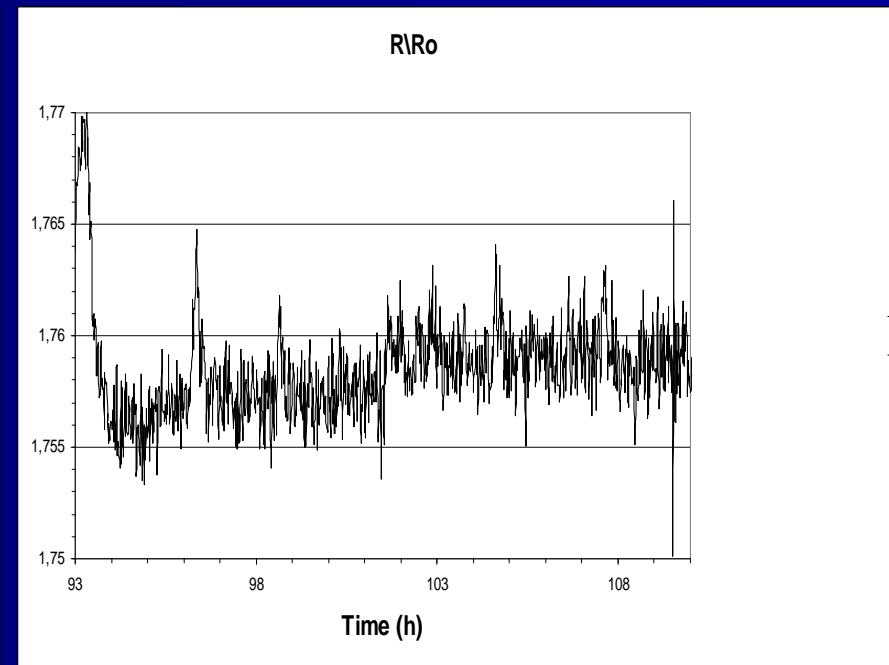
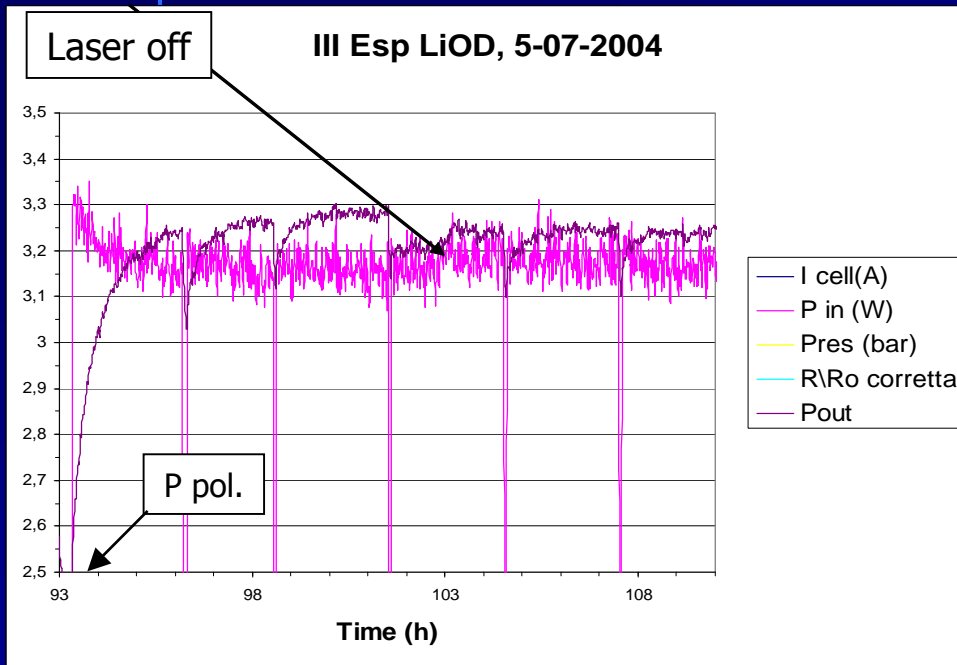

Excess of power under laser triggering (laser off effect). Hi-Lo current mode.

Loading evolution (normalized resistance)

Laser4 Experiment: Calorimetric Results

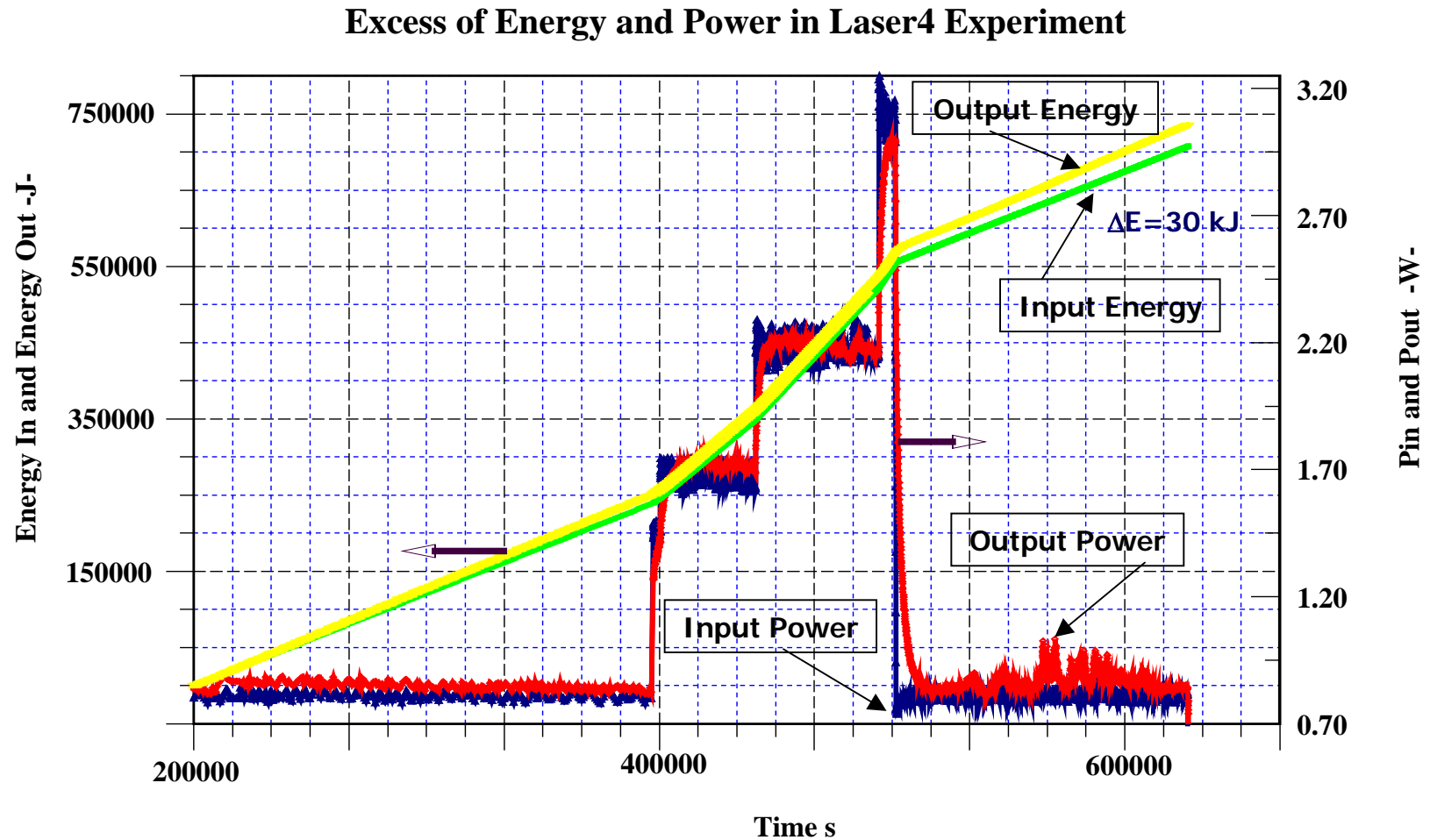

Excess of energy and excess of power in Laser4 experiment.

Laser4 Experiment: Calorimetric Results

30.3 kJ of produced energy: 19.4 MJ/ mol Pd

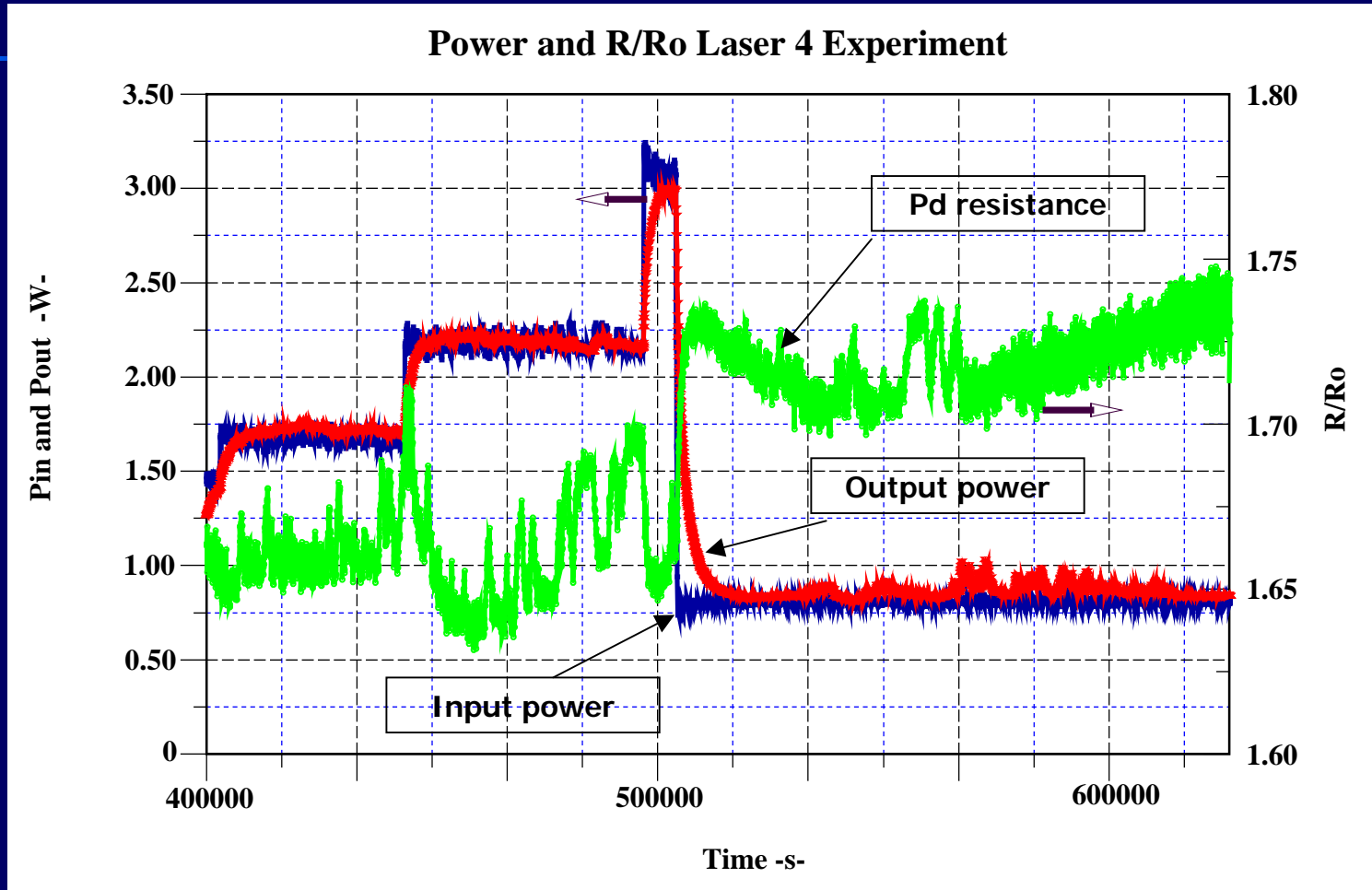

Excess of power and loading evolution.

Mass Spectrometer: JEOL GC Mate

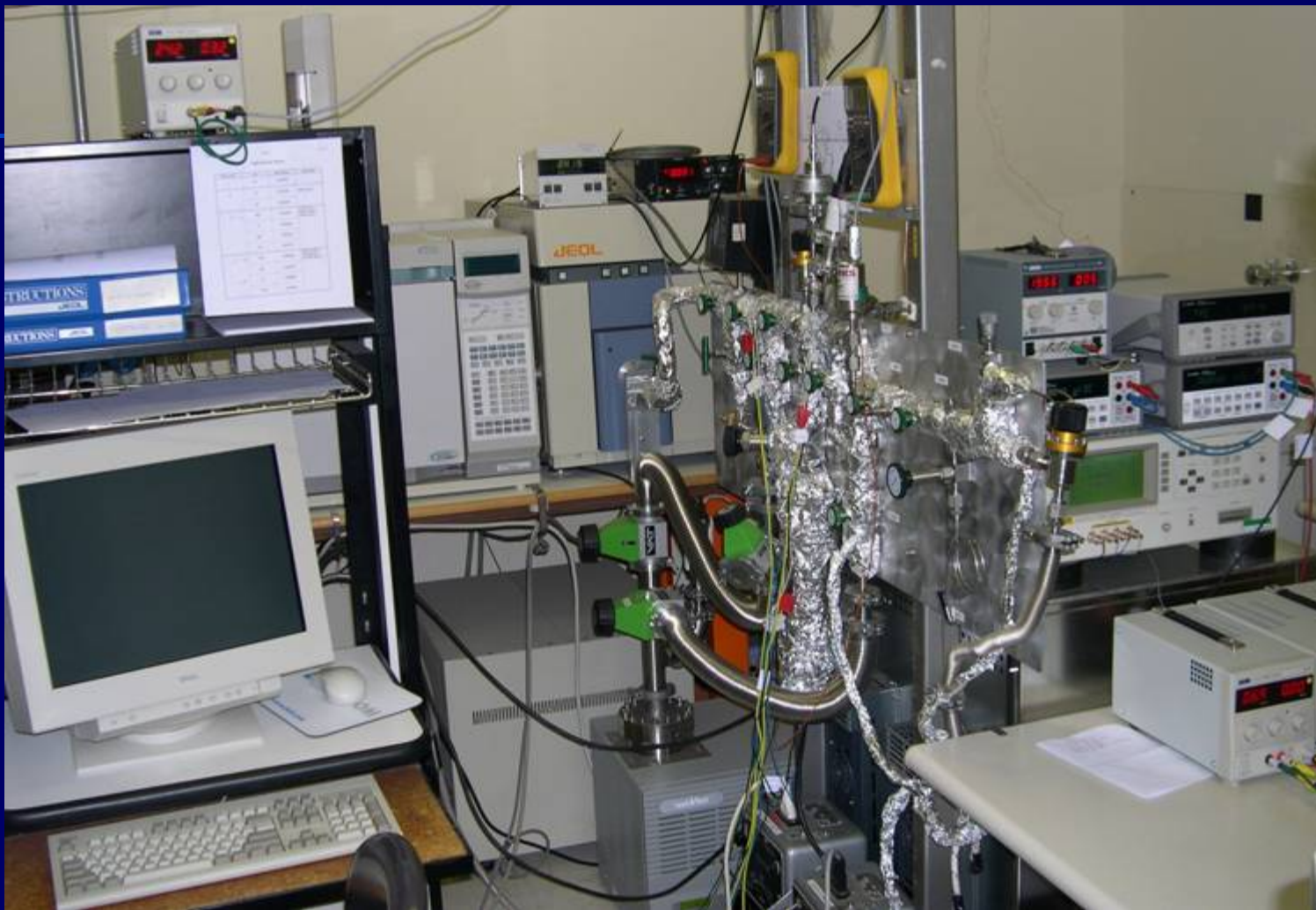

JEOL mass spectrometer and inlet system.

MS - Inlet Line

All VCR fitting, He leakage of the line $\leq 10^{-10}$ mbar l/s

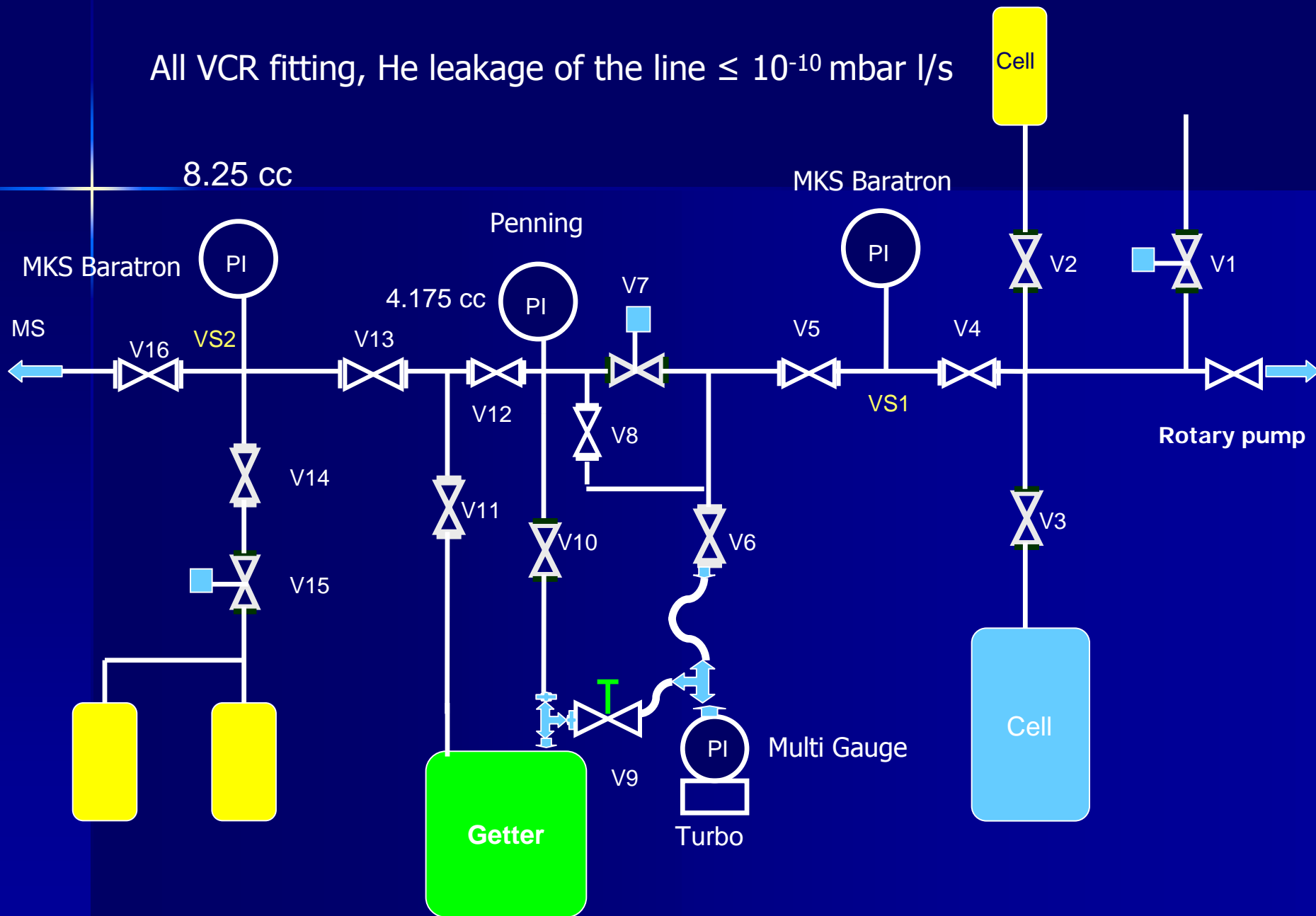

JEOL GC-Mate Resolution and Sensitivity

JEOL GC-MATE
Peak Profile for Mass 4

Sensitivity in SIM Mode is up to some fm-gr

$\Delta M = 0.0256$
AMU

He4

D2

Resolution = 150

JEOL GC-MATE
Peak Profile for Mass 2

2(10)
 $\Delta M = 0.00154$
AMU

D

H₂⁺

Peak Profile for Mass 3

$\Delta M = 0.00579$
AMU

3-He

HD

Resolution = 2100

27520ppm

GC-Mate resolution up to 0.0001 AMU, sensitivity in SIM mode up to some Fg.

Laser Triggered Experiments: ^4He Results

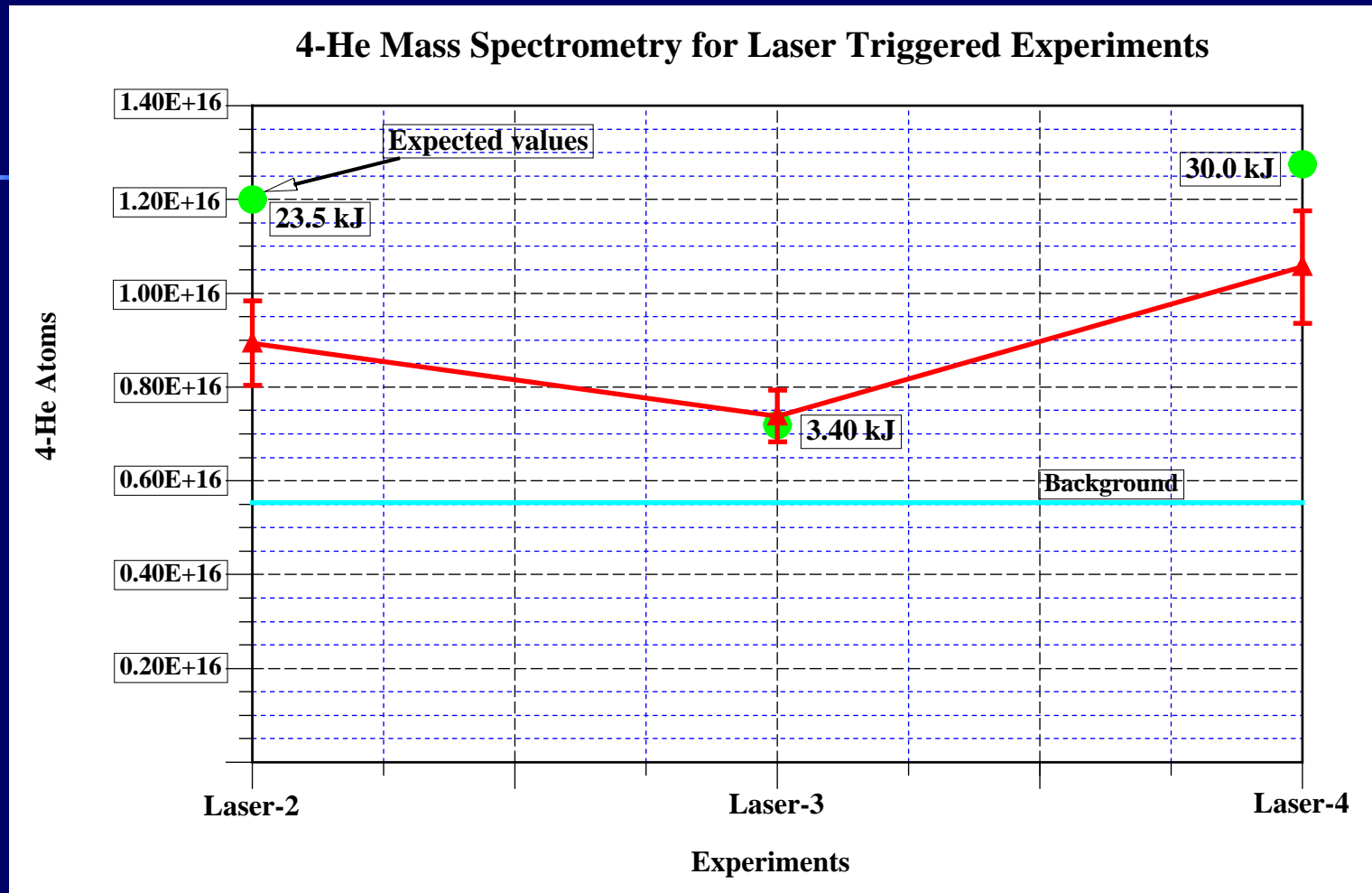

The expected amount of increasing of ^4He is in accordance with the energy gain by assuming a $\text{D}+\text{D} = ^4\text{He} + 24 \text{ MeV}$ reaction.

Conclusions

- Heat effects are observed with D, but not with H, under similar (or more severe) conditions.
- Heat bursts exhibit an integrated energy at least 10 x greater than the sum of all possible chemical reactions within a closed cell.
- Experiments reproducibility was significantly improved as a result of material science study.
- Conditions are required to have a reproducible excess of power:
 - 1) Loading threshold $D/Pd > 0.9$ (*necessary condition*).
 - 2) Suitable material to have a reproducible loading above the threshold.
 - 3) Trigger
 - 4) Suitable status of the material to have coupling with trigger.

Three excess of power over three effective experiments have been achieved by respecting these conditions!

The accordance between revealed ^4He and produced energy seems to be a clear signature of a nuclear process occurring in condensed matter.

Acknowledgments

The authors thank:

Energetis Technology for the support given to the development of these activities.

Sued Chemie for the help received in all the aspects of the research concerning the catalysts.

JEOL for the assistance in preparing the GC-Mate mass spectrometer.

File: L41610

Date Run: 10-16-2004

Time Run: 17:31:31

Sample: Analisi gas cella Laser-4 fine esperimento 16,10,04

Instrument: JEOL GCmate

Ionization mode: EI+

Run By: JEOL

Inlet: My Inlet

Printed by: JEOL

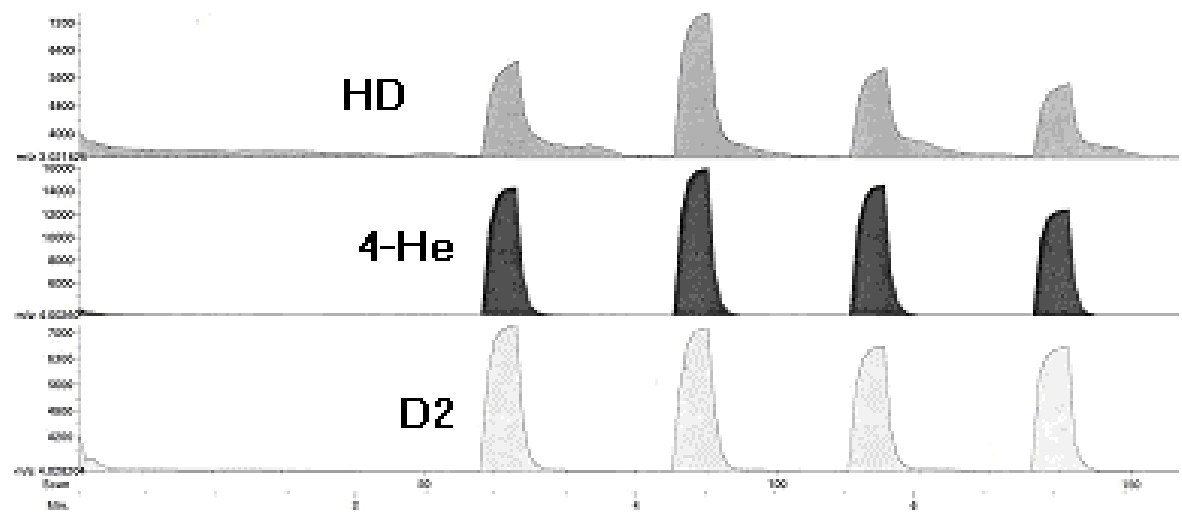

Different surface different behavior

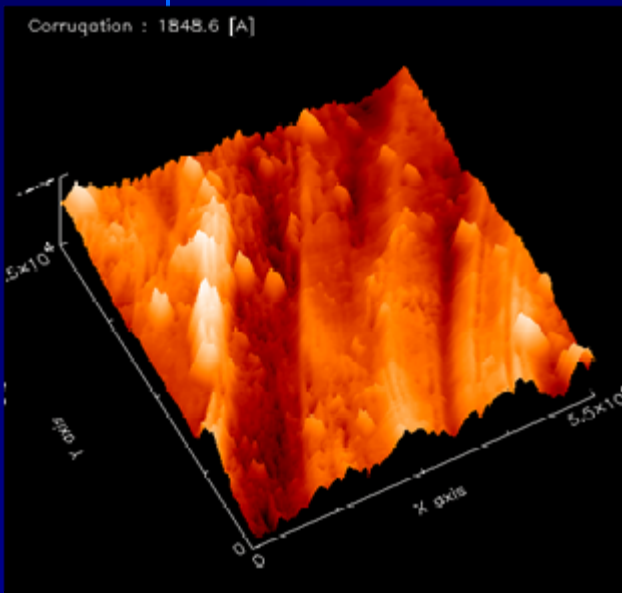

Palladium giving excess,
before electrolysis.

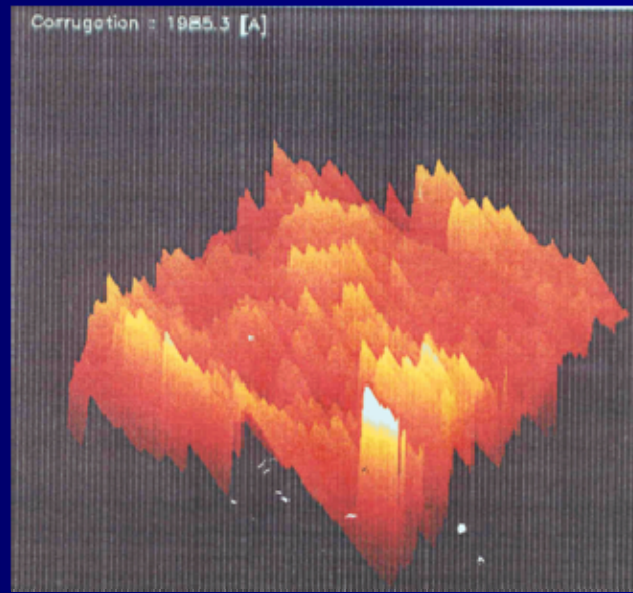

Palladium giving excess,
(after) with Pd deposition
during electrolysis.

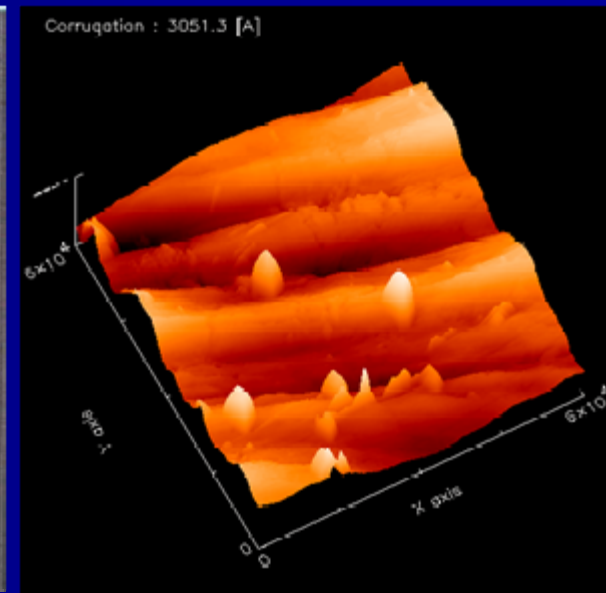

Not working palladium

Attention has been aroused in recent years by the anomalous enhancement of optical effects near metal/electrolyte interfaces, e.g., the Raman scattering of adsorbed molecules, second-harmonic surface generation, and photoemission from the surface [1, 2]. After analyzing the experiments most workers believe that two effects must be realized simultaneously to explain these phenomena, viz., so-called chemical amplification (which arises, in particular, from an increase in the transition moments owing to overlap of the electronic wave functions of the molecule with state functions of the metal adatoms [3]) and electrodynamic amplification owing to the formation of surface plasmons (SP; see [4] and the literature cited there). However, much remains unexplained in the phenomena being discussed. It is obscure, in particular, why for a significant enhancement of the optical processes occurring near the surface, the two effects mentioned must combine, and also why the enhancement is observed at distances up to hundreds of angstroms from the surface, even though the influence of chemical amplification should be limited to atomic distances. The strong dependence on a number of details of surface preparation also is difficult to explain.

In the present communication we offer an explanation for anomalous enhancement which is based on the idea that solitons to which the SP combine are generated on the metal surface. For its realization, this mechanism requires roughness, without which SP will not form or decay to light, and at the same time it requires effects of the type of chemical amplification, without which sufficiently strong nonlinearities in the field equations will not arise. Also needed is a special surface organization. For a quantitative estimate, we shall start from the following expression for the effect, S , of the electromagnetic field in the medium:

$$S = S_0 - iS_p \ln(1 + \Gamma G) = S_0 + iS_p \ln(1 - \Gamma G_0),$$
$$G = G_0 + G_0 \Gamma G, \quad \Gamma = -\frac{e}{2mc} (Ap + pA) + \frac{e^2}{2mc^2} A^2 + eq. \quad (1)$$

A. N. Frumkin Institute of Electrochemistry, Academy of Sciences of the USSR, Moscow.
Translated from *Elektrokhimiya*, Vol. 22, No. 2, pp. 270-273, February, 1986. Original
article submitted December 18, 1985.